

Electro-Mechanical Diaphragm Dosing Pumps User Manual



DosingPump.ir

Safety Precautions



Please read the entire manual carefully before installing and operating the device.



Device installation and maintenance must be done by trained personnel only.



Do not exceed the maximum working pressure indicated on the device.



Do not operate the device without using a pressure relief valve.



Before startup the device must be received air in the pump head and pipe.

1. Features

1.1 Description

Electro-Mechanical Diaphragm Metering Pumps move the diaphragm by helping circular motion that provided by electric motor, after it takes this motion convert it a linear motion with gear unit and camshaft. This movement can be changed with flow rate adjustment nut between 0% -100%. In this way, the pump can be adjusted according to user's needs.

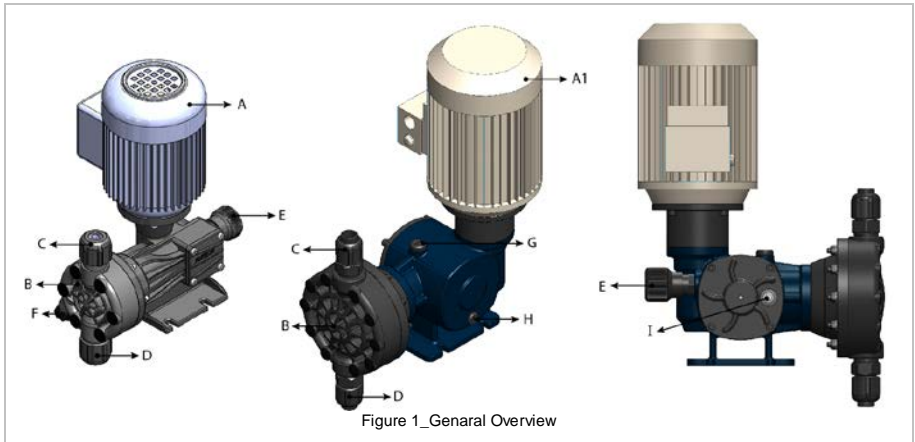

Figure 1_General Overview

A:	0,09 KW 3P Motor	E:	Flow Rate Adjustment Nut
A1:	0,25 KW 3P Motor	F:	Take Air Line Gland
B:	Pump Head	G:	Air Vent Stopper
C:	Injection Line Gland	H:	Oil Drain Stopper
D:	Suction Line Gland	I:	Oil Level Indicator

1.2 Flow Rate Adjustment

1. Manuel Flow Rate Adjustment:

It can be adjust with flow rate adjustment nut between 0% - 100% in linear while running or stopping.



2. Flow Rate Adjustment with 4-20mA Signal Input Motor Driver:

Please refer to that used motor driver wiring and connection diagrams

EMD-Dosing Pumps

1.2 EMD P Technical Specs

Stock Code	Model	L/h	Max. Counter Pressure Bar	Package Sizes/cm W-L-H	Packed Weight/Kg
311014005241(XXX)	EMD P14L/5B 380 (XXX)	14	5	31x38x23	5,90 (PCP)
311032005251(XXX)	EMD P32L/5B 380 (XXX)	32			5,95 (PSS)
311049005261(XXX)	EMD P49L/5B 380 (XXX)	49			7,40 (SSS)
311014005242(XXX)	EMD P14L/5B 220 (XXX)	14			6,00 (PVDFCP)
311032005252(XXX)	EMD P32L/5B 220 (XXX)	32			6,10 (PVCCP)
311049005262(XXX)	EMD P49L/5B 220 (XXX)	49			7,15 (PCP)
					7,20 (PSS)
					8,65 (SSS)
					7,25 (PVDFCP)
					7,35 (PVCCP)

EMD AUXILIARY EQUIPMENTS		
Stock code	Stock name	Description
410160011100001	EMD CONNECTION KIT 9X12 PP	SUCTION SET EMD 9X12 PP + INJECTION SET EMD 9X12 PP
410160012200001	EMD CONNECTION KIT 20MM PP	SUCTION SET EMD 20MM PP + INJECTION SET EMD 20MM PP
410160021100001	EMD CONNECTION KIT PVC 9X12MM	SUCTION SET EMD 9X12 PVC + INJECTION SET EMD 9X12 PVC
410160022200001	EMD CONNECTION KIT 20MM PVC	SUCTION SET EMD 20MM PVC + INJECTION SET EMD 20MM PVC
410170011100001	PIPE KIT 9X12 PE 10M	PIPE 9X12 PE 10 METERS

Electro-Mechanical Diaphragm Metering Pumps are manufactured in accordance to contact surfaces with chemicals and user requirements in the standards listed in the following table.

Pump selection is made by the user, accordance to application area or chemical type.

DosingPump.ir

Head Set Selection Standarts for Electromechanic Diaphragm Dosing Pumps(XXX)

CODE MODEL(XXX)	Pump	Ball	Ball	Diaphragm
000/PCP	PP / FRV	Ceramic	PTFE	PTFE / NBR
100/PSS	PP / FRV	S.S.316	S.S.316	PTFE / NBR
200/SSS	S.S.316	S.S.316	S.S.316	PTFE / NBR
300/PVDFCP	PVDF	Ceramic	PTFE	PTFE / NBR
400/PVCCP	PVC	Ceramic	PTFE	PTFE / NBR

Pump Model	Ø mm Diaphragm	Stroke/min.		capacity				Max. Pressure		Stroke mm	kW	Connections	Weight
		50Hz	60Hz	L1'		L/h		Bar	Psi				
				50Hz	60Hz	50Hz	60Hz						
EMD P14L/5B 380 (XXX)	66	42	50	0,23	0,28	14	17	5	72,5	4	0,09	3,8"	4,5 kg
EMD P32/5B 380 (XXX)		85	102	0,53	0,64	32	38						
EMD P49L/5B 380 (XXX)		128	153	0,82	0,98	49	59						

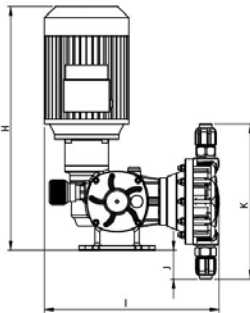
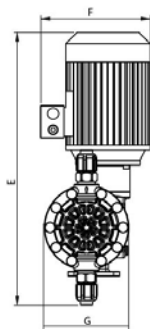
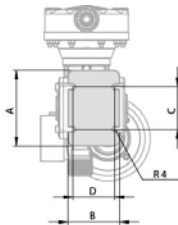

A:	125 mm
B:	85 mm
C:	70 mm
D:	69 mm
E:	448 mm
F:	180 mm
G:	139 mm
H:	400 mm
I:	287 mm
J:	47 mm
K:	255 mm

DosingPump.ir

EMD-Dosing Pumps

1.3 EMD M Technical Specs

Stock Code	Model	L/h	Max. Counter Pressure Bar	Package Sizes/cm W-L-H	Packed Weight/Kg
310034007001(XXX)	EMD M34L/7B 380 (XXX)	34	7	41 x 58 x 33	13,65 (PCP) 13,70 (PSS) 18,20 (SSS) 13,90(PVDFCP) 14,10 (PVCCP)
310050007101(XXX)	EMD M50L/7B 380 (XXX)	50			
310060007011(XXX)	EMD M60L/7B 380 (XXX)	60			
310075007021(XXX)	EMD M75L/7B 380 (XXX)	75			
310080007111(XXX)	EMD M80L/7B 380 (XXX)	80			
310100007121(XXX)	EMD M100L/7B 380 (XXX)	100			
310120007031(XXX)	EMD M120L/7B 380 (XXX)	120			
310150007131(XXX)	EMD M150L/7B 380 (XXX)	150			

EMD AUXILIARY EQUIPMENTS

Stock code	Stock code	Stock code
410160011100001	EMD CONNECTION KIT 9X12 PP	SUCTION SET EMD 9X12 PP + INJECTION SET EMD 9X12 PP
410160012200001	EMD CONNECTION KIT 20MM PP	SUCTION SET EMD 20MM PP + INJECTION SET EMD 20MM PP
410160021100001	EMD CONNECTION KIT PVC 9X12MM	SUCTION SET EMD 9X12 PVC + INJECTION SET EMD 9X12 PVC
410160022200001	EMD CONNECTION KIT 20MM PVC	SUCTION SET EMD 20MM PVC + INJECTION SET EMD 20MM PVC
410170011100001	PIPE KIT 9X12 PE 10M	PIPE 9X12 PE 10 METERS
600112610020000	EMD M 220 V KIT FOR EMD M	CONVERTER FROM 380 AC- 220 AC

Electro-Mechanical Diaphragm Metering Pumps are manufactured in accordance to contact surfaces with chemicals and user requirements in the standards listed in the following table.

Pump selection is made by the user, accordance to application area or chemical type.

DosingPump.ir

Head Set Selection Standarts for Electromechanic Diaphragm Dosing Pumps(XXX)				
CODE MODEL(XXX)	Pump	Ball	Ball	Diaphragm
000/PCP	PP / FRV	Ceramic	PTFE	PTFE / NBR
100/PSS	PP / FRV	S.S.316	S.S.316	PTFE / NBR
200/SSS	S.S.316	S.S.316	S.S.316	PTFE / NBR
300/PVDFCP	PVDF	Ceramic	PTFE	PTFE / NBR
400/PVCCP	PVC	Ceramic	PTFE	PTFE / NBR

Pump Model	Ø mm Diaphragm	Stroke/min.		capacity				Max. Pressure		Stroke mm	kW	Connections	Weight
		50Hz	60Hz	L1'		L/h		Bar	Psi				
				50Hz	60Hz	50Hz	60Hz						
EMD M34L/7B 380(XXX)	110	40	48	0,56	0,73	34	44	7	101,5	4	0,25	3,8"	11,5kg
EMD M60L/7B 380(XXX)		60	72	1	1,16	60	70						
EMD M70L/7B 380(XXX)		80	96	1,25	1,5	75	90						
EMD M120L/7B 380(XXX)		120	145	2	2,33	120	140						
EMD M50L/7B 380(XXX)		40	48	0,83	1	50	60						
EMD M80L/7B 380(XXX)		60	72	1,33	1,56	80	94						
EMD M100L/7B 380(XXX)		80	96	1,66	2	100	120						
EMD M150L/7B 380(XXX)		120	145	2,5	3	150	180						

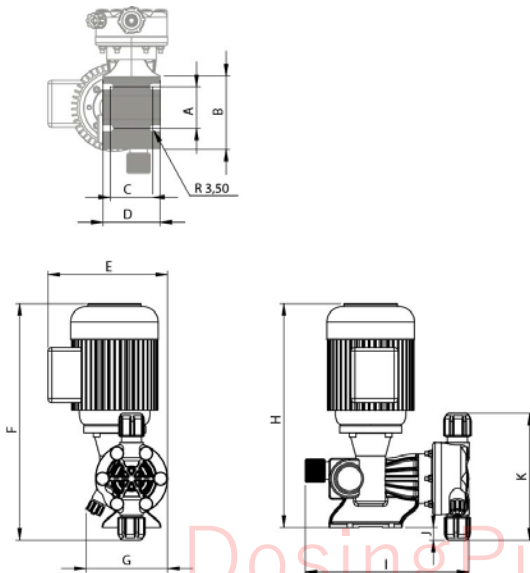

A:	53 mm
B:	93 mm
C:	54 mm
D:	73 mm
E:	152,5 mm
F:	300 mm
G:	104 mm
H:	285 mm
I:	209 mm
J:	16 mm
K:	161 mm



DosingPump.ir

2. Installation

2.1 Installation Instructions

- The environment where the device works should be well ventilated and dry. If it will be used outdoor, must be isolated from direct sunlight and water. And it is better to get it into a protective shelter.
- The temperature of the environment where the device runs, should not exceed 40°C. And the chemical temperature must be lower than 45°C.
- In order to get easier usage and better maintenance there must be at least 50 cm clearance around the device.
- In order to do proper installation provide a flat, durable and stainless metal surface.

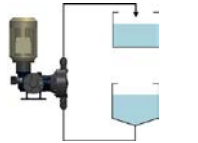
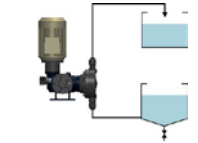
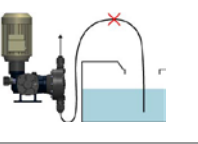
2.2 Connection Diagrams

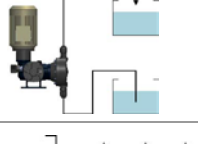
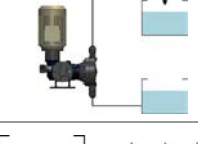
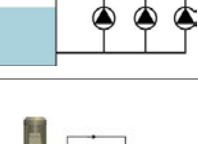
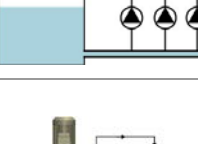
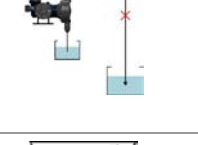
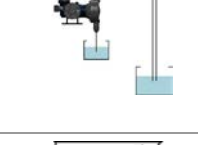
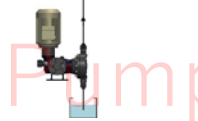
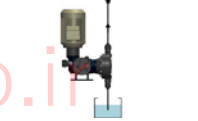
Decriptions	FALSE	TRUE
Device suction can be blockage from accumulate dirt and sediments in the bottom of the tank.		
Suction line connected pipe can be breakage from the highest point.		
It is due to an irregular suction. Device should be connect most nearby distance		
The diameters of suction manifold of the pumps that are connected as parallel, must suitable according to total flow rate of the pumps.		
To a warehouse where located in the lower levels of the chemical tanks cannot be made directly a dosing. With siphon effect Chemical is drained to other tank.		
Without using injection line tool, there must not be direct chemical dosing to the line that has pressure.		

2.3 Pressure Discharge Valve Usage

A pressure discharge valve is required between dosing line and pump over injection line for Electro-Mechanical Diaphragm Metering Pump.

Pressure discharge valve protects your pump from extreme and sudden rise in pressure. Also protects from high pressure may occur due to congestion on the discharge line.

Pressure discharge valve connection is made as shown in the adjacent figure.

Pressure discharge valve setting, must not exceed the maximum pressure value of the pump.

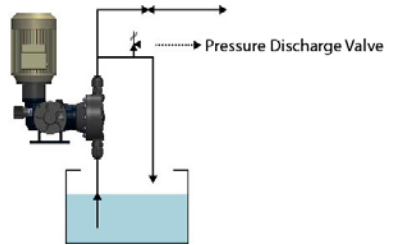

2.4 General Installation

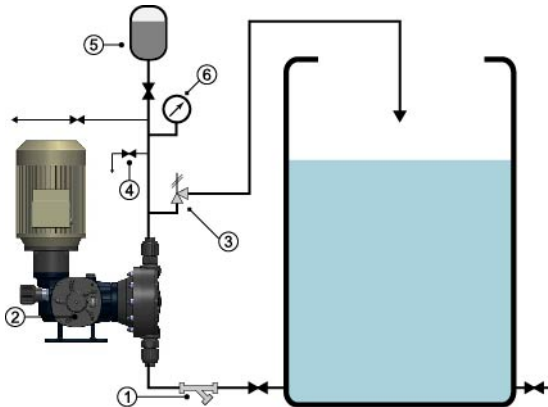

1. "Y" Filter
2. EMD Dosing Pump
3. Pressure Discharge Valve
4. Drain Valve
5. Pressure Compensating (Dampener)
6. Pressure Indicator

2.5 For Oil Filling

For EMD-M models oil must be checked from oil indicator with regular intervals. If the oil is below the desired level, oil supplementation is made. (please refer to oil filling Figure_1 G, H and I) In each 2000 hours work and 6 months period of pump oil should be replaced with the new one.

Using Suggested Oils

Brand	Type
ESSO	SPARTAN EP 320
MOBIL	MOBILGEAR 632
SHELL	OMALA OIL 320

Dosing Pump.ir

EMD-Dosing Pumps

3. Usage



Please observe the following precautions before operating your device!

- Check the oil from the oil level indicator before running the EMD M models. Add the oil below the desired level.
- Please check the electric connections and motor rotation way. motor rotation way must be the same direction as the arrow shown on the pump.
- Please check the valves positions on the system. If the valves is closed please turn on.
- Please check the pump head group, suction - injection line groups and all pipes are suitable (should not any leak or blockage)
- In first use please run the device in %20 performance at 3-5 minutes. After that process turn on to gradual for max capacity. Then adjust the desired flow rate setpoint.
- Check the system pressure. System pressure must be lower than the device working pressure. If it is not suitable. Please don't use the pump.

4. Maintenance



All parts placements must be same with the figure below.

EMD-M Pump Head Group

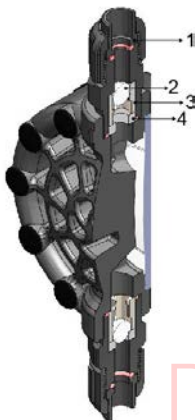

- 1.Hose End 3/8
- 2.Ceramic Ball
- 3.Ball Housing 5
- 4.Ball Housing 5 Adapter

EMD-P Pump Head Group

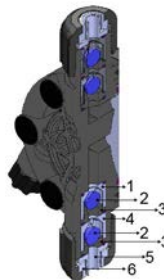

- 1.Ball Housing 4A
- 2.Ceramic Ball
- 3.Ball Housing 4A Adapter
- 4.Ball Housing 4B
- 5.8x12 Hose End
- 6.8x12 Hose Pressure Plate

DosingPump.ir

DosingPump.ir

