

DLX - DLXB VFT/MBB



www.etatronds.com

 **ETATRON D.S.**

IT NORME DI INSTALLAZIONE, USO E MANUTENZIONE

UK OPERATING INSTRUCTIONS AND MAINTENANCE

DosingPump.ir

CE  
UNI EN ISO 9001-2008

(IT) DIRETTIVA "RAEE" 2002/96/CE E SUCCESSIVA MODIFICA 2003/108/CE SUI RIFIUTI DI APPARECCHIATURE ELETTRICHE ED ELETTRONICHE

Il simbolo sotto riportato indica che il prodotto non può essere smaltito come normale rifiuto urbano.

Le Apparecchiature Elettriche ed Elettroniche (AEE) possono contenere materiali nocivi per l'ambiente e la salute e pertanto devono essere oggetto di raccolta differenziata: smaltite quindi presso apposite discariche o riconsegnate al distributore a fronte dell'acquisto di una nuova, di tipo equivalente o facente le stesse funzioni.

La normativa sopracitata, alla quale rimandiamo per ulteriori particolari e approfondimenti, prevede sanzioni per lo smaltimento abusivo di detti rifiuti.

(UK) WASTE OF ELECTRICAL AND ELECTRONIC EQUIPMENT DIRECTIVE (WEEE, RAEE in Italy) 2002/96/EC AND SUBSEQUENT AMENDMENT 2003/108/EC

The marking shown below indicates that the product cannot be disposed of as part of normal household waste.

Electrical and Electronic Equipment (EEE) can contain materials harmful to health and the environment, and therefore is subject to separate waste collection: it must be disposed of at appropriate waste collection points or returned to the distributor against purchase of new equipment of similar type or having the same functions.

The directive mentioned above, to which make reference for further details, provides for punitive actions in case of illegal disposal of such waste.



INDEX

1.0 - HINTS AND WARNING	pag. 14
1.1 - WARNING	14
1.2 - SHIPPING AND TRANSPORTING THE PUMP	14
1.3 - PROPER USE OF THE PUMP	14
1.4 - RISKS	14
1.5 - TOXIC AND/OR DANGEROUS LIQUID DOSAGE	15
1.6 - ASSEMBLING AND DISMANTLING THE PUMP	15
2.0 - DLX & DLX/B SERIES METERING PUMPS	16
2.1 - OPERATION	16
2.2 - TECHNICAL SPECIFICATIONS	16
2.3 - LIQUID ENDS MATERIALS	17
3.0 - INSTALLATION	18
3.1 - INJECTION VALVE INSTALLATION DIAGRAM	19
3.2 - MANUAL STROKE LENGTH ADJUSTMENT	19
3.3 - WIRING CONNECTION AND OUTPUT CONNECTOR FUNCTIONS	20
4.0 - MAINTENANCE	21
5.0 - HOW TO OPERATE WHEN DOSING SULPHURIC ACID	21
6.0 - DLX & DLX/B VFT/MBB MICROCONTROLLER DOSING PUMPS	22
6.1 - PUMP CONTROLS	22
6.2 - TYPICAL INSTALLATION	22
6.3 - ACCESSORIES	22
6.4 - LEVEL CONTROL	22
7.0 - VFT/MBB FEATURE DESCRIPTION	23
8.0 - INPUT/OUTPUT EXTERNAL CONNECTIONS (FOR EXTERNAL ACCESSORY)	24
9.0 - TROUBLE SHOOTING COMMON TO DLX & DLX/B SERIES PUMP	24
9.1 - MECHANICAL FAULTS	24
9.2 - ELECTRICAL FAULTS	24
EXPLODED VIEWS	25-28

1.0 - HINTS AND WARNINGS

Please read the warning notices given in this section very carefully, because they provide important information regarding safety in installation, use and maintenance of the pump.

- Keep this manual in a safe place, so that it will always be available for further consultation.
- The pump complies with EEC directives No.89/336 regarding "electromagnetic compatibility" and No.73/23 regarding "low voltages", as also the subsequent modification No.93/68.

N.B. The pump has been constructed in accordance with best practice. Both its life and its electrical and mechanical reliability will be enhanced if it is correctly used and subjected to regular maintenance.

1.1 - WARNING:

Any intervention or repair to the internal parts of the pump must be carried out by qualified and authorized personnel. The manufacturers decline all responsibility for the consequences of failure to respect this rule.

GUARANTEE: 1 year (the normal wearing parts are excluded, i.e.: valves, nipples, tube nuts, tubing, filter and injection valve). Improper use of the equipment invalidates the above guarantee. The guarantee is ex-factory or authorized distributors.

1.2 - SHIPPING AND TRANSPORTING THE PUMP

The pump should always be moved in a vertical (and never in a horizontal) position. No matter what the means of transport employed, delivery of the pump, even when free to the purchaser's or the addressee's domicile, is always at the purchaser's risk. Claims for any missing materials must be made within 10 (ten) days of arrival, while claims for defective materials will be considered up to the 30th (thirtieth) day following receipt. Return of pumps or other materials to us or the authorized distributor must be agreed beforehand with the responsible personnel.

1.3 - PROPER USE OF THE PUMP

- The pump should be used only for the purpose for which it has been expressly designed, namely the dosing of liquid additives. Any different use is to be considered improper and therefore dangerous. The pump should not therefore be used for applications that were not allowed for in its design. In case of doubt, please contact our offices for further information about the characteristics of the pump and its proper use. The manufacturers cannot be held responsible for damage deriving from improper, erroneous or unreasonable use of the pump.

1.4 - RISKS

- After unpacking the pump, make sure it is completely sound. In case of doubt, do not use the pump and contact qualified personnel. The packing materials (especially bags made of plastics, polystyrene, etc.) should be kept out of the reach of children: they constitute potential sources of danger.
- Before you connect the pump, make sure that the voltage ratings, etc., correspond to your particular power supply. You will find these values on the rating plate attached to the pump.
- The electrical installation to which the pump is connected must comply with the standards and good practice rule in force in the country under consideration.
- Use of electrical equipment always implies observance of some basic rules: In particular:
 - 1 - do not touch the equipment with wet or damp hands or feet;
 - 2 - do not operate the pump with bare feet (Example: swimming pool equipment);
 - 3 - do not leave the equipment exposed to the action of the atmospheric agents;
 - 4 - do not allow the pump to be used by children or unskilled individuals without supervision;
- In case of breakdown or improper functioning of the pump, switch off, but do not touch. Contact our technical assistance for any necessary repairs and insist on the use of original spares. Failure to respect this condition could render the pump unsafe for use.
- When you decide to make no further use of an installed pump, make sure to disconnect it from the power supply.

Before carrying out any service on the item, check:

1. **Disconnect the pins from the mains or by means of a two poles switch with 3 mm minimum distance between the contacts. (Fig. 4).**
2. **Relieve all the pressure from the pump head and injection tube.**
3. **Drain or flush all dosing liquid from the pump head. This operation can also be done with the pump disconnected from the plant by turning the pump upside-down for 15 to 30 seconds and without connecting the tubing to the nipples: if this operation is not possible, dismount and remount the pump head using the four mounting screws.**

In event of possible losses in the hydraulic system of the pump (breakage of the "O" ring gasket, the valves or the hoses) the pump should immediately be brought to a stop, emptying and depressurizing the delivery hose while taking all due safety precautions (gloves, goggles, overalls, etc.).

1.5 - TOXIC AND/OR DANGEROUS LIQUID DOSAGE

To avoid risk from contact with the hazardous liquids or toxic fumes, always adhere to the notes in this instruction manual:

- Follow the instructions of the dosing liquid manufacturer.
- Check the hydraulic part of the pump and use it only if it is in perfect condition.
- Use only the correct materials for the tubing, valves and seals to suit the liquid to be dosed; where possible shield the tubing with PVC conduit.
- Before disconnecting the metering pump, make sure to flush out and neutralize the pump head with the proper reagent liquid.

1.6 - ASSEMBLING AND DISMANTLING THE PUMP

1.6.1 - ASSEMBLY

All metering pumps are normally supplied fully assembled. For greater clarity, please consult the exploded view of the pump appended at the end of the manual, which shows all the pump details and a complete overview of all the pump components. These drawings are in any case quite indispensable whenever defective parts have to be re-ordered. For the same purpose, the appendix also contains other drawings showing the hydraulic parts (pump head and valves).

1.6.2 - DISMANTLEMENT

Proceed as follows before you dismantle the pump or before performing any other operation on it:

1. Disconnect the pins from the mains or by means of a two poles switch with 3 mm minimum distance between the contacts. (Fig. 4).
2. Relieve all the pressure from the pump head and injection tube.
3. Drain or flush all dosing liquid from the pump head. This operation can also be done with the pump disconnected from the plant by turning the pump upside-down for 15 to 30 seconds and without connecting the tubing to the nipples: if this operation is not possible, dismount and remount the pump head using the four mounting screws. (Fig. 12)

This operation calls for special attention, and you should therefore consult the drawings in Appendix and Chapter 1.4 "RISKS" before you commence work.

OVERALL DIMENSIONS (Fig. 1)

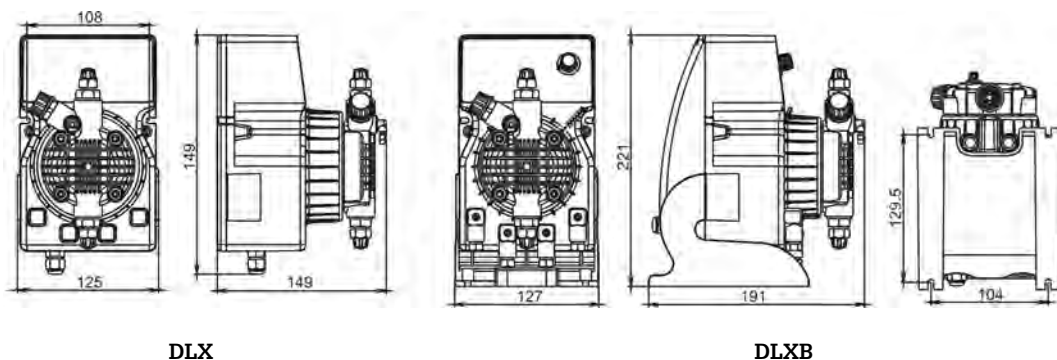

2.0 - DLX AND DLX/B SERIES METERING PUMPS

2.1 - OPERATION

The metering pump is activated by a teflon diaphragm mounted on a piston of an electromagnet. When the piston of the electromagnet is attracted, a pressure is produced in the pump body with an expulsion of liquid from the discharge valve. Once the electric impulse is finished a spring brings the piston back to the initial position, with a recall of liquid through the suction valve. The operation is simple the pump does not need lubrication, therefore maintenance is reduced almost to zero. The materials used for the construction of the pump make it particularly suitable for aggressive liquids. The metering pump has been designed to feed liquids with capacities from 0 to 20 l/h and pressures from 0 to 15 bar (depending on the model selected).

2.2 - TECHNICAL SPECIFICATIONS

- The products are manufactured according **CE** regulation.
- Environmental Conditions: IP 65 protection, altitude up to 2000m, ambient temperature 5°C to 40°C, maximum relative humidity 80% for temperatures up to 31°C decreasing linearly to 50% relative humidity at 40°C.
- Pollution degree 2
- Overvoltage cat. II
- Antiacid plastic casing.
- Control panel protection assured by an adhesive polyester film, weatherproof and resisting UV ray
- Standard power supply (fluctuations not to exceed $\pm 10\%$):
230 V a.c. 50 Hz single phase.
- Optional power supply (fluctuations not to exceed $\pm 10\%$):
240 V a.c. 50-60 Hz single phase;
110 V a.c. 50-60 Hz single phase.
- Connections for level probe, flow sensor, water meter and relè output (activated by flow alarm (AL2) and too many pulses alarm (AL3)).
- Upon request: manual stroke length adjustment. This control provides accurate flow adjustment. (only DLXB series)

Operating functions:

- Manual** The pump can be programmed to operate manually from 0 to 100% of flow.
- 1xN** When a pulse generating water meter is connected to the pump, every pulse received will cause the pump to pulse N times. Operating range: 0-999 pulses for each contact
- 1xN(M)** Every pulse from a water meter will cause the pump to pulse N times. While the pump is pulsing, it still registers all further signals received (M) and translates them into successive pulses. Operating range: 0 – 999 pump pulses (value of N) for each signal received

1 : N

When a water meter is connected to the pump, every N number of signals received from the water meter will cause the pump to pulse once.

OUTPUT SERVICE RELAY

This relay will be closed when an excessive amount of pulses will be present or flow will arrive.

Characteristic: 1 pole - 250V a.c. 5A (resistive load)

2.3 - LIQUID ENDS MATERIALS

DIAPHRAGM: PTFE

PUMP HEAD: Polypropylene; upon request: PVC, 316 Stainless, PTFE

NIPPLES: polypropylene

FILTER: polypropylene

INJECTION NIPPLE: polypropylene

SUCTION HOSE: PVC - flexible

DISCHARGE HOSE: polyethylene

VALVES "lip" type: FPM (viton), (upon request available in EPDM (Dutral), NBR, Silycon). "Ball Check" VALVES upon request type in SS 316 and Glass PYREX. Available with Spring Return and "KALRETZ" Valve.

SEALS: FPM upon request EPDM (Dutral), NBR, Silycon, PTFE only for ball checks valves

MAIN FEATURES

Tipo Type	Portata max Max flow l/h	Pressione max Max press bar	Max imp./min. Max imp./min.	Dosaggio per imp. Output per stroke ml	Corsa Stroke mm	Altez. aspiraz. Suction height m	Aliment. elettr. standard Standard power supply Volts - Hz	Potenza ass. Power comp. Watts	Corrente ass. Current comp. Ampere	Peso netto Net weight kg
1-15	1	15	120	0.14	0.80	2.0	230 V 50-60 Hz	37	0.16	2.3
2-10	2	10	120	0.28	0.80	2.0	230 V 50-60 Hz	37	0.16	2.3
5-7	5	7	120	0.69	1.00	2.0	230 V 50-60 Hz	37	0.16	2.3
5-12	5	12	120	0.69	1.00	2.0	230 V 50-60 Hz	58	0.25	2.9
8-10	8	10	120	1.11	1.40	2.0	230 V 50-60 Hz	58	0.25	2.9
15-4	15	4	120	2.08	2.20	2.0	230 V 50-60 Hz	58	0.25	2.9
20-3	20	3	120	2.60	2.20	2.0	230 V 50-60 Hz	58	0.25	2.9
2-20	2	20	120	0.28	1.00	2.0	230 V 50-60 Hz	58	0.25	2.9

Fig. 2

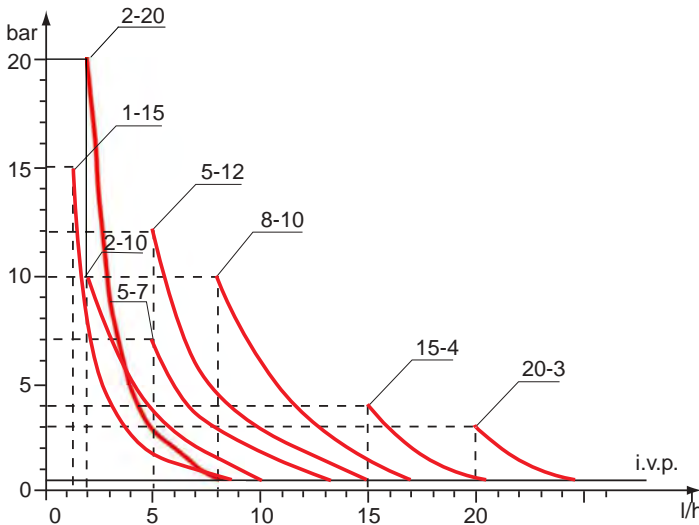

Fig. 3

The diagrams of fig. 3 indicate max metering pump flow variation in relation to the working pressure in the plant; the diagrams also include injection valve losses. I.V.P.

Due to production requirements the technical characteristics of our equipment at maximum ratings can vary with a tolerance of 5% which must be taken into account when choosing the type of pump.

3.0 - INSTALLATION

- a. - Install the pump in a dry place and well away from sources of heat and, in any case, at environmental temperatures not exceeding 40°C. The minimum operating temperature depends on the liquid to be pumped, bearing in mind that it must always remain in a liquid state.
- b. - Carefully observe the regulations in force in the various countries as regards electrical installations (Fig.4). **When the supply cable is devoid of a plug, the equipment should be connected to the supply mains by means of a single-pole circuit breaker having a minimum distance of 3 mm between the contacts. Before accessing any of the electrical parts, make sure that all the supply circuits are open.**

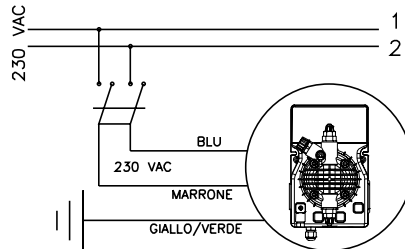

Fig. 4

- c.- Locate the pump as shown in fig. 5 bearing in mind that it may be installed either below or above the level of the liquid to be dosed, though the level difference should not exceed 2 meters. When the process plant in which the pump is installed is operating at atmospheric pressure (no back pressure) and the chemical tank is situated above the plant (Fig. 6), the condition of the injection valve should be checked at regular intervals, because excessive wear and tear could cause additive to drip into the plant even when the pump is shut down. If the problem persists, install a properly calibrate counter-pressure valve (C) between injection point and the valve. In the case of liquids that generate aggressive vapours, do not install the pump above the storage tank unless the latter is hermetically sealed.

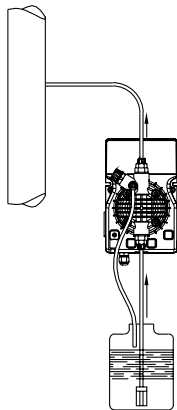

Fig. 5

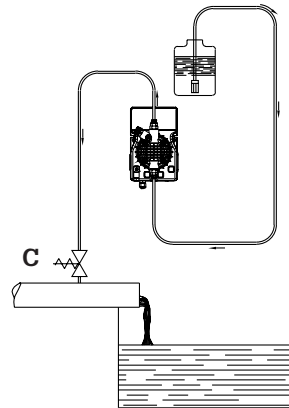

Fig. 6

- d.- The discharge nipple will always remain in the upper part of the pump. The suction nipple, which serves to attach the hose (with filter) leading into the chemical tank, will therefore always be situated in the lower part of the pump.

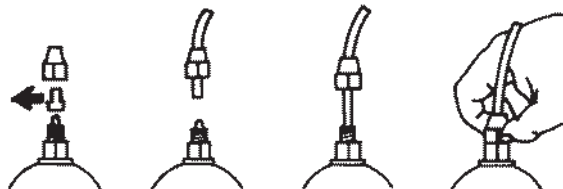

Fig. 7

- e.- Remove the protection caps from the two nipples, slide the hoses over the connectors, pushing them right home, and then fix them with appropriate tube nuts. (Fig. 7).

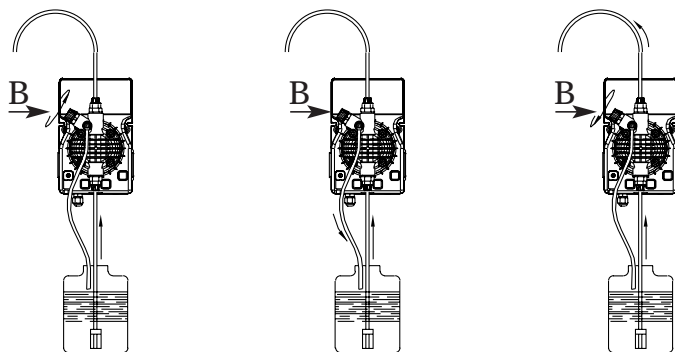

Fig. 8

Whenever the pump is dismantled from the pipework, you will be well advised to replace the caps on the connectors to avoid residual liquid being spilled. Before attaching the delivery hose to the plant, prime the metering pump by going through the sequence shown in Fig. 8. Before finalizing the installation of the discharge hose, make sure that the pump strokes will not cause it to move and bump into rigid bodies. In case of priming difficulties, use a normal syringe to suck liquid from the discharge nipple while the pump is in operation, continuing until you actually see the liquid rise in the syringe. Use a short length of suction hose to connect the syringe to the discharge nipple. In case of a pump equipped with an air bleed valve, unscrew the air relief valve B up to all the air in the pump head will be out.

- f. - Try to keep both the suction and discharge hose as straight as possible, avoiding all unnecessary bends.
 - g. - Select the most appropriate injection point on a pipe of the plant to be treated and there fit a 3/8" female steel gas thread connector (similar to BSPm). This connector is not supplied with the pump. Screw the injection valve to the gas connector, inserting a gasket as shown in Fig. 9. Then connect the discharge hose to the conical connector on the injection valve and fix it with the supplied tube nut G. The injection valve also acts as no return valve by means of a cylinder sleeve (elastomer, standard supplied in Viton).
- N.B. The sleeve D must not be removed.**

3.1 - INJECTION VALVE INSTALLATION

DIAGRAM Fig. 9

- A - Pipework
- C - Injection valve
- M - Conical connector for attaching the discharge hose
- N - 3/8" female steel gas thread connector
- G - Hose tube nut
- T - Polyethylene hose
- D - Cylinder sleeve (no return valve)

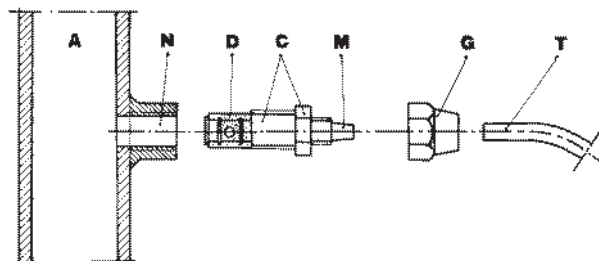

3.2 - MANUAL STROKE LENGTH ADJUSTMENT - (upon request only for DLXB)

- press and turn the knob (1) up to the stroke length adjustment required.

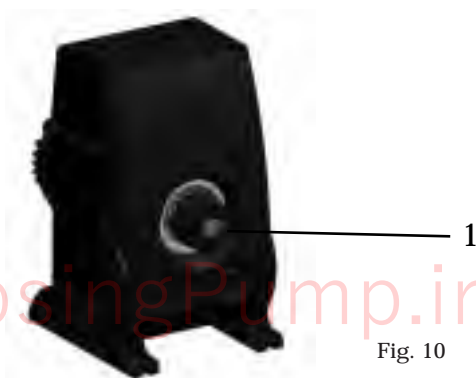
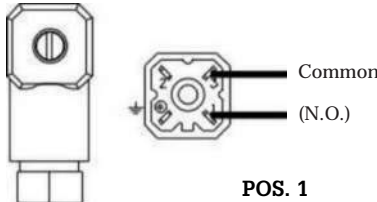

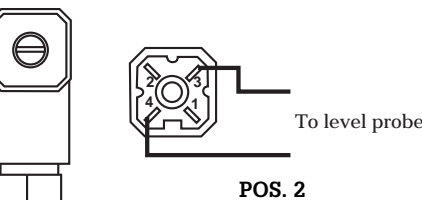
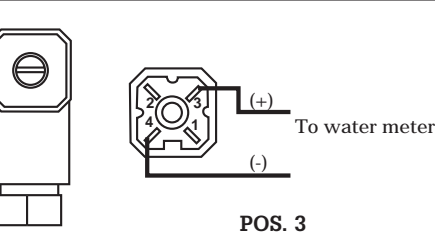

Fig. 10

3.3 - WIRING CONNECTION AND OUTPUT CONNECTOR FUNCTIONS

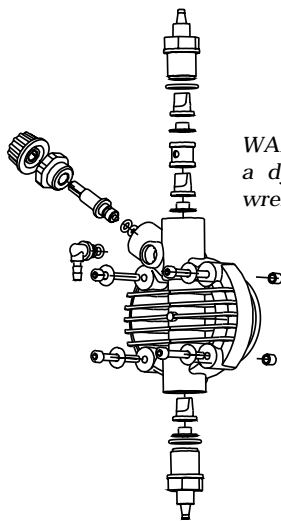

Fig. 11

Female service connector wire assembly	Functions and technical informations
 <p style="text-align: center;">POS. 1</p>	<p>Relay service output connection</p> <p>Configuration: Pin 1 = Normally Open " 2 = Not connected " 3 = Common  = Not connected</p>
 <p style="text-align: center;">POS. 2</p>	<p>Level probe connection</p> <p>Configuration: Pin 1 = Not connected " 2 = Not connected " 3 = Level probe wire " 4 = Level probe wire</p>
 <p style="text-align: center;">POS. 3</p>	<p>Pulse emitting water meter connection</p> <p>Configuration: Pin 1 = Not connected " 2 = Not connected " 3 = Water meter signal wire " 4 = Water meter signal wire</p>

4.0 - MAINTENANCE

1. Periodically check the chemical tank level to avoid the pump operating without liquid. This would not damage the pump, but may damage the process plant due to lack of chemicals.
2. Check the pump operating condition at least every 6 months, pump head position, screws, bolts and seals; check more frequently where aggressive chemicals are pumped, especially:
 - pulse and power L.E.D.;
 - the additive concentration in the pipework; a reduction of this concentration could be caused by the wearing of the valves, in which case they need to be replaced (Fig. 12) or by the clogging of the filter which then has to be cleaned as in point 3 here below.



WARNING: to tightening the four screws, use a dynamometric screw driver, set the torque wrench to 1,8N x m.

Fig. 12

3. The Company suggests periodically cleaning off the hydraulic parts (valves and filter). We cannot say how often this cleaning should be done as it depends on the type of application, we also cannot suggest what cleaning agent to use as this will depend on the additive used.

Operating suggestions when dosing sodium hypochlorite (most frequent case):

- a - disconnect the pins from the mains or by means of a onnipolar switch with 3 mm minimum distance between the contact.
- b - disconnect discharge hose from pipework;
- c - remove the suction hose (with filter) from the tank and dip it into clean water;
- d - switch on the metering pump and let it operate with water for 5 to 10 minutes;
- e - switch OFF the pump, dip the filter into a hydrochloric acid solution and wait until the acid finishes cleaning;
- f - switch ON the pump again and operate it with hydrochloric acid for 5 minutes in a closed-circuit, with suction and discharge hose dipped into the same tank;
- g - repeat the operation with water;
- h - re-connect the metering pump to the pipework.

5.0 - HOW TO OPERATE WHEN DOSING SULPHURIC ACID (50% MAX)

In this case it is essential to bear in mind the following:

1. replace PVC crystal suction hose with polyethylene discharge hose;
2. empty any residual water from the pump head beforehand.

Warning: if the water mixes with sulphuric acid it can produce a large quantity of gas with consequent overheating of the area causing damage to valves and pump head.

This operation can also be done with the pump disconnected from the plant by turning the pump upside-down for 15 to 30 seconds and without connecting the hose to the nipples; if impossible, dismount and remount the pump head (Fig. 12) using the four mounting screws.

DosingPump.ir

DLX(B) VFT/MBB

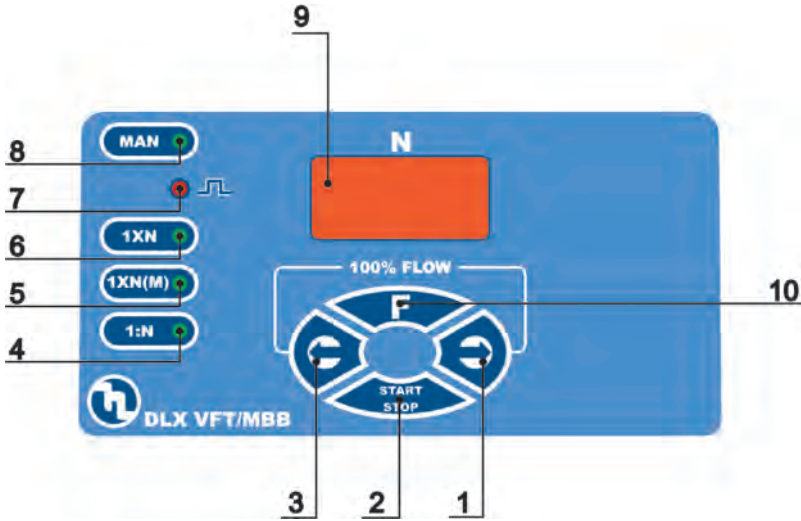

Fig. 13

6.0 - DLX & DLX/B VFT/MBB MICROCONTROLLER DOSING PUMPS

The pump is equipped with a modern microcontroller allowing design of a extremely compact and reliable electronic device.

6.1 - PUMP CONTROLS (Fig. 13)

- 1 - Increasing values button
- 2 - ON/STAND BY button
- 3 - Decreasing values button
- 4 - "green" LED 1:N function
- 5 - "green" LED 1XN (M) function
- 6 - "green" LED 1XN function
- 7 - "red" LED injection pulse flashing
- 8 - "green" LED MANUAL function
- 9 - 7 segment display
- 10 - function selection button

6.2 - TYPICAL INSTALLATION (Fig.14)

- A Injection valve
- B Power supply
- C Filter
- D Level probe
- I Chemical tank
- K Pulse emitting water meter
- S Process tank

6.3 - ACCESSORIES

- 1 flexible PVC suction hose, transparent crystal type, length 2 m;
- 1 semirigid polyethylene hose, white, 2 m;
- 1 injection valve 3/8 BSP m;
- 1 filter;
- 1 instructions/operating booklet.

6.4 - LEVEL CONTROL

The dosing pump is supplied with level control setting. When the chemical tank is empty, on display (9) it appears All and the pump goes in stand by. The level control has 5 seconds of delay.

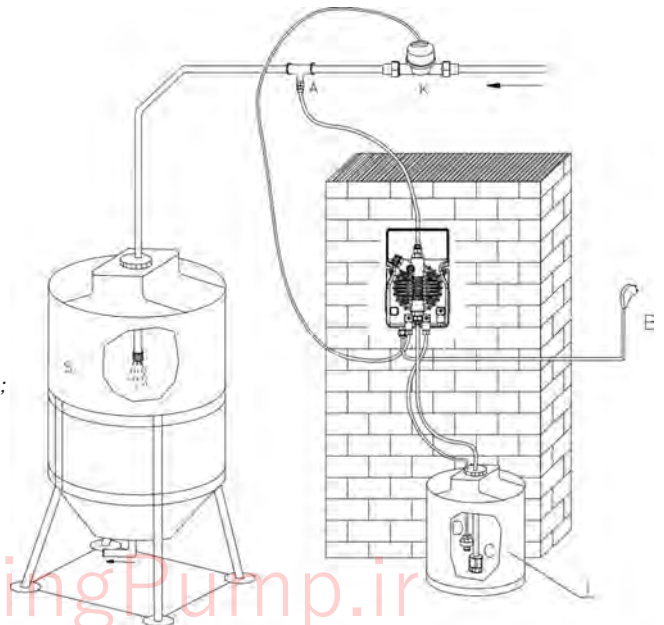



Fig. 14

7.0 - VFT/MBB FEATURE DESCRIPTION

Utilising the "F" function button enables simple selection of one of the below modes. When the LED is energized and flashing next to the mode required, the operator must adjust the value "N" using the   arrows. Setting is confirmed by pressing the START/STOP button.

MANUAL Mode

Unit runs at flow rate set on "N" - adjustable 10-100%

1XN Mode

Let's see how the pumps works with an example:

- Pump set in water meter 1XN mode

- Set value on "20"

- At the time the water meter gives a pulse to the pump, it starts its 20 dosing injection strokes, if during this phase further shuts of the contact occur, these are neglected. Ended up the 20 injections, the pump is waiting for further pulses from the water meter to restart the dosing cycle.

1XN(M) Mode

The pump is operated by an impulse produced by an external device (e.g. pulse emitting water meter) and it supplies a number of injections equal to the value visualized on the display "N" (set by the operator). The injections are distributed with a variable frequency that depends by the time passed between a water meter pulse (produced by water meter) and the other.

Possible impulses (contacts) that may arrive to the pump while is already dosing are saved in the memory of the microcontroller, these will be delivered after the first batch is dosed.

Let's see how the pump works with an example:

The pump receives the first contact and returns a string "N" injections to the maximum frequency (e.g. 120 imps./min).

To the arrival of the second contact, the pump computes the time "T" spent by the arrival of the first one and it returns a string of "N" injections not more to the maximum frequency but to that it allows to uniformly distribute them in the time "T".

In case such time reduces, the pump keeps into consideration the injections "N1" which have not been delivered and add them to the "N" ones still not delivered. There are no problems if the time occurred between the contacts should length. If instead quick contacts occurs and it goes to condition $N1 > 4 \text{ times } N$, the pump goes in alarm (on the display $\Delta 3$ is visualized) but continues working and maintaining all the parameters set before by the operator but not dosing the strokes related to the last water meter pulses "N".

1:N Mode

The pump supplies an injection of chemical only when it has reached a number of pulses (contacts), equal to the value visualized on the display (set by the operator)



Let's see how it works with an example:

- Pump set with water meter 1:N

- Set value on "20"

- While the water meter supplies 20 pulses the pump discharge 1 stroke.

PRIMING (100% flow)

is possible in all meter modes by pressing and holding   simultaneously.

8.0 INPUT/OUTPUT EXTERNAL CONNECTIONS (FOR EXTERNAL ACCESSORY)

As shows on paragraph 3.3 the three connectors are used for connecting the accessories.

Namely the accessories are:

- Level control switch;
- Water meter input (Reed switch type);
- Output service relay

It is very important to disconnect the power from the pump when connecting the accessories. It is also very important to protect the unutilized connectors with male connectors supplied with the pump.

Such operation will protect the internal circuitry from unwanted shorts and/or the power surge either from the operator or from different sources. There will be no accessible contacts after installation is completed.

It is imperative that the accessories will be supplied by the factory to avoid unwanted mismatched situations and/or furthered possible damage (which in this case will be not covered by the warranty).

Further more cables and accessories must be idoneous and rated for the proper voltage and type of insulation.

SUMMARY OF TYPE OF CONNECTIONS

1. **INPUT LEVEL SWITCH:** as shown on paragraph 3.3 the pins #3-4 from position 2 are dedicated to the operation of the level sensor. Such operation is activated by a float containing one magnet if the liquid is below the position or completely absent the float will slide down activating a reed switch.

3. **INPUT FROM WATER METER:** our pump (pins #3-4 from position 3) can be connected to a water meter generating reed switch signal proportional to a certain quantity of water passing through out. It must be clear that such signal are only of ohmic nature and they do not carrying any power.

Connecting to the pump a different type of water meter generating any voltage will irrevocably damage the pump thus avoiding any warranty.

4. **OUTPUT SERVICE RELAY:** such relay utilize the pins #1-3 (connector #1 paragraph 3.3) which are activated in case of alarm status.

9.0 - TROUBLE-SHOOTING COMMON TO DLX AND DLX/B SERIES

9.1 - MECHANICAL FAULTS

As the system is quite robust there are no apparent mechanical problems. Occasionally there might be a loss of liquid from the nipple because the tube nut has loosened, or more simply the discharge tubing has broken.

Very rarely there may be losses caused by the breakage of the membrane, or by the membrane seals in which case they have to be replaced by disassembling the four screws of the pump head (fig. 12), when re-mounting the pump head ensure that the screws are replaced properly, along with "O" ring.

After repair, the metering pump will need to be cleaned of additive residues which can damage the pump casing.

① THE METERING PUMP GIVES PULSES BUT THE ADDITIVE IS NOT INJECTED

a. Dismount the suction and discharge valves, clean them and replace, see position (fig. 11). Should the valves be swollen, check valves material against our chemical resistance compatibility chart and fit correct valves. Standard valves are Viton. Upon request ball check valve, can be supplied.

b. Check clogging of the filter.

ATTENTION: When removing the metering pump from the plant, be careful as there might be some residual additive in the discharge hose.

9.2 - ELECTRICAL FAULTS

① ALL LEDS OFF, THE PUMP DOES NOT PULSE

Check power supply (socket, plug, power switch ON), if the pump doesn't work contact manufacturer Customer Service, Dealer or Distributor.

② GREEN LED (POWER) ON, RED LED (PULSE) OFF, THE PUMP DOES NOT PULSE

Press the START/STOP button. If the pump is in water meter mode check the water meter connection. If the pump doesn't work contact manufacturer Customer Service, Dealer or Distributor

③ PUMP PULSES ARE NOT CONSTANT

Check that supply voltage is within +/- 10% of rated voltage.

④ THE DOSING PUMP GIVES ONLY ONE PULSE

Disconnect the equipment and contact manufacturer Customer Service, Dealer or Distributor.



ETATRON D.S.

HEAD OFFICE - ITALY

Via dei Ranuncoli, 53 - 00134 ROMA - ITALY

Phone +39 06 93 49 891 - Fax +39 06 93 43 924

e-mail: info@etatronds.com - web: www.etatronds.com

ITALY (BRANCH OFFICE)
ETATRON D.S.
Via Ghisalba, 13
20021 Ospiate di Bollate
(MI) ITALY
Phone +39 02 35 04 588
Fax +39 02 35 05 421

ASIA ETATRON D.S.
(Asia-Pacific) PTE Ltd
67 Ubi Crescent, #03-05
Techniques Centre
Singapore 408560
Republic of Singapore
Phone +65 67 43 79 59
Fax +65 67 43 03 97

USA - CANADA - MEXICO
ETATRON AMERICA
1642 McGaw Avenue
Irvine, CA 92614
USA
Phone +1 949 251 8700
Fax +1 949 752 7867

ESPAÑA - ETATRON
DOSIFICACION Y MEDICION S.L.
Avda. Letxumboro 83
Pabellón 6
Irún (20305) ESPAÑA
Phone +34 902 09 93 21
Fax +34 943 09 03 12
www.etatron.es

BRASIL
ETATRON do Brasil
Rua Vidal de Negreiros, 108
Bairro Canindé - CEP 03033-050
SÃO PAULO SP
BRASIL
Phone/Fax +55 11 3228 5774

RUSSIAN FEDERATION
DOSING SYSTEMS
3-rd Mytishenskaya, 16/2
129626 Moscow
RUSSIA
Phone +7 495 787 1459
Fax +7 495 787 1459

UKRAINE
000 ETATRON - UKRAINE
Soborna Street, 446
Rivne, 33024 Rivne Region
UKRAINE
Phone +380 36 26 10 681
Fax +380 36 26 22 033

UNITED KINGDOM
Etatron GB
Lindum Business Park
Station Road North Hykeham
Lincoln, LN6 3QX UK
Phone +44 (0) 1522 85 23 97
Fax +44 (0) 1522 50 03 77

ETATRON FRANCE
1 Mail Gay Lussac
95000 Neuville Sur Oise
Tel: +33 (0)1 34 48 77 15
Fax: +33 (0)1 78 76 73 95

DosingPump.ir

A B

COD. ÖT WÄCFI HT ŠFÖZG HÖCFD