

# Operation Manual Conductive Conductivity and Temperature Transmitter

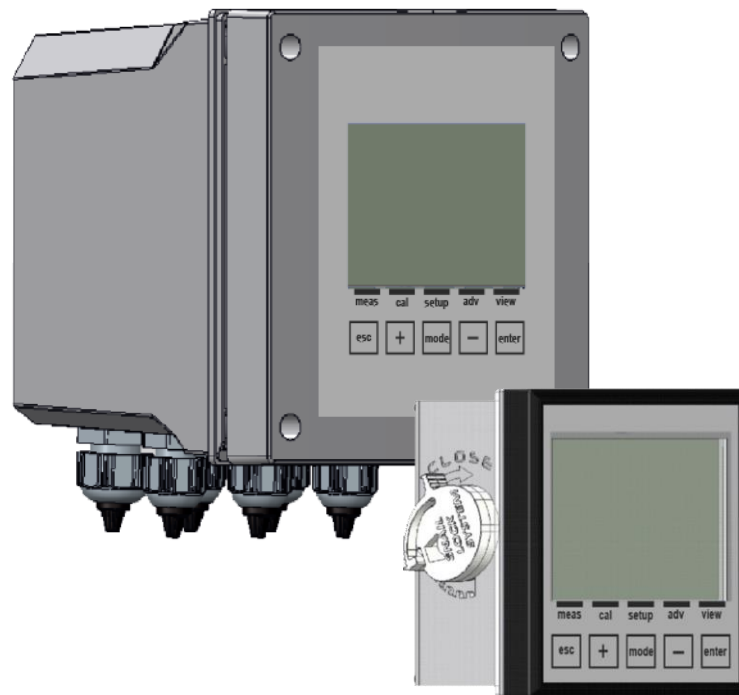

DosingPump.ir

<b>GENERAL .....</b>	<b>4</b>
INFORMATION REGARDING THE MANUAL .....	4
LIMITATIONS OF USE AND SAFETY PRECAUTIONS .....	4
INFORMATION ON RECYCLING AND USE OF MATERIALS.....	6
<b>GENERAL DESCRIPTION .....</b>	<b>7</b>
MEASURING PRINCIPLES .....	7
MAIN CHARACTERISTICS.....	8
CONTROLS, INDICATORS AND CONNECTIONS.....	9
GRAPHIC DISPLAY .....	10
<b>INSTALLATION .....</b>	<b>11</b>
INSTALLING THE CENTRAL UNIT ON THE WALL.....	11
INSTALLING THE CENTRAL UNIT ON A PANEL .....	12
CONNECTION TO THE POWER SUPPLY .....	13
CONNECTION TERMINAL BLOCK FOR THE WALL MOUNTED DEVICE.....	15
<b>STARTUP.....</b>	<b>17</b>
ALARMS MENU.....	18
INFO MENU .....	18
<b>CALIBRATION MENU (INDEX MENU 1) .....</b>	<b>19</b>
CALIBRATION PROCEDURE .....	20
CALIBRATION ERRORS .....	25
<b>SETUP MENU (INDEX MENU 2) .....</b>	<b>27</b>
SETUP MENU \ RELAY 1 (ONE) (INDEX MENU 2A) .....	28
SETUP MENU \ RELAY 2 (TWO) (INDEX MENU 2B).....	29
SETUP MENU \ SSR1 (INDEX MENU 2C) .....	30
SETUP MENU \ OUTPUT MA1 (INDEX MENU 2D).....	31
<b>ADVANCED MENU (INDEX MENU 3) .....</b>	<b>32</b>
ADVANCED MENU \ LANGUAGE (INDEX MENU 3A).....	33
ADVANCED MENU \ PASSWORD (INDEX MENU 3B) .....	34
ADVANCED MENU \ DISPLAY (INDEX MENU 3C).....	35
ADVANCED MENU \ CHEMICAL MEASURE (INDEX MENU 3D).....	36
ADVANCED MENU \ TEMPERATURE MEASURE (INDEX MENU 3E) .....	38
ADVANCED MENU \ CELL CONSTANT (INDEX MENU 3F) .....	40
ADVANCED MENU \ ALARMS CONFIGURATION (INDEX MENU 3G).....	41
ADVANCED MENU \ OUTPUTS CONFIGURATION (INDEX MENU 3H).....	42
ADVANCED MENU \ CONTROL PANEL (INDEX MENU 3I) .....	43
ADVANCED MENU \ STATISTICS (INDEX MENU 3L).....	43
ADVANCED MENU \ RESET INSTRUMENT (INDEX MENU 3M) .....	44
ADVANCED MENU \ FIRMWARE REVISION (INDEX MENU 3N) .....	44
<b>VIEW MENU (INDEX MENU 4).....</b>	<b>45</b>
<b>GENERAL SPECIFICATIONS .....</b>	<b>46</b>
MECHANICAL SPECIFICATIONS FOR VERSION 1/4DIN .....	46
MECHANICAL SPECIFICATIONS FOR VERSION 1/2DIN .....	46
ENVIRONMENTAL SPECIFICATIONS FOR VERSION 1/2DIN & 1/4DIN.....	46
ELECTRICAL SPECIFICATIONS .....	47

ANNEX A: ON/OFF RELAY SETUP .....	48
ANNEX A: ON/OFF RELAY SETUP WITH OFA FUNCTION .....	49
ANNEX B: TIMED RELAY SETUP .....	50
ANNEX B: TIMED RELAY SETUP WITH OFA FUNCTION. ....	51
ANNEX C: PROPORTIONAL (PWM) RELAY SETUP .....	52
ANNEX C: PROPORTIONAL (PWM) RELAY SETUP WITH OFA FUNCTION.....	53
ANNEX D: RELAY 2 SETUP FOR AUTOMATIC WASHING.....	54
ANNEX E: RELAY 2 SETUP TO REPEAT REMOTE ALARM.....	55
ANNEX F: SSR1 SETUP .....	56
ANNEX G: MA1 SETUP .....	57
ANNEX H: WIRING EXAMPLES.....	58
ANNEX I: TROUBLESHOOTING. ....	60
ANNEX L: DEFAULT PARAMETERS TABLE AND RESET TO DEFAULT.....	61
RESET THE DEFAULT PARAMETERS OF THE INSTRUMENT .....	64



**Note:** All the strings representing programming menus in this manual are indicative only. The strings displayed by the instrument have been shortened for proper readability and viewing on the display.

# GENERAL

## INFORMATION REGARDING THE MANUAL

Compliance with the operative procedures and the precautions described in this manual is an essential requirement for the correct operation of the instrument and to guarantee total operator safety.

Before using the instrument, the manual must be read in all of its parts, in the presence of the instrument itself, in order to ensure that the operating modes, the controls, the connections to the peripheral equipment and the precautions for safe and correct use are clearly understood.

The user manual must be stored, integral and legible in all parts, in a safe place which can be quickly and easily accessed by the operator during installation, use and/or installation revision operations.

## CONVENTIONS

The present user manual uses the following conventions:

### NOTE



The notes contain important information to be highlighted in comparison to the rest of the text. These generally contain information that is useful to the operator to carry out and optimize operating procedures of the equipment in a correct manner.

### WARNING



Warning messages appear in the manual before procedures or operations that must be observed in order to avoid any possible losses of data or damages to the equipment.

### ATTENTION



Attention messages appear in the manual in correspondence to description of procedures or operations which, if carried out incorrectly, may cause damages to the operator or users.

## LIMITATIONS OF USE AND SAFETY PRECAUTIONS

In order to guarantee operator safety and correct device functionality, all of the usage limitations and precautions listed below must be respected:

### ATTENTION



Make sure that all the safety requirements have been met before using the device. The device must not be powered on or connected to other devices until all of the safety conditions have been met.

## ELECTRICAL SAFETY

### ATTENTION



All of the control unit's connections are isolated from the grounding system (non-insulated grounding conductor).  
DO NOT connect any of these connections to the grounding connector.

DosingPump.ir

In order to guarantee maximum conditions of safety for the operator, it is recommended to follow all of the indications listed in this manual.

- **Power the device only using a mains power supply that complies with the device's specifications: 230Vac, 115Vac or 24Vac 50/60Hz.**
- **Replace any damaged parts immediately.** Any cables, connectors, accessories or other parts of the device which are damaged or not functioning properly must be replaced immediately. In such cases, contact your nearest authorized technical assistance center.
- **Only use specified accessories and peripherals.** In order to guarantee all of the safety requirements, the device must only be utilized in conjunction with the accessories specified in this manual, which have been tested for use with the device itself. The use of accessories and consumption materials from other manufacturers or not specifically recommended by supplier will not guarantee the safety and correct operation of the equipment. Only use peripherals that comply with the regulations of their specific categories

## SAFETY OF THE OPERATING ENVIRONMENT

- The panel of the control unit is resistant to liquids. The device must be protected against drips, sprays and/or immersion and should not be used in environments where such risks are present. Any devices into which liquids may have accidentally penetrated must be immediately shut off, cleaned and inspected by authorized and qualified personnel.
- The transparent panel should be closed once the device has been programmed.

### Protection

For **Wall Mounted** device (1/2 DIN)

- IP65 Complete
- EMI /RFI CEI EN55011 - 05/99 Class A

For **Panel Mounted** device (1/4 DIN)

- IP65 Front and IP20 Back
- EMI /RFI CEI EN55011 - 05/99 Class A

**The device must be utilized within the specified environmental temperature, humidity and pressure limits.** The instrument is designed to operate under the following environmental conditions:

- |   |                         |
|---|-------------------------|
| - Temperature of the working environment  | -10 ÷ +50°C             |
| - Storage and transport temperature       | -25°C ÷ +65°C           |
| - Relative Humidity Box 96x96 (1/4 DIN)   | 0% ÷ 95% Non-Condensing |
| - Relative Humidity Box 144x144 (1/2 DIN) | 0% ÷ 100% Condensing    |

## ATTENTION

**The device must be perfectly inserted into the system.**

**The system must be maintained operational in full compliance with the foreseen safety regulations.**

**The parameters set on the analyzer's control unit must comply with the current regulations.**

**The control unit's malfunction signals must be located in an area that is constantly supervised by the system's maintenance personnel or operators.**

**Failure to respect even just one of these conditions could cause the control unit's "logic" to operate in a potentially dangerous manner for the users of the service.**

**In order to avoid any potentially dangerous situations, therefore, the system's service and/or maintenance personnel are advised to work with the utmost care and to signal any alterations in the safety parameters in a timely manner.**

**As the above issues cannot be monitored by the product in question, the manufacturer shall bear no responsibility for any property damage or personal injury which may result from such malfunctions.**



DosingPump.ir

## ATTENTION SYMBOL

The symbol illustrated below represents the **ATTENTION** symbol and reminds the operator that he should read the user manual for important information, advice and suggestions regarding the correct and safe use of the equipment.



In particular, when it is positioned close to connection points to cables and peripherals, the symbol in question refers to careful reading of the user manual for instructions related to the nature of such cables and peripherals and the methods for correct and safe connection.

The reproductions of equipment panels, with relative commands, connections, symbols and labels are provided in this chapter. Each attention symbol is accompanied by a detailed explanation of its meaning.

## PLATE DETAILS

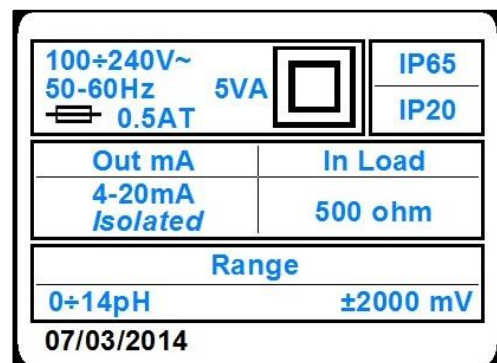
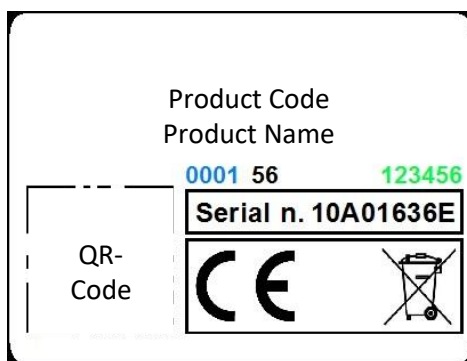

## INFORMATION ON RECYCLING AND USE OF MATERIALS

The supplier, in accordance with specific European regulations, aims at constant improvement of development and of production procedures of its equipment with the objective of drastically reducing the negative impact on the environment caused by parts, components, consumption materials, packaging and the equipment itself at the end of its life cycle.

The packages are designed and produced to allow the reuse or recovery, including recycling, of the great part of the materials and to minimize the amount of waste or residues to be disposed. In order to assure a correct environmental impact, the equipment has been designed with the smallest circuit possible, with the lowest differentiation of materials and components, with a selection of substances that guarantee utmost recycling and maximum reuse of the parts and waste disposal free from ecological risks.

The equipment is made in such a way as to guarantee the easy separation or dismantling of the materials containing contaminants in comparison with others, in particular during maintenance operations and the replacement of components.

## ATTENTION



**The disposal/recycling of packages, consumption materials and of the equipment itself at the end of its life cycle must be carried out in accordance to the standards and regulations currently in force in the country where the equipment is used.**

## SPECIAL ATTENTION TO CRITICAL COMPONENTS

The instrument is provided with a liquid crystal display LCD, which contains small amounts of toxic materials.

DosingPump.ir

## GENERAL DESCRIPTION

The analyzer treated in this manual consists of an Electronic Control Unit and a Technical Manual. The Control Unit can be either panel mounted or wall mounted, at a maximum distance of 50 meters from the probe.

It is powered from the mains (230Vac, 115Vac or 24Vac 50/60Hz), with a power consumption of 3.6VA, through a linear power supply.

This device has been designed to analyze ON-LINE the Conductivity values in different applications:

- Cooling Towers
- Treatment and Discharge of Industrial Water
- Reverse Osmosis

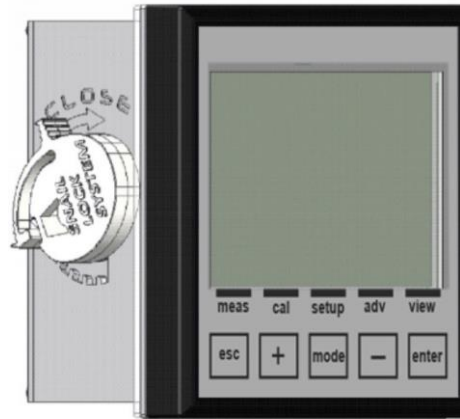

Figure 1 – Wall mounted Central Unit for Conductivity and Temperature Measures

## MEASURING PRINCIPLES

### CONDUCTIVITY METER

The electrical conductivity measure expresses the ionic concentration in a solution.

The greater the amount of salts, acids, or even bases in the solution, the greater the conductivity.

The unit of measure for conductivity is Siemens/cm. The measuring range for aqueous solutions starts with the ultra-pure water which has a conductivity of 0.05  $\mu\text{S/cm}$  (25°C). The natural water, such as drinking water or surface water, has a conductivity of about 100...1000  $\mu\text{S/cm}$ . The maximum value of the range is reached by some bases, such as potassium hydroxide, with values slightly greater than 1000 mS/cm.

The conductivity measure is particularly used in the water analysis (drinking water, mineral water, groundwater, distilled water, demineralized water, boilers' water supply, discharge water) in the control of plating baths, in purity checks (organic substances, food substances), in thermal power plants (steam-condensate cycle control), in the food industries, sugar industries, in cellars, in the textile industry, in the automatic irrigation systems etc.

The electrical conductivity of a solution is defined as the reciprocal of the resistance of one cubic centimeter of a solution, at a predetermined temperature, i.e. the resistance measured between two electrodes with a surface of 1 cm<sup>2</sup> separated by a distance of 1 cm and immersed into a test solution.

DosingPump.ir

## MAIN CHARACTERISTICS

- Conductivity Measure
- Temperature Measure with PT100 / PT1000 Probe
- Automatic Temperature Compensation
- Programming keyboard with 5 keys
- Graphic Display, 128x128 pixels, with white backlight
- 1 Programmable Analog Output
- 1 Frequency Programmable Digital Output
- 2 Relay Outputs for Intervention Thresholds, Wash and Remote Alarm
- 1 Digital Input for blocking the dosages

### TECHNICAL SPECIFICATIONS FOR THE CONDUCTIVITY MEASURE

Probe	Range
Range with C 0.01 cm <sup>-1</sup> / K 100 sensor	0.005 μS/cm to 200 μS/cm (5 KΩ x cm to 200 MΩ x cm)
Range with C 0.10 cm <sup>-1</sup> / K 10 sensor	0.05 μS/cm to 2 mS/cm (500 Ω x cm to 20 MΩ x cm)
Range with C 0.20 cm <sup>-1</sup> / K 5 sensor	0.1 μS/cm to 4 mS/cm (250 Ω x cm to 10 MΩ x cm)
Range with C 1.00 cm <sup>-1</sup> / K 1 sensor	0.5 μS/cm to 20 mS/cm (50 Ω x cm to 2 MΩ x cm)
Range with C 10.0 cm <sup>-1</sup> / K 0.1 sensor	5 μS/cm to 200 mS/cm (5 Ω x cm to 200 KΩ x cm)
Range with C 20.0 cm <sup>-1</sup> / K 0.05 sensor	10 μS/cm to 400 mS/cm (2,5 Ω x cm to 100 KΩ x cm)
Resolution Cond/Res	0.0001 / 0.001 / 0.01 / 0.1 / 1 (adjustable from menu)
Accuracy Cond/Res	± 5% on the measuring point
Maximum distance of the sensor	up to 50 m (up to 164 ft)
TDS Range	0.3 to 2.0 ppm/μS

### TECHNICAL SPECIFICATIONS FOR THE TEMPERATURE MEASURE (SECONDARY)

<b>Sensor</b>	PT100/PT1000
<b>Measure Range</b>	0 ÷ +100°C
<b>Resolution</b>	± 0.1°C (°F)
<b>Precision</b>	±1.0°C (±1.8°F)

### OPERATING SPECIFICATIONS

<b>Power Supply</b>	230Vac, 115Vac or 24Vac 50/60Hz
<b>Power Consumption</b>	3.6VA
<b>Relay Outputs:</b>	
<b>Alarms:</b>	
<b>Function</b>	Delay, Faults and Min./Max
<b>Delay Time</b>	1÷3600sec
<b>Threshold disabling</b>	Enable / Disable
<b>Relay function</b>	Closed / Open
	For Alarm and Wash it is used the relay n. 2 with normally open contact.
<b>Analog Outputs:</b>	
<b>Outputs</b>	n.1 4-20mA Programmable
<b>Maximum Load</b>	500 Ohm
<b>NAMUR Alarm Output</b>	3.6 mA or 22 mA
<b>Hold Alarm Value</b>	



## CONTROLS, INDICATORS AND CONNECTIONS

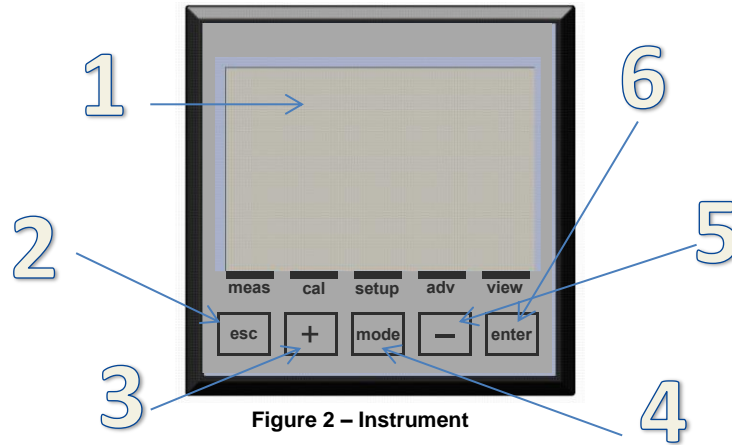

Figure 2 – Instrument

1. Visualizer with LCD Display
2. ESC key: Reject parameter or exit the programming menu
3. UP key: Increase value
4. MODE key: Select menu with icon on the status bar
5. DOWN key: Decrease value
6. ENTER key: Confirm parameter or access the programming menu

### GRAPHIC DISPLAY SUBDIVISION AREAS IN RUN MODE

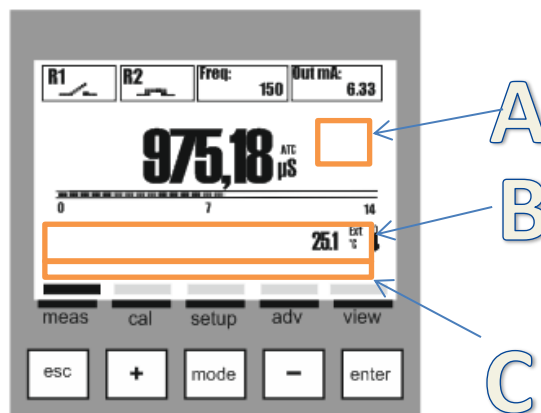

Figure 3 – Graphic Display - Subdivision Areas

In the standard view of the instrument we have three areas, as follows:

- A) Service icons such as Danger, Wait Time, Automatic Temperature Compensation ATC, Manual Temperature Compensation MTC or OTC.
- B) Text messages for Alarms and operation information or temperature value with external sensor (ext) or manually set value (man).
- C) Menu name associated to the icon on the status bar

DosingPump.ir

## GRAPHIC DISPLAY

The graphic display allows a series of views for the various menus, for programming and for viewing during operation (run).

### LIST OF THE MAIN MENUS

The following table shows the screens visualized on the display representing the different menus

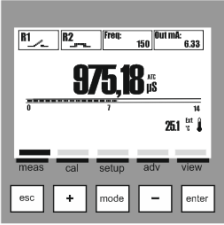
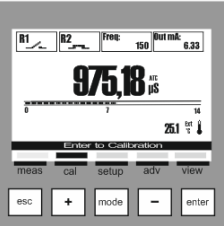
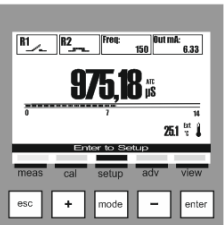
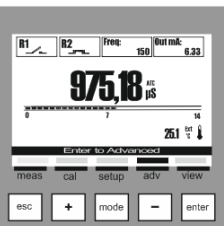
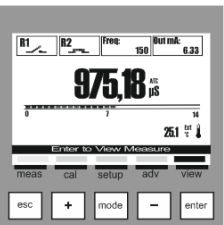
VISUALIZATION ON THE GRAPHIC DISPLAY	DESCRIPTION
	VIEW MEASURE
	CALIBRATION MENU Electrode Calibration Procedure
	SETUP MENU Output Parameters Setup
	ADVANCED MENU Device Configuration Menu
	VIEW MENU Measure Visualization Setting



**Note:** Automatic exit from menu after 5 minutes of inactivity without saving data.

# INSTALLATION

Before installing, read carefully what is written below.

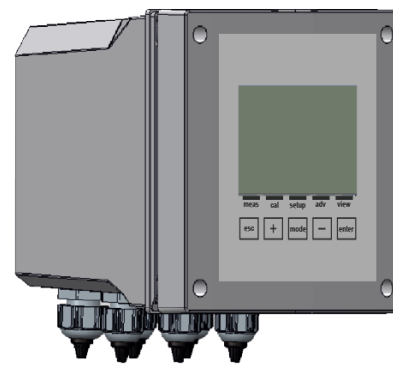

## INSTALLING THE CENTRAL UNIT ON THE WALL

The wall must be very smooth to allow the perfect adhesion of the central unit.

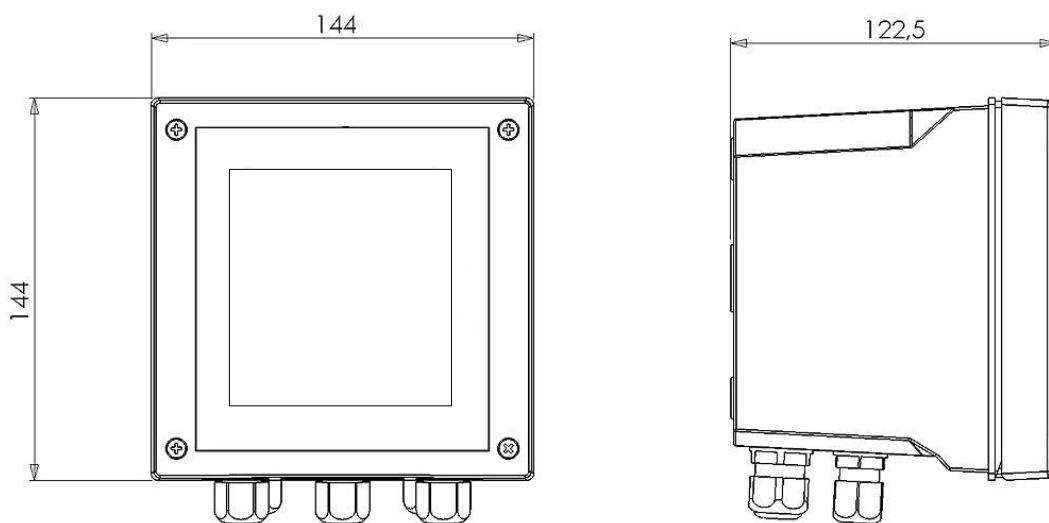

Figure 4 – Dimensions and footprint for wall mounted central unit

Mechanical Dimensions	
Dimensions (L x H x P)	144x144x122.5mm
Fixing depth	122.5mm
Material	ABS
Mounting	Wall
Weight	0.735 Kg
Front Panel	UV Resistant Polycarbonate

Open the instrument, drill the necessary holes and fasten the instrument to the wall. Cover the holes internally with the corresponding caps supplied with the instrument.

The cable glands for the electrical connections are located on the lower part of the control unit and therefore, in order to facilitate the connections, any other devices must be positioned at least at 15 cm away.

Protect the device against any drips and/or sprays of water from adjacent areas during the programming and calibration phases.

DosingPump.ir

## INSTALLING THE CENTRAL UNIT ON A PANEL

The wall must be very smooth to allow the perfect adhesion of the electrical panel where the central unit will be fitted.

The fixing depth of the panel must be at least 130 mm.

The thickness of the panel must not exceed 5 mm.

The panel cutout must comply with the following layout:

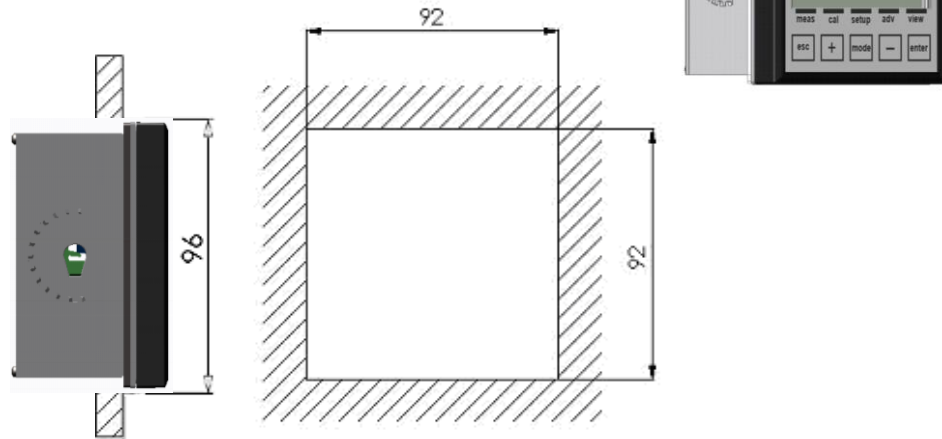

Figure 5 – Panel cutout and dimensions

Mechanical Dimensions	
Dimensions (L x H x P)	96x96x42mm
Fixing depth	130mm
Material	ABS
Mounting	Panel
Weight	0.310 Kg
Front Panel	UV Resistant Polycarbonate



The central unit can be locked on the panel using the two clamps supplied with the unit, inserted in their seats and locked with corresponding screws.



Figure 6 – Panel Mounted Central Unit with Snail Lock System

DosingPump.ir

## CONNECTION TO THE POWER SUPPLY

If possible, keep any high-power cables away from the instrument and its connection cable (these could cause inductive disturbances, especially for the analogical part of the system).

Use an alternating 100Vac to 240Vac-50/60Hz power supply – or as specified on the plate. The power supply must be as stabilized as possible.

Absolutely avoid connecting the device to rebuilt power supplies, using transformers for example, where the same power supply is also used to power other systems (perhaps of an inductive typology); this could lead to the generation of high voltage spikes which, once emitted, are difficult to block and/or eliminate.

### ATTENTION



---

**The electrical line must be equipped with an appropriate circuit breaker, in compliance with the proper installation standards**

---

It is nevertheless always a good idea to check the quality of the grounding connector. In industrial facilities, it is not uncommon to find grounding connectors that cause electrical disturbances instead of preventing them; wherever doubts should arise regarding the quality of the facility's grounding connectors, it is better to connect the control unit's electrical system to a dedicated grounding rod.

## ELECTRIC CONNECTIONS TO THE DOSING SYSTEMS (UTILITIES)

### ATTENTION



---

**Before connecting the instrument to the external Utilities, make sure that the electrical panel is turned off and that the wires from the Utilities are not live.**

---

The term "Utilities" refers to the relay outputs used in the control unit

- (SET1) for the operation of dosing pumps or control
- (SET2) for the operation of dosing pumps or control
- (ALARM) alarm command sent by the instrument to siren and/or flashing light
- (WASH) command to the washing device

### WARNING



---

**With a resistive load, each relay contact can sustain a maximum current of 5 Ampere at max. 230V.**

---

DosingPump.ir

**ATTENTION**



When a relay output is used to drive a 3<sup>rd</sup> party device with an inductive/capacitive load input (such as contactors, motors, etc.), a transient protection is highly recommended. Check 3<sup>rd</sup> party device's options. (See Figure 7)



Figure 7 – Transient protection

**ATTENTION**



Keep relay's output cable segregate from any other cable connected to the unit (see Figure 8a). 90° crossing between cables is allowed (see Figure 8b).

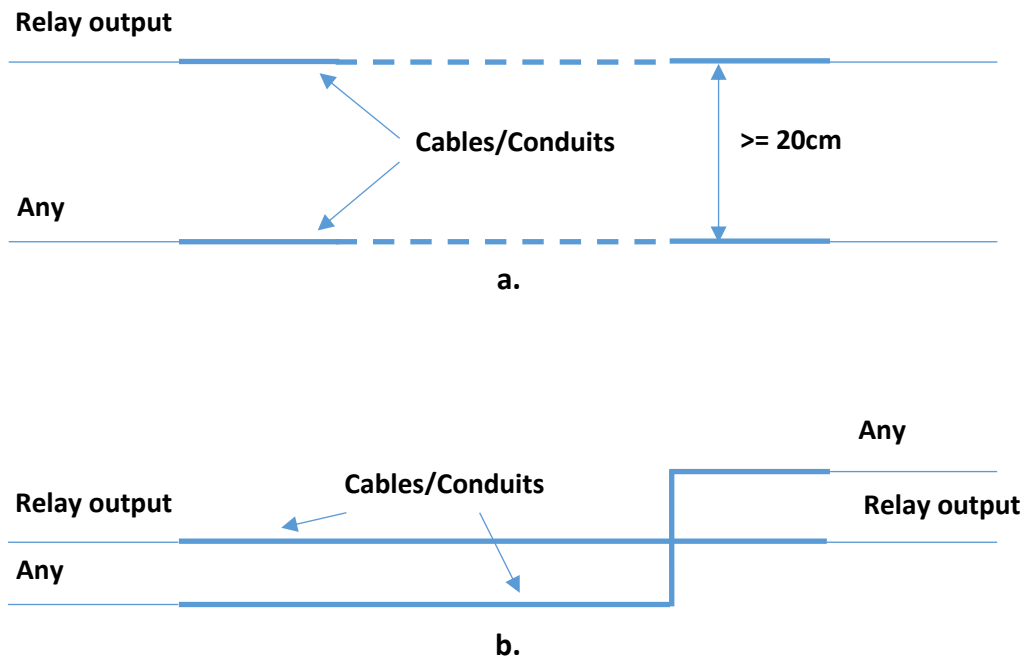
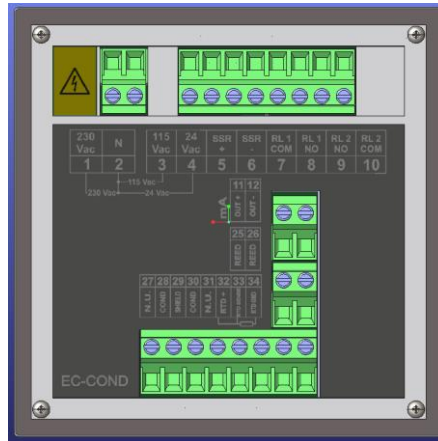

Figure 8 – Relay cable segregation

## CONNECTION TERMINAL BLOCK FOR THE WALL MOUNTED DEVICE



N° (TERMINAL)	SYMBOLS	DESCRIPTION
1	230 Vac	Power supply 230 Vac (Phase)
2	N	Power supply (Neutral)
3	115 Vac	Power supply 115 Vac (Phase)
4	24 Vac	Power supply 24 Vac (Phase)
5	SSR (+)	Frequency Output (SSR +)
6	SSR (-)	Frequency Output (SSR -)
7	RL1 COM	Relay 1 COM Contact
8	RL1 NO	Relay 1 NO Contact
9	RL2 NO	Relay 2 NO Contact
10	RL2 COM	Relay 2 COM Contact
11	OUT (+)	Current Output (OUT mA +)
12	OUT (-)	Current Output (OUT mA -)
13-24	NOT PRESENT	NOT PRESENT
25	REED	REED Sensor Input (+)
26	REED	REED Sensor Input (-)
27	N.U.	NOT USED
28	COND	Conductivity Input
29	SHIELD	Conductivity Cable Shield
30	COND	Conductivity Input
31	N.U.	NOT USED
32	RTD (+)	PT100 or PT1000 Temperature Probe Input
33	RTD SENSE	PT100 or PT1000 Temperature Probe Input
34	RTD GND	PT100 or PT1000 Temperature Probe Input

DosingPump.ir

## TERMINAL BLOCK CONNECTIONS

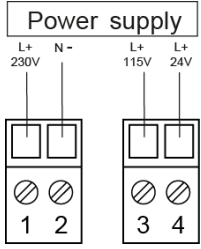
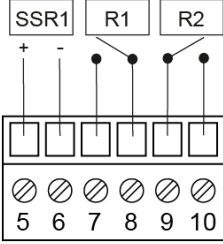
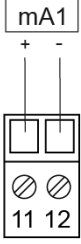
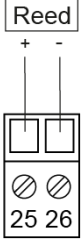
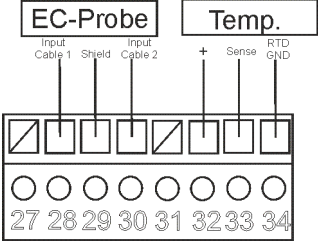
Description	Graphic
<p><b>Instrument Power Supply Input:</b> 230Vac, 115Vac or 24Vac 50/60Hz <b>Note:</b> Check the product label.</p>	
<p><b>Outputs:</b> <b>SSR1:</b> Solid State Relay (60Vac/dc, 100mA) <b>R1 and R2:</b> Electromechanical Relays (250Vac or 30VDC, 5A Resistive)</p>	
<p><b>Outputs:</b> <b>mA1:</b> Current Outputs 4÷20mA (500 ohm)</p>	
<p><b>Inputs:</b> <b>Reed:</b> Dry Contact Signal Input</p>	
<p><b>Inputs:</b> <b>Conductivity:</b> Conductivity Measure Input <b>Temp:</b> Temperature Measure Input PT100 or PT1000</p>	

(Note: See ANNEX H for Wiring Examples)

### CONDUCTIVITY PROBE CONNECTION



Turn off the instrument. Connect the cable of the electrode to the terminal block of the instrument. The maximum length of the Conductivity electrode cable (as a single element) must not exceed **50 meters**. It is also a good idea not to pass the cable near high power or inverter cables in order to avoid interference problems with the measure.

DosingPump.ir



## STARTUP

The instrument performs a hardware test of the internal memory and displays the message "**Read data memory**"

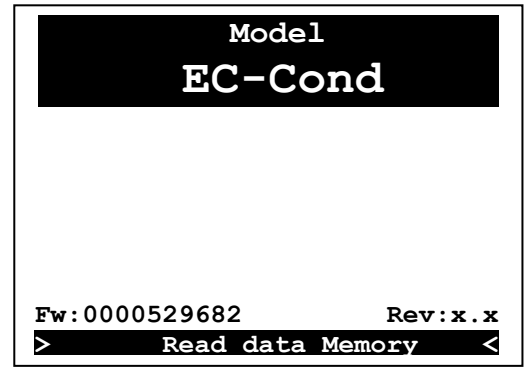

## Wait

The instrument enables all the measure functions within 5 seconds.

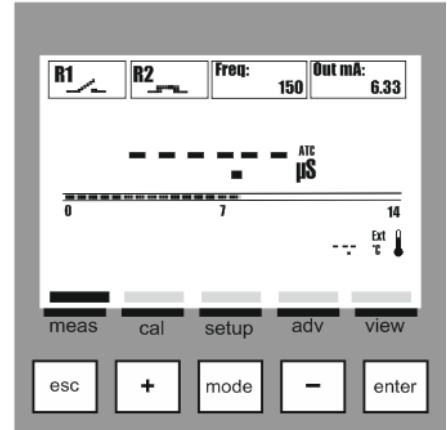

## View Measure and Outputs Activation

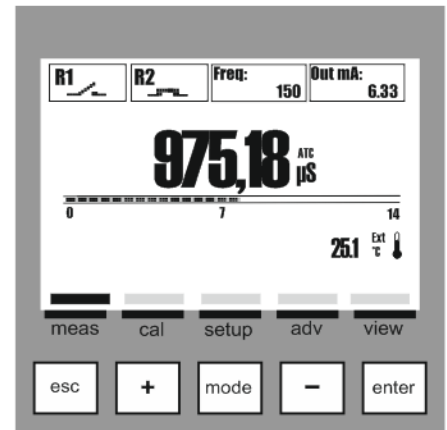



## ALARMS MENU

On **View measure** mode there is available an alarm menu which displays the alarm status by pressing the **Enter** key; the **Alarms Menu** consists of four (4) items or sub-menus:

- A: View Log:** list of all recorded alarms, starting with the most recent (Max 48 items)
- B: Reset Log:** deletes all alarm events
- C: Reset OFA:** deletes the OFA alarm and resets the counter
- D: Reset RL2 (used as alarm):**

Scroll through the menu using the **(+)** or **(-)** key, select the item and confirm with the **Enter** key.

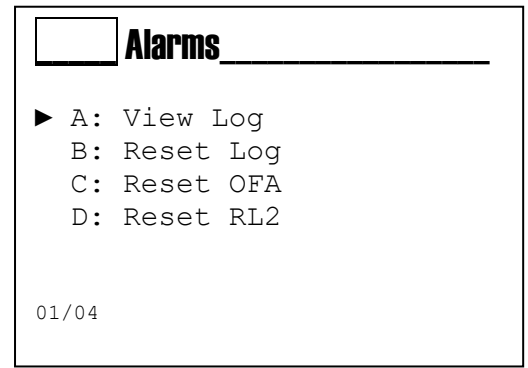

## INFO MENU

In view measure mode, press the **ESC** key to access the **Info** menu.

Select the item "Download Manual" and press the **Enter** key.

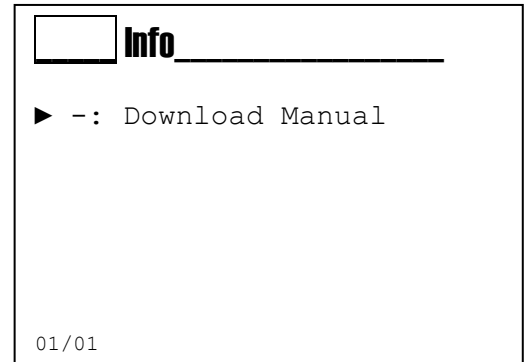

On the screen will be displayed the **WEB Link** with which you can start downloading the user manual in pdf format.

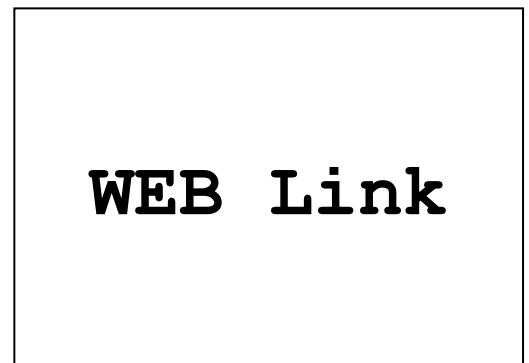

## CALIBRATION MENU (INDEX MENU 1)

Use the **MODE** key to scroll through the icons on the status bar, from left to right, select the **Calibration** menu.

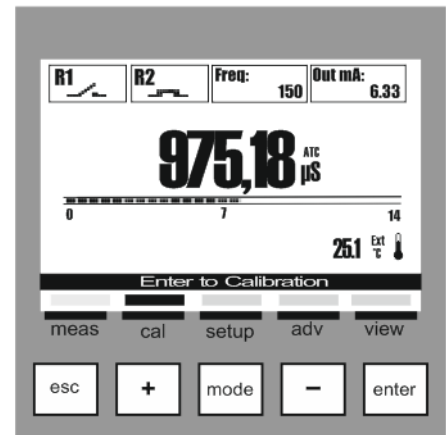

### Menu 1 Calibration

The Calibration menu consists of two (2) items or sub-menus:

- A: Conductivity Chemical Measure
- B: Temperature

Scroll through the menu using the **(+)** or **(-)** key, select the item and confirm with the **Enter** key.

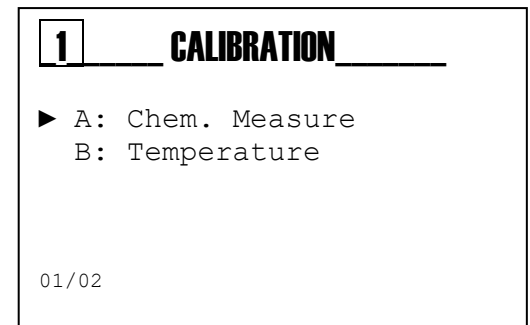

### Menu 1 Calibration Chemical Measure (Menu 1A)

The Chemical Measure menu consists of five (5) items or sub-menus:

- 1A1: **1 Point Cal**: One measure point calibration.
- 1A2: **2 Points Cal**: Two measure points calibration.
- 1A3: **Reference**: Allows you to refine the calibration by adding or subtracting an offset
- 1A4: **Report**: Will be displayed a summary of the last calibration.
- 1A5: **Reset Calibration**: The calibrations can be deleted and restored the default values.

Scroll through the menu using the **(+)** or **(-)** key, select the item and confirm with the **Enter** key.

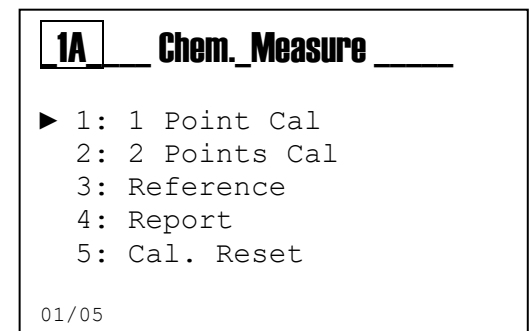

**Note:** All the calibrations must be performed with absolute conductivity values, that is to say without temperature compensation. If a reference instrument shall be used, disable the temperature compensation function.



## CALIBRATION PROCEDURE

### Calibration Menu Chemical Measure (Menu 1A)

**1A** Chem. Measure

- ▶ 1: 1 Point Cal
- 2: 2 Points Cal
- 3: Reference
- 4: Report
- 5: Cal. Reset

01/05

#### Menu 1A1 One Point Calibration

Check that the sensor is properly installed and it is measuring.

Press the **Enter** key when ready.  
Wait for 60 seconds.

**1A1** 1 Point Cal

▶: Wait  s

At the end of the countdown, insert the calibration value.

**1A1** 1 Point Cal

1: Point 1

The instrument displays a numeric keypad to insert the known value.

Press the **Enter** key when ready.

**1A1** Calibration Value

12880				µS
7	8	9		?
4	5	6		+/-
1	2	3		Canc
0	.			Enter

The instrument displays:

- 1: The calibration value used.
- 2: The calculated Gain value.
- 3: The calculated Offset value.
- 4: **Enter** to confirm and save all the calibration parameters.

**1A1** 1 Point Cal

- ▶ -: Point 1
- : Gain
- : Offset
- : Save?



The instrument displays the question to confirm and save all the calibration data.

At the end the instrument returns to Calibration menu 1.

- **Save?**

**Yes**

No

### Menu 1A2 Two Points Calibration

Check that the sensor is properly installed and it is measuring.  
Press the **Enter** key when ready.  
Wait for 60 seconds.

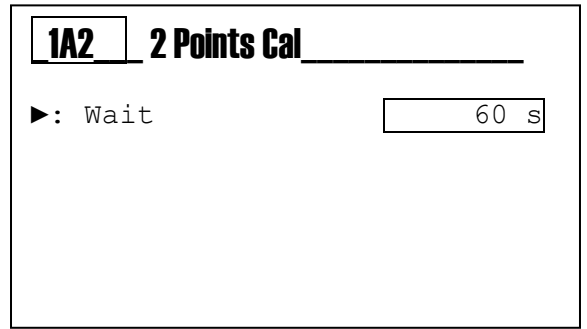

At the end of the countdown, insert the first calibration value.

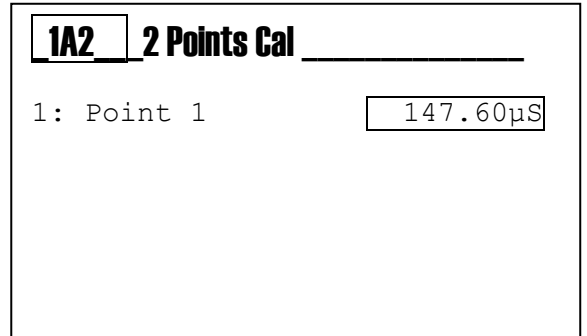

The instrument displays a numeric keypad to insert the known value.

Press the **Enter** key when ready.

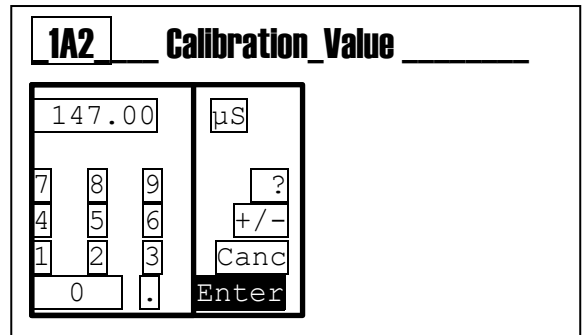

Prepare the second calibration point of the sensor.  
Insert the sensor into the second buffer solution.  
Press the **Enter** key when ready.

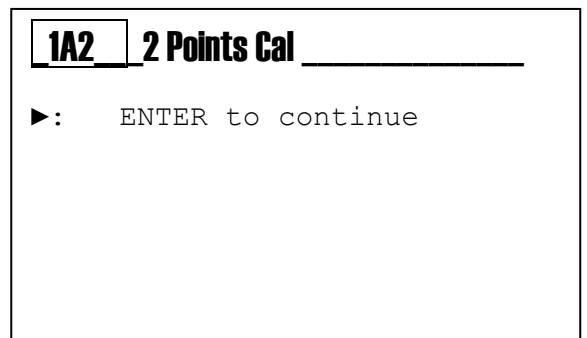

Wait for 60 seconds.

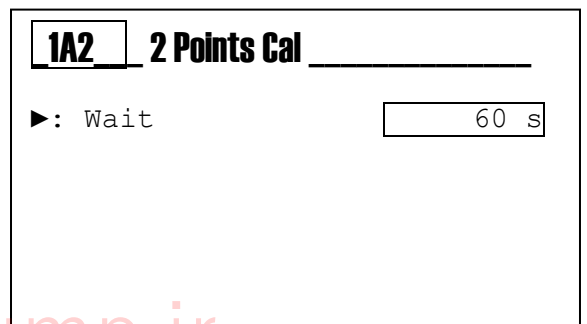

At the end of the countdown, insert the second calibration value.

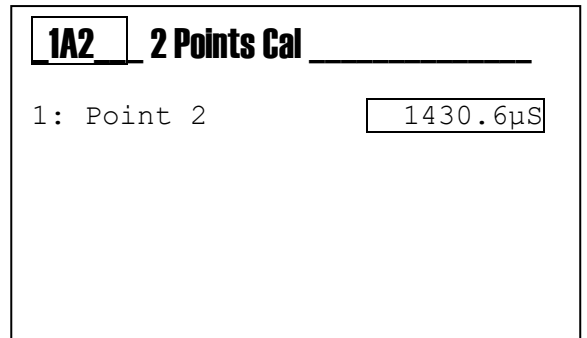

The instrument displays a numeric keypad to insert the known value.

Press the **Enter** key when ready.

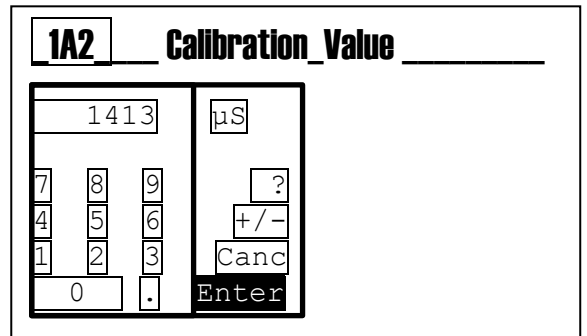

The instrument displays:

- 1: The calibration value used for the first point.
- 2: The calibration value used for the second point.
- 3: The calculated Gain value.
- 4: The calculated Offset value.
- 5: **Enter** to confirm and save all the calibration parameters.

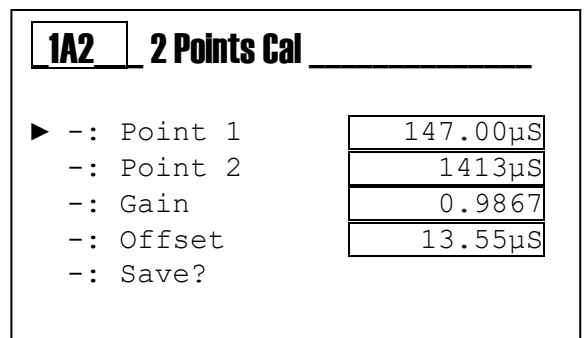

The instrument displays the question to confirm and save all the calibration data.

At the end the instrument returns to Calibration menu 1.

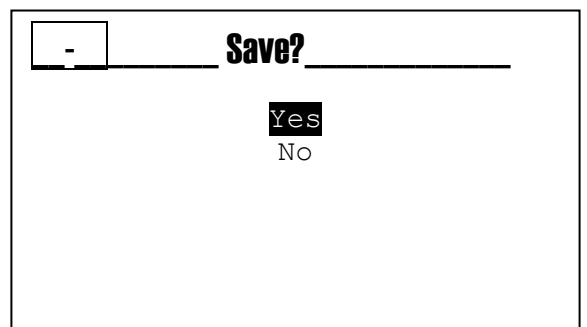

### Menu 1A3 Reference Calibration

Check that the sensor is properly installed and it is measuring.  
Press the **Enter** key when ready.

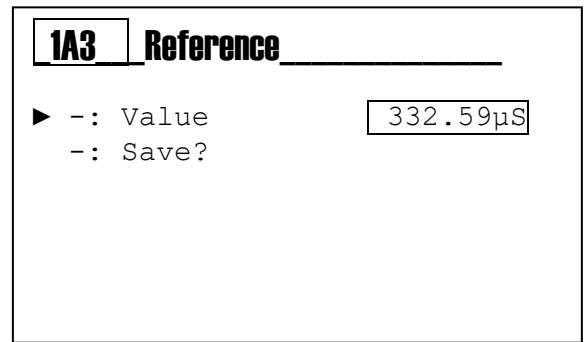

The instrument displays a numeric keypad to insert the known value.

Press the **Enter** key when ready.

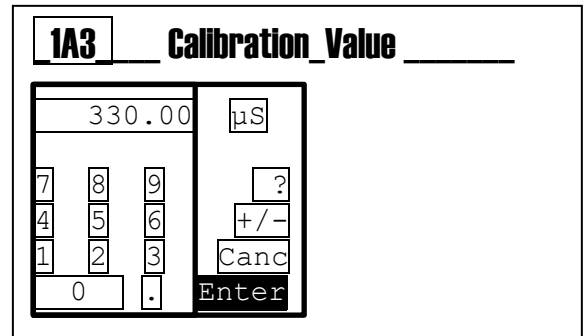

The instrument displays:  
1: The calibration value.  
2: **Enter** to confirm and save all the calibration parameters.

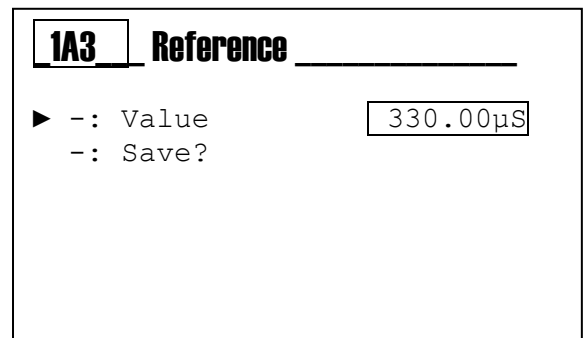

The instrument displays the question to confirm and save all the calibration data.

At the end the instrument returns to Calibration menu 1.

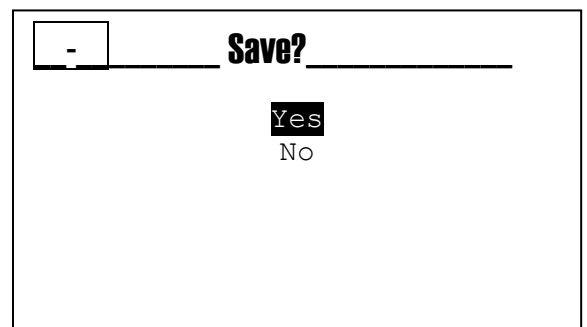

## Menu 1A4 Report

The calibration report displays all the parameters related to the last calibration.

**Calibration Type:** Indicates the calibration type,

- None
- 1 Point
- 2 Points

**Point 1:** Indicates the value entered for point 1.

**Point 2:** Indicates the value entered for point 2.

**Gain:** Indicates the calculated angular coefficient.

**Offset:** Indicates the calculated offset value.

**Adjust:** Indicates the offset value memorized through the "Reference" calibration type.



**Note:** When the calibration is performed for 1 Point or 2 Points, the "Adjust" value is automatically reset to zero.

## Menu 1A5 Reset Calibration

This function allows the user to delete all the calibrations and to restore the default values.

<b>1A4 Report</b>	
Cal. Type	2 Points Cal.
Point 1	147.00 $\mu$ S
Point 2	1413 $\mu$ S
Gain	0.9867
Offset	13.55 $\mu$ S
Adjust	-2.59 $\mu$ S

<b>1A5 Cal_Reset</b>	
Are you sure?	
<b>NO</b>	
<b>YES</b>	





## CALIBRATION ERRORS

### Probe is in Short:

- Damaged wiring
- Foreign body in contact on the electrodes

### Probe is in Air:

- Damaged wiring
- Liquid missing

### The set values must be greater than zero:

- The values set from numeric keypad must be positive and greater than zero.

### The set values must not coincide:

- Only for the 2 points calibration, the values set from numeric keypad must not coincide.

### The two calibration points must differ by at least 10%:

- The second calibration point must be greater with at least 10% compared to the first calibration point.

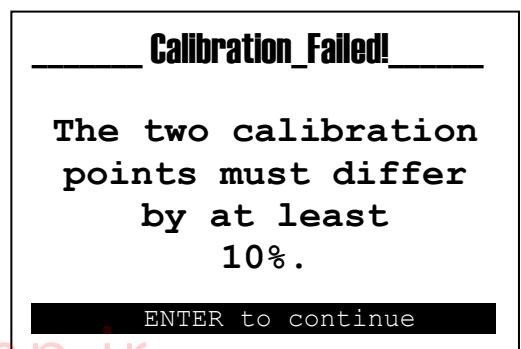
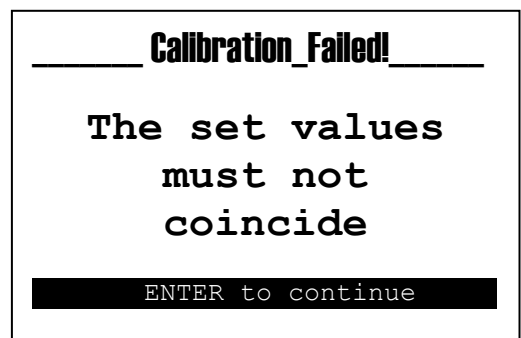
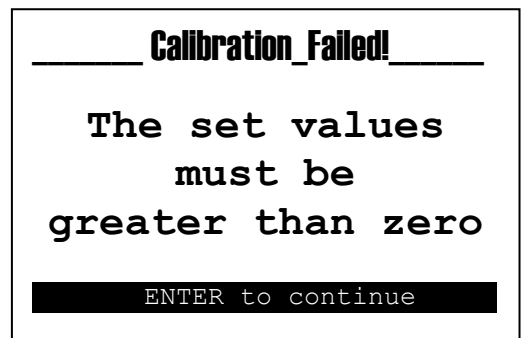
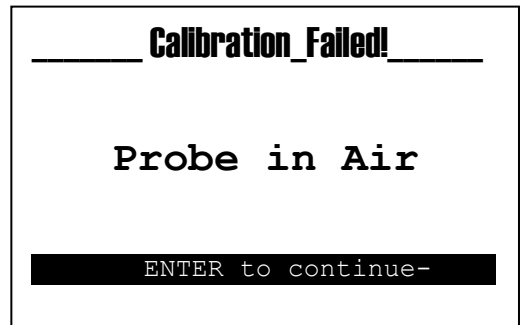
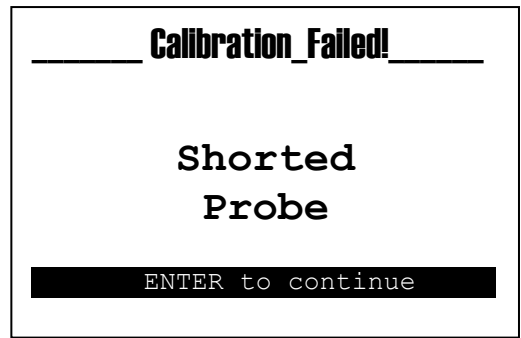

## Calibration Menu Temperature Measure (Menu 1B)

### Menu 1B

Calibration of the Temperature Measure with an external reference value, manually set. The instrument performs a correction of the value by adding an offset value to the real measure.

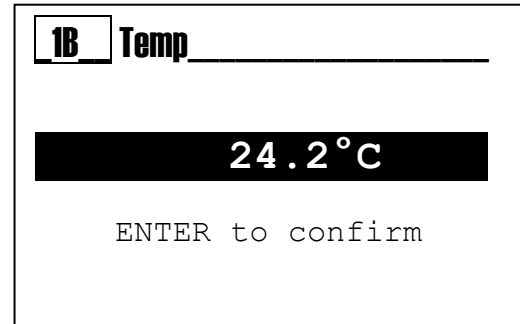

### Menu 1B

The instrument displays the message "Calibration Failed" if the probe is damaged or disabled from the menu 3E1; see manual, the Advanced Menu section.

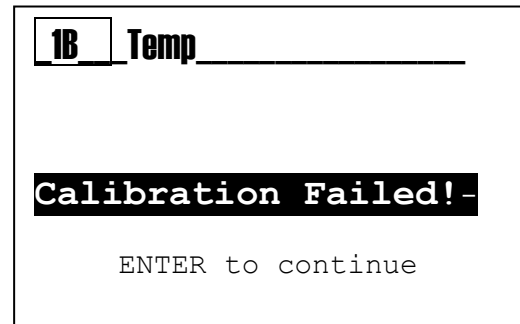

## SETUP MENU (INDEX MENU 2)

Use the **MODE** key to scroll through the icons on the status bar, from left to right, select the **setup** menu and confirm with the **Enter** key.

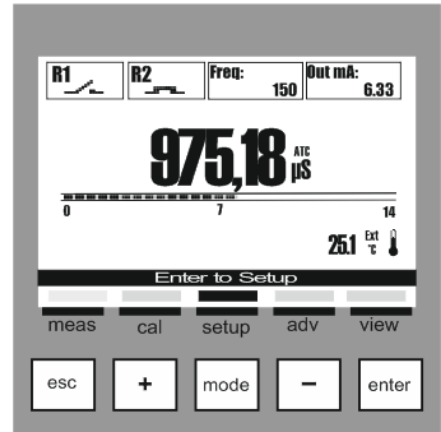

The Setup menu consists of four (4) items or sub-menus:

- 2A: **Relay 1**
- 2B: **Relay 2**
- 2C: **SSR1** (Solid State Relay)
- 2D: **Output mA1** (Range 4÷20 mA)



**Note:** To set the relative function to each output, read the manual at the **Advanced Menu\Outputs Configuration** section (INDEX MENU 3H).

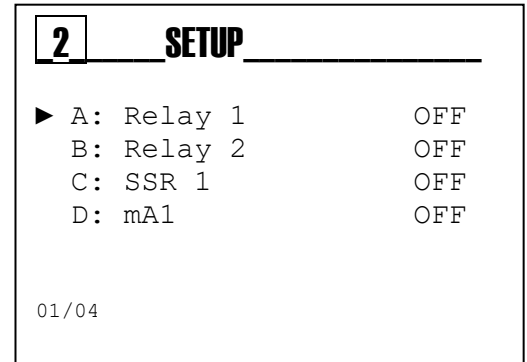

Below are illustrated the settings required for each sub-menu indicated above.

To exit the menu, press the **Esc** key; when at least one parameter has been changed, the instrument will display the question “save?”; confirm with the **Enter** key.

For not saving, select NO using the **(+)** or **(-)** key and confirm with the **Enter** key.

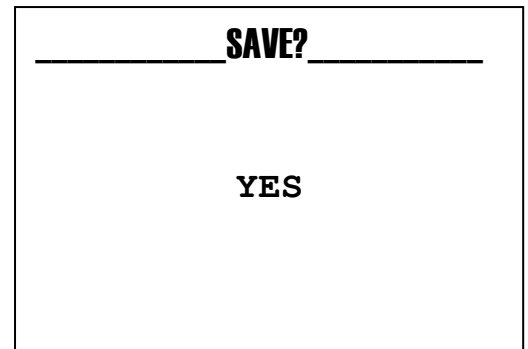

**Note:** Check the selected unit of measure (menu 3D1) and set the values in the setup menu within the ranges allowed by the probes used. Below is an example table for each standard cell constant:

Probe	Range
C 0.01 cm <sup>-1</sup> / K 100 sensor	0.005 $\mu$ S/cm to 200 $\mu$ S/cm (5 K $\Omega$ x cm to 200 M $\Omega$ x cm)
C 0.10 cm <sup>-1</sup> / K 10 sensor	0.05 $\mu$ S/cm to 2 mS/cm (500 $\Omega$ x cm to 20 M $\Omega$ x cm)
C 0.20 cm <sup>-1</sup> / K 5 sensor	0.1 $\mu$ S/cm to 4 mS/cm (250 $\Omega$ x cm to 10 M $\Omega$ x cm)
C 1.00 cm <sup>-1</sup> / K 1 sensor	0.5 $\mu$ S/cm to 20 mS/cm (50 $\Omega$ x cm to 2 M $\Omega$ x cm)
C 10.0 cm <sup>-1</sup> / K 0.1 sensor	5 $\mu$ S/cm to 200 mS/cm (5 $\Omega$ x cm to 200 K $\Omega$ x cm)
C 20.0 cm <sup>-1</sup> / K 0.5 sensor	10 $\mu$ S/cm to 400 mS/cm (2,5 $\Omega$ x cm to 100 K $\Omega$ x cm)
TDS Range	0.3 to 2.0 ppm/ $\mu$ S

DosingPump.ir

## SETUP MENU \ RELAY 1 (ONE) (INDEX MENU 2A)

Scroll through the menu using the **(+)** or **(-)** key, select the item Relay 1 and confirm with the **Enter** key.

Scroll through the menu using the **(+)** or **(-)** key, select the item and confirm with the **Enter** key.

The **Relay 1** can be set only for Chemical Measure, the **Relay 2** can be set either for Chemical Measure or for Temperature Measure with the following activation methods:

### ON/OFF Method

(Activation on threshold, with maintenance of the state)

2A1 **SetPoint**: Chemical value to maintain into the process

2A2 **Activation Type**: **Low** as the minimum value to maintain  
**High** as the maximum value to maintain

2A3 **Hysteresis**: Incremental or decremental value of the SetPoint

2A4 **Hysteresis Time**: Time activated on the hysteresis value

2A5 **Delay Start**: Delay time for relay activation

2A6 **Delay End**: Delay time for relay deactivation

2A7 **OFA**: Relay maximum activation time

2A8 **Over Range**: A value that is subtracted from and added to the SetPoint value and defines a measuring range of operation, outside of which the measure error message is displayed.



**Note**: See **ANNEX A** for a graphical example on using

### Timed Method

(Timed activation on threshold)

We have all the items described in the ON/OFF method.

In addition we have:

2A9 **Time On**: Relay closing time

2A10 **Time Off**: Wait time with the relay open



**Note**: See **ANNEX B** for a graphical example on using

### Proportional (PWM) Method

(Timed activation on proportional threshold)

We have all the items described in the ON/OFF method.

In addition we have:

2A9 **Interval**: Maximum time to modulate according to the measure

2A10 **Proportional Band**: A value that is subtracted from or added to the SetPoint value, within the range the instrument calculates the relay closing time proportional to the chemical measure according to the distance from the SetPoint.



**Note**: See **ANNEX C** for a graphical example on using

(\*The hysteresis time has no effect if the hysteresis value is not set on menu 2A3)

2 SETUP	
▶ A: Relay 1	OFF
B: Relay 2	OFF
C: SSR 1	OFF
D: mA1	OFF
01/04	

2A RELAY_1_ON/OFF	
▶ 1: SetPoint	720 $\mu$ S
2: Type	High
3: Hysteresis	0.00 $\mu$ S
4: Hyst. Time	00'00"
5: Delay Start	00'00"
6: Delay End	00'00"
7: OFA	OFF
8: Over Range	OFF
01/08	

2A RELAY_1_Timed	
7: OFA	OFF
8: Over Range	OFF
▶ 9: Time On	00'10"
10: Time Off	00'10"
01/10	

2A RELAY_1_PWM	
7: OFA	OFF
8: Over Range	OFF
▶ 9: Period	00'10"
10: Prop. Band	200 $\mu$ S
01/10	

## SETUP MENU \RELAY 2 (TWO) (INDIEX MENU 2B)

Scroll through the menu using the **(+)** or **(-)** key, select the item Relay 2 and confirm with the **Enter key**.

Scroll through the menu using the **(+)** or **(-)** key, select the item and confirm with the **Enter key**.

The Relay 2 (two) can be set for the Chemical Measure or Temperature as indicated in the Relay 1 menu (see the previous page); it is also possible to set the Wash and Alarm mode as follows:

### Wash Method

Activation of a washing system for the probe

2B1 **Wash Time**: Value in minutes and seconds for washing the probe.

2B2 **Delay Measure**: Value in minutes and seconds to wait for the stability of measure.

2B3 **Wait New Wash**: Value in hours and minutes of waiting for a new washing action.



**Note:** See **ANNEX D** for a graphical example on using

### Alarm Method

Remote repetition of the alarm through relay 2 (two). below is the list of the alarm events:

2B1 **Over Range R1**: chemical measure out of range Relay 1

2B2 **OFA R1**: Maximum dosing time expired

2B3 **Reed Alarm**: Alarm for the Reed sensor activation

2B4 **Temperature Probe Alarm**: Alarm for probe disconnected



**Note:** See **ANNEX E** for a graphical example on using

2 SETUP	
A: Relay 1	OFF
▶ B: Relay 2	OFF
C: SSR 1	OFF
D: mA1	OFF
01/04	

2B Relay_2_Wash	
▶ 1: Wash	00' 00"
2: Delay	00' 00"
3: Wait	OFF
01/03	

2B Relay_2 Alarms	
▶ 1: R1 OverRng	NO
2: R1 OFA	NO
3: Reed Alarm	NO
4: Temp. Alarm	NO
01/04	

## SETUP MENU \ SSR1 (INDEX MENU 2C)

Scroll through the menu using the **(+)** or **(-)** key, select the item **SSR1** and confirm with the **Enter** key.

Scroll through the menu using the **(+)** or **(-)** key, select the item and confirm with the **Enter** key.

The output SSR1 (one) is a solid state relay used as frequency output.

The output SSR1 can be set either for Chemical Measure or for Temperature Measure

### SSR1 Setup (INDEX MENU 2C)

2C1 **SetPoint**: Chemical value to maintain into the process

2C2 **Activation Type**:

**Low** as the minimum value to maintain

**High** as the maximum value to maintain

2C3 **Pulse Max**: Maximum value of pulses (range:20÷400)

2C4 **Pulse min**: Minimum value of pulses (range:1÷100)

2C5 **Proportional Band**: A value that is subtracted from or added to the SetPoint value, within the range the instrument calculates the number of pulses proportional to the chemical measure according to the distance from the SetPoint.

2 SETUP	
A: Relay 1	OFF
B: Relay 2	OFF
▶ C: SSR 1	OFF
D: mA1	OFF

01/04

2C SSR1	
▶ 1: SetPoint	740 $\mu$ S
2: Type	High
3: Pulse Max	400
4: Pulse min	1
5: Prop. Band	200 $\mu$ S

01/05



**Note:** See **ANNEX F** for a graphical example on using

(\* If the Pulse min value is greater than Pulse Max value, the output will have the Pulses min value)

## SETUP MENU \ OUTPUT MA1 (INDEX MENU 2D)

Scroll through the menu using the **(+)** or **(-)** key, select the item mA1 and confirm with the **Enter** key.

Scroll through the menu using the **(+)** or **(-)** key, select the item and confirm with the **Enter** key

The output mA1 (one) is a current output in mA (milliAmpere), in active configuration with the range 4÷20 mA.

The output **mA1** can be set either for Chemical Measure or for Temperature Measure.

### Output mA1 Setup (INDEX MENU 2D)

2D1 **Start mA**: Measure value associated to the 4 mA value

2D2 **End mA**: Measure value associated to the 20 mA value

2D3 **Hold**: Freezes the current value in case of Holding Alarm

2D4 **Namur**: Sets the current value to 3.6 mA or 22 mA in case of Alarm



**Note:** See **ANNEX G** for a graphical example on using

2 SETUP	
A: Relay 1	OFF
B: Relay 2	OFF
C: SSR 1	OFF
▶ D: mA1	OFF

01/04

2D Output_mA1	
▶ 1: Start mA	0,5µS
2: End mA	20000µS
3: Keep	NO
4: Namur	OFF

01/04

## ADVANCED MENU (INDEX MENU 3)

Use the **MODE** key to scroll through the icons on the status bar, from left to right, select the **adv** menu and confirm with the **Enter** key.

The **Advanced** menu consists of thirteen (13) items or sub-menus, as follows:

- A: **Language**
- B: **Password**
- C: **Display**
- D: **Chemical Measure**
- E: **Temperature Measure**
- F: **Cell Constant**
- G: **Alarms Configuration**
- H: **Outputs Configuration**
- I: **Control Panel**
- L: **Statistics**
- M: **System Reset**
- N: **Firmware Revision**

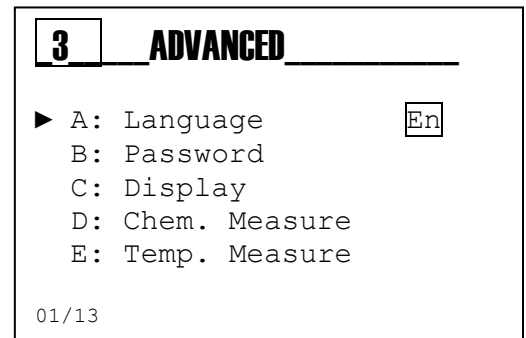
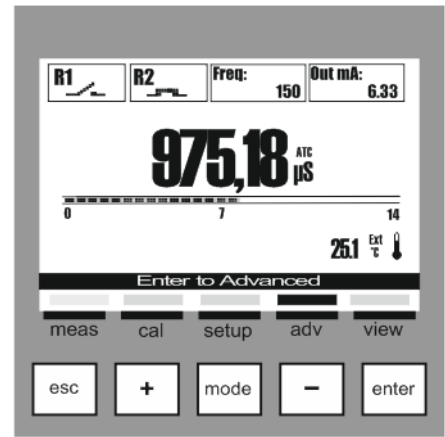

Below are illustrated the settings required for each sub-menu indicated above.

To exit the menu, press the **Esc** key; when the parameters have been changed, the instrument will display the question "save?"; confirm with the **Enter** key.



For not saving, select NO using the (+) or (-) key and confirm with the **Enter** key.

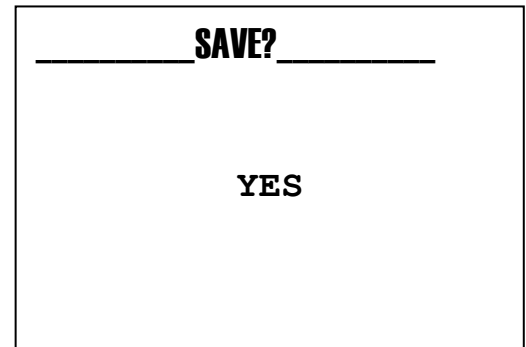



## ADVANCED MENU \ LANGUAGE (INDEX MENU 3A)

The menu consists of five (5) items that allow to select the dialog language for the instrument's menus and messages.

Scroll through the menu using the **(+)** or **(-)** key, select the item Language and confirm with the **Enter** key.

Scroll through the menu using the **(+)** or **(-)** key, select the item and confirm with the **Enter** key.

The instrument automatically changes the language of the menu and returns to the previous level, menu 3.

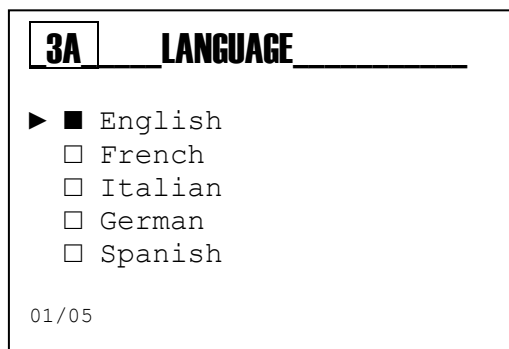
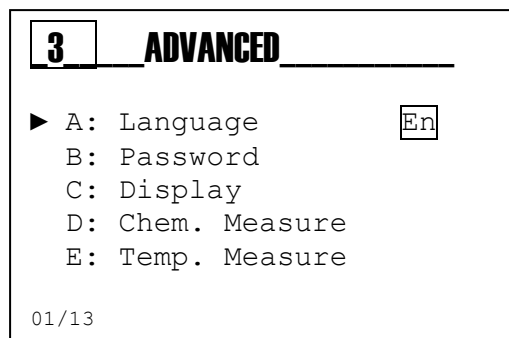

## ADVANCED MENU \ PASSWORD (INDEX MENU 3B)

The menu consists of three (3) items that allows to select the menu protection Password and enable the Calibration menu or the Setup menu.

Scroll through the menu using the **(+)** or **(-)** key, select the item and confirm with the **Enter** key.

### Password Function

3B1 **Set Password**: set the numeric value

**Note:** If the password is present it will be displayed

Example: "Old Password 1234"

3B2 **Calibration Menu**: Enable or Disable the Calibration menu

3B3 **Setup Menu**: Enable or Disable the Setup menu

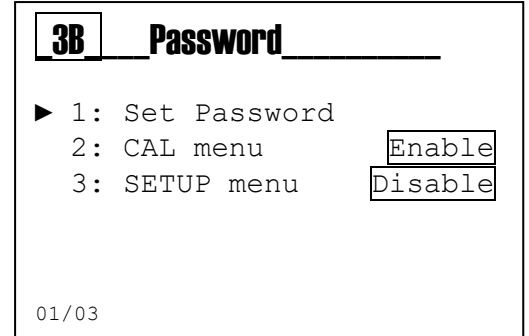
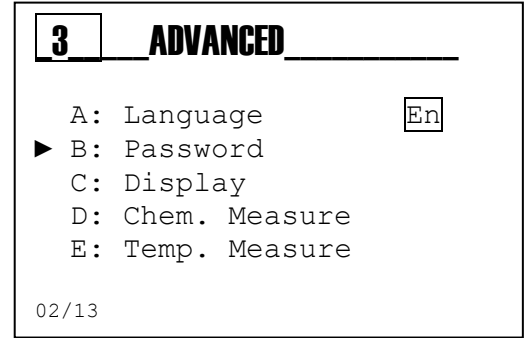

**Note:** To remove the password set four zeros (0000) and confirm with the **Enter** key.

The following are examples of the sub-menus shown above.



### Menu 3B1

Set the value for password, other than 0000 using **(+)** and **(-)** keys and move to the right using the **Mode** key.



### Menu 3B2

YES= Menu Enabled

NO= Menu Disabled; can be accessed by entering the password

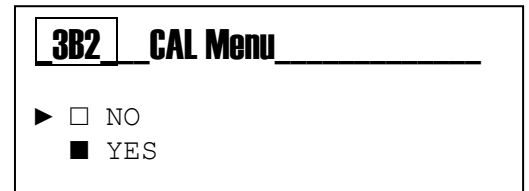

### Menu 3B3

YES= Menu Enabled

NO= Menu Disabled; can be accessed by entering the password

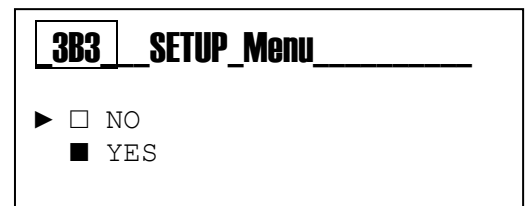

DosingPump.ir

## ADVANCED MENU \ DISPLAY (INDEX MENU 3C)

The menu consists of five (5) items that allow to select Contrast, Mode, ON, ECO, Reverse.

Scroll through the menu using the **(+)** or **(-)** key, select the item and confirm with the **Enter** key.

### Display Function:

3C1 **Contrast:** Balance value between the menu writings and the background brightness

3C2 **Mode:** Turned on, Turned off, "ECO" Adjustment

3C3 **On:** Light value function always on

3C4 **ECO:** Light value function of electronic regulation

3C5 **Reverse:** Inverted display, white writings on black background.

The following are examples of the sub-menus shown above.

#### Menu 3C1

Adjusts the background brightness

#### Menu 3C2

Select the Backlight function:

OFF= Turned off; ON= Turned on; ECO= Fade

#### Menu 3C3

Select the brightness value for ON mode

#### Menu 3C4

Select the brightness value for ECO mode

#### Menu 3C5

Invert the writings on the display to obtain a high contrast

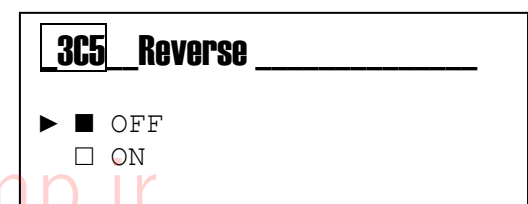
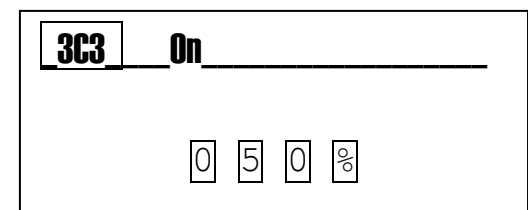
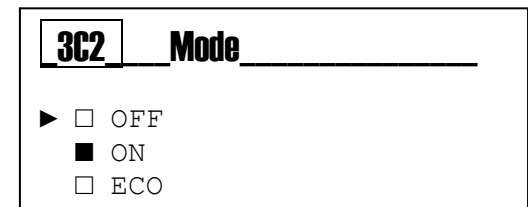
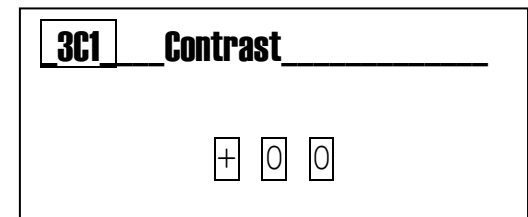
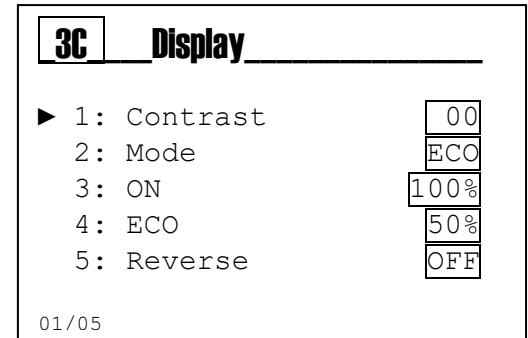
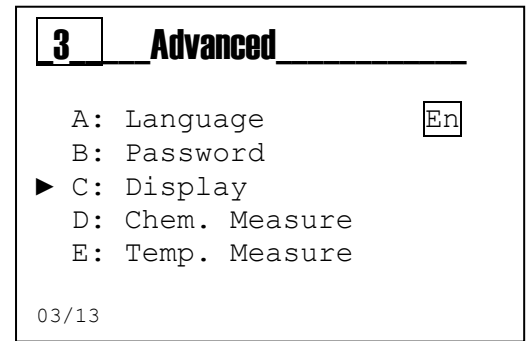

DosingPump.ir

## ADVANCED MENU \ CHEMICAL MEASURE (INDEX MENU 3D)

The menu consists of five (5) items that allow to select Measure Unit, Temperature Compensation, Measure Filter, TDS and Decimal Point.

Scroll through the menu using the **(+)** or **(-)** key, select the item and confirm with the **Enter** key.

### Chemical Measure Function (INDEX MENU 3D)

3D1 **Measure Unit**: Select the measure unit for Conductivity.

3D2 **Temperature Compensation**: The measure is compensated for temperature:

- **OTC**= Compensation disabled.
- **MTC**= Manual, with a fixed value manually set.
- **ATC**= Automatic, with temperature sensor.

**Note:** To set the value manually, access the menu 3E2 Temp. Meas.

3D3 **Measure Filter**: The measure is filtered with arithmetic mean.

- **Low**= arithmetic means every 4 seconds
- **Medium**= arithmetic means every 8 seconds
- **High**= arithmetic means every 16 seconds

3D4 **TDS**: Total Dissolved Solids, the conductivity can be used as an indicator of the amount of material dissolved in a solution. It is expressed in ppm/ $\mu$ S.

3D5 **Decimal Point**: set the position of the decimal point for the measure.

The following are examples of the sub-menus shown above.

#### Menu 3D1

Select the measure unit for Conductivity.

**Note:**

- The change of measure unit provides a parameter reset with the default values.
- The units of measure PPM (parts per million) and PPB (parts per billion) can be used by setting the TDS value (menu 3D4).

#### Menu 3D2

Select the temperature compensation of the chemical measure.

**OTC**= Function disabled

**MTC**= Temperature compensation with a Manual value, see menu 3E

**ATC**= Temperature compensation with an Automatic value, see menu 3E

#### Menu 3D3

The measure is filtered with arithmetic mean.

- **Low**= arithmetic mean every 4 seconds
- **Medium**= arithmetic mean every 8 seconds
- **High**= arithmetic mean every 16 seconds

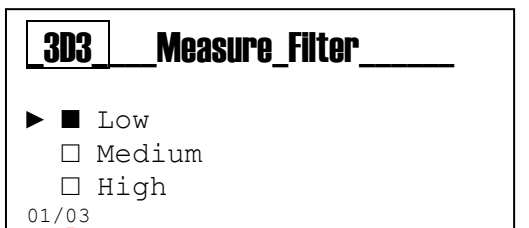
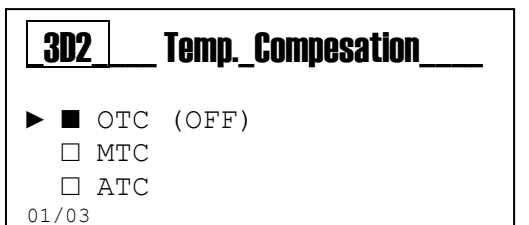
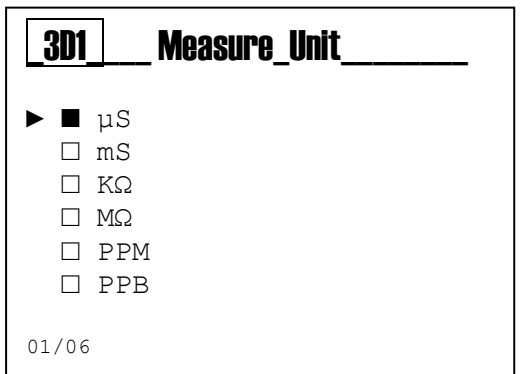
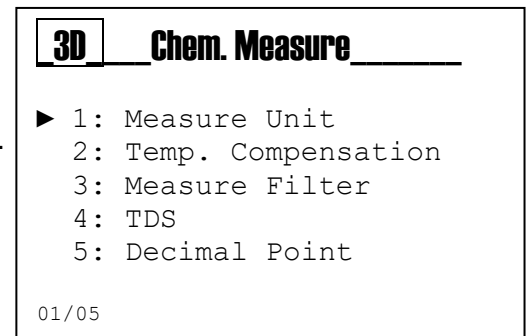
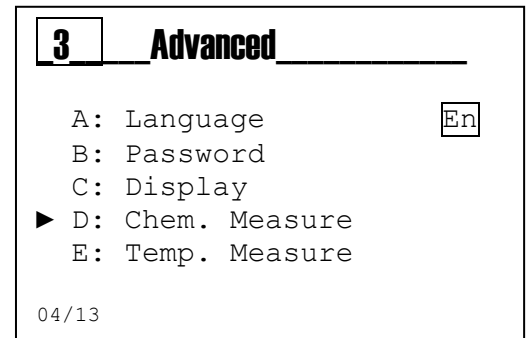

DosingPump.ir

### Menu 3D4 TDS Total Dissolved Solids

To view the conductivity measure in Total Dissolved Solids you must set a conversion factor between 0.3 and 2. The measure will be converted to PPM or PPB per  $\mu\text{S}$ .

The typical TDS value in water is 0.7 and it is given by the subtraction of **Total Suspended Solids (TSS)** from the **Total Solids (TS)**

Below is a calculation example:

#### Total Solids (TS)

All the materials dissolved and suspended in a natural or drained water are indicated as total solids. The determination of the total solids is performed by evaporating the water from the sample into a thermostated oven at  $105^{\circ}\text{C}$ .

The Total Solids content is given by:

**Total Solids (mg/L) =  $(M1 - M0) \times 1000 / V\text{Probe}$**  where:

**M1**= mass in mg of the capsule and residual material after evaporation;

**M0**= mass in mg of the empty capsule;

**VProbe** = volume in mL of analyzed sample.

Example:

$$\begin{aligned}M1 &= 10023,6 \text{ mg} \\M0 &= 10000 \text{ mg} \\V\text{Probe} &= 100 \text{ mL} \\10023,6 - 10000 &= 23,6 \text{ mg} \\23,6 \times 1000 / 100 &= 236 \text{ mg/L}\end{aligned}$$

**Total Suspended Solids (TSS)** represent that part of material suspended in a water sample which can be separated by filtration through a membrane filter with a porosity of  $0.45 \mu\text{m}$  (micrometer  $\mu\text{m}$ ).

The solids collected on the filter are dried at a temperature of  $103\text{-}105^{\circ}\text{C}$  until a constant weight.

The Total Suspended Solids content is given by:

Suspended Solids (mg/L)=  **$(M1 - M0) \times 1000 / V\text{Probe}$**  where:

**M1**= mass in mg of the capsule+filter and residual material after evaporation;

**M0**= mass in mg of the capsule+filter;

**VProbe**= volume in mL of filtered sample.

### Menu 3D5

Set the position of the decimal point for the measure to highlight the decimal value.

Scroll through the menu using the **(+)** or **(-)** key, select the item and confirm with the **Enter** key.

<b>3D5</b>	<b>Decimal Point</b>	_____
▶	<input checked="" type="checkbox"/>	XXXXX,
	<input type="checkbox"/>	XXXX, X
	<input type="checkbox"/>	XXX, XX
	<input type="checkbox"/>	XX, XXX
	<input type="checkbox"/>	X, XXXX
01/05		

## ADVANCED MENU \ TEMPERATURE MEASURE (INDEX MENU 3E)

Scroll through the menu using the **(+)** or **(-)** key, select the item and confirm with the **Enter** key.

### Temperature Measure Function (INDEX MENU 3E)

**3E1 Select:** PT100 or PT1000 temperature sensor connected or using a manual temperature value.

**3E2 Measure Unit:** Set Celsius (°C) or Fahrenheit (°F) unit

**3E3 Manual Value:** Set the temperature value without PT100 or PT1000 temperature sensor.

**3E4 Filter:** The measure is filtered with arithmetic mean.

- **Low**= arithmetic mean every 4 seconds
- **Medium**= arithmetic mean every 8 seconds
- **High**= arithmetic mean every 16 seconds

**3E5 Compensation Type:** Set the compensation method:

- Ultra-Pure Water (H<sub>2</sub>O)
- Linear to 25°C
- Linear to 20°C

**3E6 Linear Coefficient:** set the increment percentage (SLOPE) used in the linear compensation.

The following are examples of the sub-menus shown above.

#### Menu 3E1

Select between manual temperature value function and external temperature measure through PT100 or PT1000 temperature sensor.

#### Menu 3E2

Select the measure unit.

#### Menu 3E3

Set the temperature value as manual value.

#### Menu 3E4

The measure is filtered with arithmetic mean.

- **Low**= arithmetic mean every 4 seconds
- **Medium**= arithmetic mean every 8 seconds
- **High**= arithmetic mean every 16 seconds

**3**
**Advanced**

---

A: Language En

B: Password

C: Display

D: Chem. Measure

▶ E: Temp. Measure

05/13

**3E**
**Temp. Measure**

---

▶ 1: Selection Manual

2: Unit Meas. °C

3: Manual 25°C

4: Filter Medium

5: Comp. Type Lin20°C

6: Lin. Coeff. 2,00%/°C

01/06

**3E1**
**Selection**

---

▶  Manual

External

01/02

**3E2**
**Unit Meas.**

---

▶  °C

°F

01/02

**3E3**
**Manual**

---

27.0

°C

7	8	9
4	5	6
1	2	3
0	.	

?  
+/-  
Canc  
Enter

**3E4**
**Filter**

---

▶  Low

Medium

High

01/03

DosingPump.ir

**Menu 3E5 Compensation Type:** Set the compensation method for the measure

- Ultra-Pure Water (H<sub>2</sub>O)
  - Select this item for conductivity measures in ultra-pure water or lower than 0.2 μS (from 5MΩ to 18MΩ). The compensation function is in compliance with ASTM D1125 and D5391 standard.
- Linear to 25°C
  - Select this item for conductivity measures greater than 0.2 μS (lower than 5MΩ). The measure compensation is linear, referred to the temperate of 25°C. The compensation function requires the use of the **linear coefficient** menu 3E6.
- Linear to 20°C
  - Select this item for conductivity measures greater than 0.2 μS (lower than 5MΩ). The measure compensation is linear, referred to the temperate of 20°C. The compensation function requires the use of the **linear coefficient** menu 3E6.

### Menu 3E6 Linear Coefficient

Select the temperature coefficient according to the solution to be measured, typical indications are:

- Water with neutral pH value (7 pH) = 2,00%/°C
- Alkaline solution, pH value greater than 7 pH= 1,9%/°C
- Acidic solution, pH value lower than 7 pH= 1,8%/°C

To determine the Linear Coefficient value, proceed as follows:

Obtain a container and an electric or gas stove.

Connect the PT100/PT1000 sensor to the K100 instrument or obtain a thermometer.

Place the sample solution in the container.

**Note:** This method is valid only for conductivity greater than 84μS.

Set the temperature compensation function to OTC (menu 3D2)

Take a measure of the sample at room temperature and record the conductivity and temperature value.

*Example:*

$$\begin{aligned}C' &= 200\mu\text{S} \\ T' &= 23^\circ\text{C}\end{aligned}$$

Heat the sample and increasing its temperature to 50°C.

**Note:** Wait for the temperature change to slow down and stabilize.

Take a second measure of conductivity (C'') and temperature (T'').

*Example:*

$$\begin{aligned}C'' &= 600\mu\text{S} \\ T'' &= 50^\circ\text{C}\end{aligned}$$

To calculate the Linear Coefficient for 25°C complete the following function:

$$\text{Linear Coefficient} = 100 \cdot (C'' - C') / (C'' \cdot (T'' - 25^\circ\text{C})) - (C' \cdot (T' - 25^\circ\text{C}))$$

$$\text{Linear Coefficient} = 100 \cdot (600\mu\text{S} - 200\mu\text{S}) / (600\mu\text{S} \cdot (50^\circ\text{C} - 25^\circ\text{C})) - (200\mu\text{S} \cdot (23^\circ\text{C} - 25^\circ\text{C}))$$

$$\text{Linear Coefficient for } 25^\circ\text{C} = 2.59\%/^\circ\text{C}$$

DosingPump.ir

## ADVANCED MENU \ CELL CONSTANT (INDEX MENU 3F)

Scroll through the menu using the **(+)** or **(-)** key, select the item and confirm with the **Enter** key.

### Cell Constant Function (INDEX MENU 3F)

**3F1 Type:** Select Standard or Custom

**3F2 Standard:** List of cell constant values for standard measure.

**3F3 Custom:** Adjustable cell constant value for custom measure.

**3F4 Actual:** View the cell constant in use.

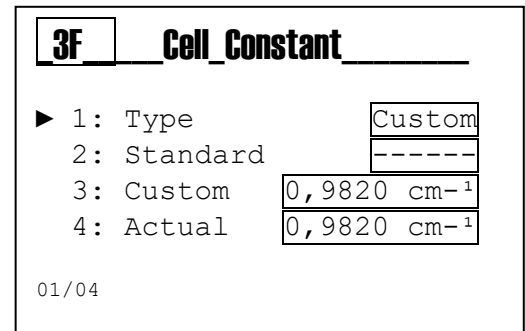
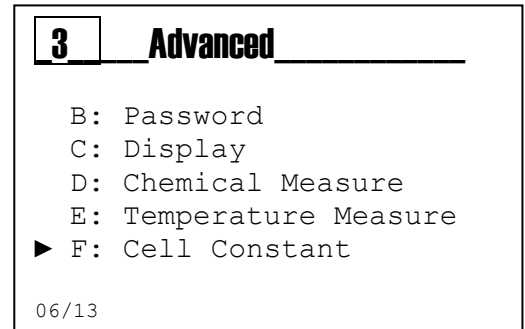

The following are examples of the sub-menus shown above.

#### Menu 3F1 Probe Type

Select the type of probe used, standard or custom;  
Set the used value by accessing the menu 3F2 or 3F3.

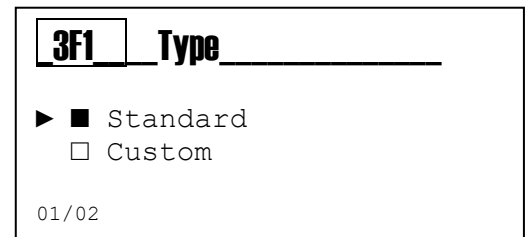

#### Menu 3F2 Standard

Set the measure cell constant by selecting it from the list.

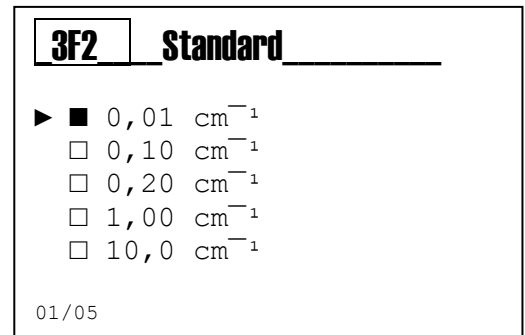

#### Menu 3F3 Custom

Set manually the measure cell constant by editing the value.

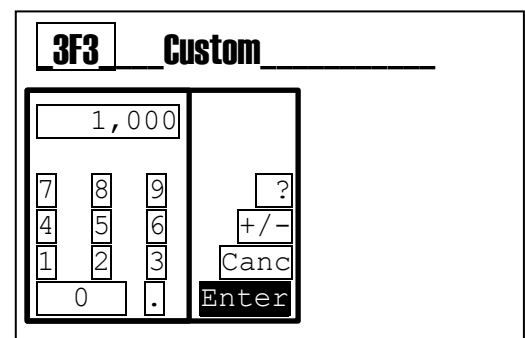

#### Menu 3F4 Actual

The instrument displays the set value or the value calculated during the calibration.

DosingPump.ir



## ADVANCED MENU \ ALARMS CONFIGURATION (INDEX MENU 3G)

Scroll through the menu using the **(+)** or **(-)** key, select the item and confirm with the **Enter** key.

### Alarms Configuration Function

**3G1 Reed Logic:** Set the sensor logic

- Reed NO (Normally Open)
- Reed NC (Normally Close)

**3G2 Delay Reed:** Set the delay time for alarm activation to change REED status

**3G3 Instrument blocking:** Enables instrument blocking in case of alarm. The outputs are automatically set on the programmed alarm state.

**3G4 Temp. Probe Alarm:** Enables a visual alarm or a instrument block in case the temperature probe is broken or disconnected.

<b>3</b>	<b>Advanced</b>
C: Display	
D: Chem. Measure	
E: Temp. Measure	
F: Cell Constant	
▶ G: Alarm Setting	
07/13	

<b>3G</b>	<b>Alarm_Setting</b>
▶ 1: Reed Logic	<input type="checkbox"/> NO
2: Reed Delay	00'00"
3: Block	<input type="checkbox"/> NO
4: Alarm Temp.	Notify
01/04	

## ADVANCED MENU \ OUTPUTS CONFIGURATION (INDEX MENU 3H)

Scroll through the menu using the (+) or (-) key, select the item and confirm with the **Enter** key.

### Outputs Configuration Function

**3H1 Relay 1:** Disabled, On/OFF (threshold), Timed, Proportional PWM, for Chemical Measure

**3H2 Relay 2:** Disabled, On/OFF (threshold), Timed, Proportional PWM, either for Chemical Measure or for Temperature Measure, and also Probe Wash and Remote Alarm

**3H3 SSR 1:** Disabled, Chemical Measure, Temperature Measure

**3H4 mA 1:** Disabled, Chemical Measure, Temperature Measure

**3**
**Advanced**

D: Chem. Measure  
 E: Temp. Measure  
 F: Cell Constant  
 G: Alarm Setting  
 ▶ H: Output Setting

08/13

**3H**
**Output Setting**

▶ 1: Relay 1 OFF  
 2: Relay 2 OFF  
 3: SSR 1 OFF  
 4: mA 1 OFF

01/04



**Note:** On the Setup menu (INDEX MENU 2) it is possible to set the parameters for each selected function.

**3H1**
**Relay\_1**

▶  OFF  
 On/OFF Measure  
 Timed Measure  
 PWM Measure

01/04

**3H2**
**Relay\_2**

▶  OFF  
 On/OFF Measure  
 Timed Measure  
 PWM Measure  
 On/OFF Temp.  
 Timed Temp.  
 PWM Temp.  
 Probe Wash  
 Alarm

01/09

**3H3**
**SSR\_1**

▶  OFF  
 Measure  
 Temperature

01/03

**3H4**
**mA\_1**

▶  OFF  
 Measure  
 Temperature

01/03

## ADVANCED MENU \ CONTROL PANEL (INDEX MENU 3I)

### Menu 3I Control Panel

Scroll through the menu using the **(+)** or **(-)** key, select the item and confirm with the **Enter** key.

- 311 Chemical Measure: Displays the unfiltered measure in KΩ.
- 312 Temp. Measure: Displays the unfiltered measure in °C/°F
- 313 Test Relay 1: Manual closing of the relay contact
- 314 Test Relay 2: Manual closing of the relay contact
- 315 Simulation Frequency 1: Simulates an output value
- 316 Simulation Current Output 1: Simulates an output value
- 317 Displays the Reed Input status



**Note:** The instrument allows the simultaneously simulation of multiple outputs, all the set values will be cleared on exiting the menu **3I Control Panel**.

**3**
**Advanced**

F: Cell Constant  
 G: Alarms Setting  
 H: Outputs Setting  
 ► I: Control Panel

09/12

**3I**
**Control\_Panel**

► 1: Chemical Measure  
 2: Temp. Measure  
 3: Sim. Relay 1  
 4: Sim. Relay 2  
 5: Sim. Freq. 1  
 6: Sim. Out mA 1  
 7: Reed Input

01/07

## ADVANCED MENU \ STATISTICS (INDEX MENU 3L)

### Menu 3L Statistics

Scroll through the menu using the **(+)** or **(-)** key, select the item and confirm with the **Enter** key.

- 3L1 Number of registered Startups
- 3L2 Number of registered Alarms
- 3L3 Number of activations Relay 1
- 3L4 Number of activations Relay 2
- 3L5 Number of activations Reed
- 3L6 Reset all values recorded in the statistics menu

**3**
**Advanced**

G: Alarm Setting  
 H: Outputs Setting  
 I: Control Panel  
 ► L: Statistics

10/12

**3L**
**Statistics**

► 1: Power on 0  
 2: Alarms 0  
 3: RL 1 Act. 0  
 4: RL 2 Act. 0  
 5: Reed Act. 0  
 6: Reset Statistics

01/06

DosingPump.ir

## ADVANCED MENU \ RESET INSTRUMENT (INDEX MENU 3M)



### Menu 3M System Reset

The instrument allows to delete all the parameters and restore the default values.

**3**

**Advanced**

H: Output Setting  
I: Control Panel  
L: Statistics  
▶ M: Reset Instrument

11/12

**3M**

**System\_Reset**

Are you sure?

**NO**  
YES

## ADVANCED MENU \ FIRMWARE REVISION (INDEX MENU 3N)

### Menu 3N Firmware Revision

The instrument displays the Firmware code and revision of the device.

**3**

**Advanced**

I: Control Panel  
L: Statistics  
M: System Reset  
▶ N: Fw Revision

12/12

**3N**

**Fw\_Revision**

Firmware Code  
0000529XXX

Fw Revision  
X.X

DosingPump.ir

## VIEW MENU (INDEX MENU 4)

Use the **MODE** key to scroll through the icons on the status bar, from left to right, select the **view** menu and confirm with the **Enter** key.

The **Preview Menu** consists of 3 views

Scroll through the menu using the **(+)** or **(-)** key, select the item and confirm with the **Enter** key.

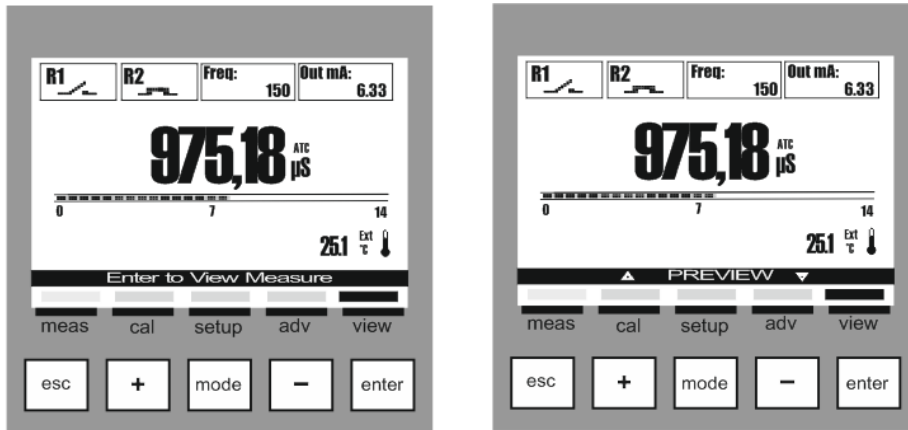

### Views Table

<p>Preview 1/3 Complete</p>	<p>Preview 2/3 Two Big Measures</p>	<p>Preview 3/3 One Big Measure</p>
---------------------------------	---	--

## GENERAL SPECIFICATIONS

<b>Conductivity/Resistance Specifications</b>	
Range with C 0.01 cm <sup>-1</sup> / K 100 sensor	0.005 µS/cm to 200 µS/cm (5 KΩ x cm to 200 MΩ x cm)
Range with C 0.10 cm <sup>-1</sup> / K 10 sensor	0.05 µS/cm to 2 mS/cm (500 Ω x cm to 20 MΩ x cm)
Range with C 0.20 cm <sup>-1</sup> / K 5 sensor	0.1 µS/cm to 4 mS/cm (250 Ω x cm to 10 MΩ x cm)
Range with C 1.00 cm <sup>-1</sup> / K 1 sensor	0.5 µS/cm to 20 mS/cm (50 Ω x cm to 2 MΩ x cm)
Range with C 10.0 cm <sup>-1</sup> / K 0.1 sensor	5 µS/cm to 200 mS/cm (5 Ω x cm to 200 KΩ x cm)
Range with C 20.0 cm <sup>-1</sup> / K 0.5 sensor	10 µS/cm to 400 mS/cm (2,5 Ω x cm to 100 KΩ x cm)
Resolution Cond/Res	0.0001 / 0.001 / 0.01 / 0.1 / 1 (adjustable from menu)
Accuracy Cond/Res	± 5% on the measuring point
Maximum distance of the sensor	up to 50 m (up to 164 ft)
TDS Range	0.3 to 2.0 ppm/µS
<b>Pt100/ Pt1000 Specifications</b>	
Temperature Input	Pt100/Pt1000
Pt100/Pt1000 Detection	Automatic
Error Condition	Automatic detection of disconnected/damaged probe
Driving Current	1 mA
Temperature Measure Range	0.0 to 100.0 °C (32.0 to 212.0 °F)
Sensor Maximum Distance	10 to 20 m (33 to 65 ft) depending on sensor
Temperature Resolution	0.1°C (°F)
Temperature Accuracy	± 1.0°C (± 1.8 °F)

## MECHANICAL SPECIFICATIONS FOR VERSION 1/4DIN

Dimensions (chassis – A x L x P)*	92 x 92 x 57,3 mm
Front Bezel – (A x L)	96 x 96 mm
Max. Depth	42 mm
Weight	310 g (0,68 lb)
Material	ABS/polycarbonate
Protection	IP 65 (front)/IP 20 (chassis)
Relative Humidity	0 to 95% non-condensing

\* L = Width, A = Height, P = Depth

## MECHANICAL SPECIFICATIONS FOR VERSION 1/2DIN

Dimensions (chassis – A x L x P)*	144 x 144 x 122.5 mm
Front Bezel – (A x L)	144 x 144 mm
Weight	735 g (1.62 lb)
Material	ABS/polycarbonate
Protection	IP 65
Relative Humidity	0 to 100% condensing

\* L = Width, A = Height, P = Depth

## ENVIRONMENTAL SPECIFICATIONS FOR VERSION 1/2DIN & 1/4DIN

Storage Temperature	- 25 to 65 °C (- 13 to 149 °F)
Environmental temperature range of operation	-10 to 50 °C (14 to 122 °F)
Emissions	According to EN55011 Class A specifications

DosingPump.ir

## ELECTRICAL SPECIFICATIONS

<b>Power Supply</b>	
Electrical Requirements	24, 115 or 230 VAC, 2.5VA
Frequency	50 or 60 Hz
Power Supply Fuse	500 mA delay not recoverable
<b>Power Supply (version 100÷240 VCA)</b>	
Electrical requirements	from 100 to 240 VAC ±10%, 5 W
Frequency	50 to 60 Hz
Power Supply Fuse	500 mA delay not recoverable
<b>Relay Outputs</b>	
RL1 and RL2	2-SPST mechanical 250 VAC/5A, 30 VCC/3 A
Relay RL1 Configuration	Load Activation
Relay RL2 Configuration	Load Activation, Probe Wash, Alarm Repetition
Cycle time	1sec to 3600sec
Delay time	1sec to 3600sec
Test Mode	ON, OFF
<b>SSR Output (Solid State Relays)</b>	
SSR1	2-SPST 60 VAC, max 100 mA, Bidirectional, NPN, PNP
Resistance in ON State	3 ohm @ 100mA
Leakage Current in OFF State	4 nA max
SSR1 and SSR2 Configuration	Pulse output
Frequency Range	0 to 400 imp/min
Pulse Duration	100 msec
Test Mode	0 to 400 imp/min
<b>Outputs 4÷20 mA</b>	
Analog Output Signals	1 output 4÷20 mA, galvanically isolated from the power supply.
Measure Error	+/- 0,05 mA
Load	max. 500 Ω
Error Condition	NAMUR: OFF, 3.6 mA, 22 mA
Test Mode	3 to 23 mA
<b>Digital Inputs</b>	
REED Digital Input	Input for dry contact 5 VCC, max 6 mA
<b>User Interface</b>	
Connection Terminals	Removable screw terminals AWG 14 < 2.5 mm <sup>2</sup>
Machine Cycle Time	ca. 1 s
Keyboard	5 tactile feedback keys
Display	Graphic LCD 128x128 pixels, Transflective, Backlit
Display Refresh	500 msec
Backlight	White, with energy saving function

\* DO NOT exceed the maximum allowable current limit, RISK of damaging the apparatus

DosingPump.ir

## ANNEX A: ON/OFF RELAY SETUP

Below is an example of settings for the Relay 1 or 2 to adjust the Conductivity using the pulse/pause method (on/off).

Example:

2A RELAY_1_ON/OFF	
1: SetPoint	720 $\mu$ S
2: Type	High
3: Hysteresis	0.00 $\mu$ S
4: Hyst. Time	00'00"
5: Delay Start	00'00"
6: Delay End	00'00"
7: OFA	OFF
8: Over Range	200 $\mu$ S

01/08

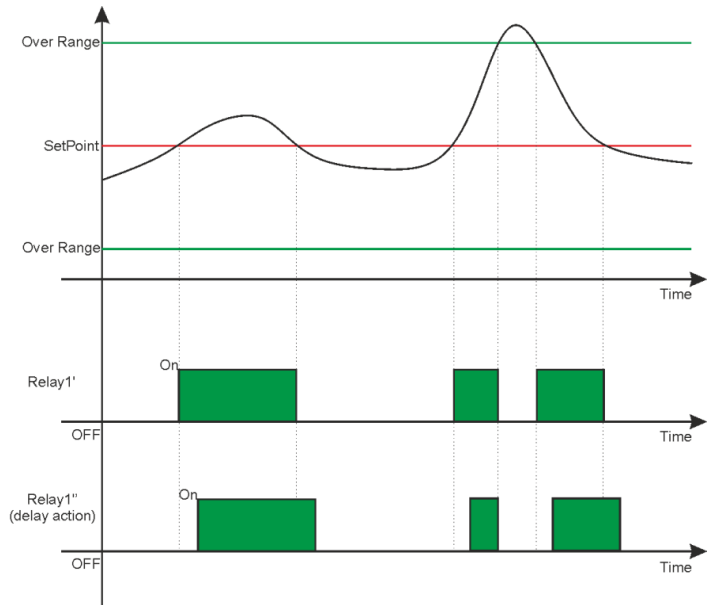

### Note:



- **Relay Activation:** When the measure (black line) exceeds the SetPoint the relay is activated and this status is maintained until the measure decreases at the SetPoint value (see relay 1').
- **Delay Activation:** By setting the menu items "5" and "6" the relay activation will be delayed equal to the set time (see relay 1").
- **Chemical Measure out of range:** When the measure (black line) exceeds the maximum or minimum Over Range value (green line), the system displays a visual alarm and blocks the dosage by changing the status of the relay 1 or 2.

**Low Function:** By setting the menu item "2" with the variable Low the relays activations are inverted compared to the above diagram.

**Hysteresis Function:** By setting the menu items "3" and "4" the instrument maintains the relay activation status both for the chemical measure value and for the time.

DosingPump.ir



## ANNEX A: ON/OFF RELAY SETUP WITH OFA FUNCTION

Below is an example of settings for the Relay 1 or 2 to adjust the Conductivity using the pulse/pause method (on/off) with OFA timers and Permanence Measure.

2A RELAY_1_ON/OFF	
1: SetPoint	720 $\mu$ S
2: Type	High
3: Hysteresis	0.00 $\mu$ S
4: Hyst. Time	00'00"
5: Delay Start	00'00"
6: Delay End	00'00"
7: OFA	00h 10m
8: Over Range	200 $\mu$ S

01/08

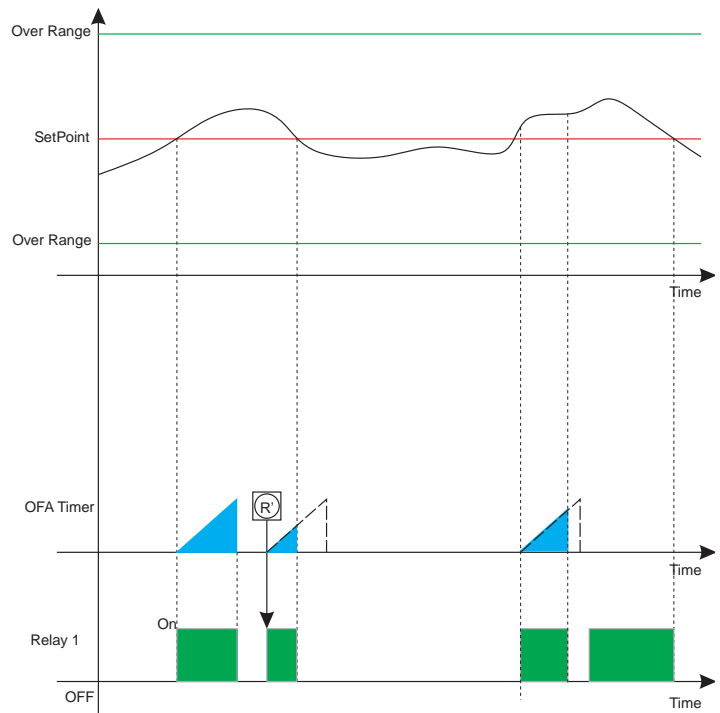

All the settings described on the previous page remain valid.

### Note:



- OFA (Over Feed Alarm):** By setting the function "7" OFA with a time in hours and minutes a control timer is activated in parallel to the relay activation. The function checks the activated relay persistence times and generates a visual prealarm at 70% of set value and a blocking alarm (R') at the end of the set time (100%). A manual intervention will be required to remove the blocking with the reset of the OFA function on the alarms menu (see alarms section).

## ANNEX B: TIMED RELAY SETUP

Below is an example of settings for the Relay 1 or 2 to adjust the Conductivity using the timed method.

2A RELAY_1 Timed	
1: SetPoint	720 $\mu$ S
2: Type	High
3: Hysteresis	0.00 $\mu$ S
4: Hyst. Time	00'00"
5: Delay Start	00'00"
6: Delay End	00'00"
7: OFA	OFF
8: Over Range	200 $\mu$ S
9: Time On	01'00"
10: Time Off	01'00"

01/10

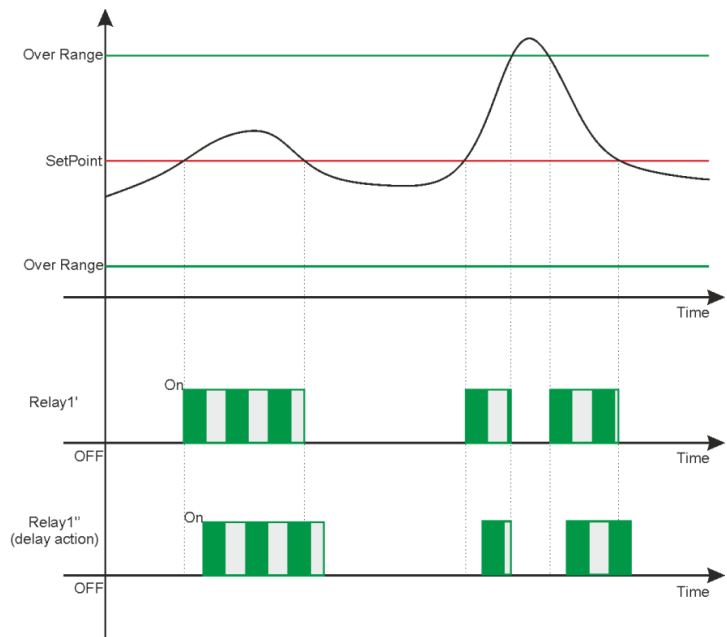

### Note:



- **Relay Activation:** When the measure (black line) exceeds the SetPoint the relay is activated and the times On and Off are executed as set on the menu items "10" and "11"; this status is maintained until the measure decreases at the SetPoint value (see relay 1').
- **Delay Activation:** By setting the menu items "5" and "6" the relay activation will be delayed equal to the set time (see relay 1")
- **Chemical Measure out of range:** When the measure (black line) exceeds the maximum or minimum Over Range value (green line), the system displays a visual alarm and blocks the dosage by changing the status of the relay 1 or 2.

**Low Function:** By setting the menu item "2" with the variable Low the relays activations are inverted compared to the above diagram.

**Hysteresis Function:** By setting the menu items "3" and "4" the instrument maintains the relay activation status both for the chemical measure value and for the time.

DosingPump.ir

## ANNEX B: TIMED RELAY SETUP WITH OFA FUNCTION.

Below is an example of settings for the Relay 1 or 2 to adjust the Conductivity using the timed method with OFA timers .

2A RELAY_1_Timed	
1: SetPoint	720 $\mu$ S
2: Activ. Type	High
3: Hysteresis	0.00 $\mu$ S
4: Hyst. Time	00'00"
5: Delay Start	00'00"
6: Delay End	00'00"
7: OFA	OFF
8: Over Range	200 $\mu$ S
9: Time On	01' 00"
10: Time Off	01' 00"

01/10

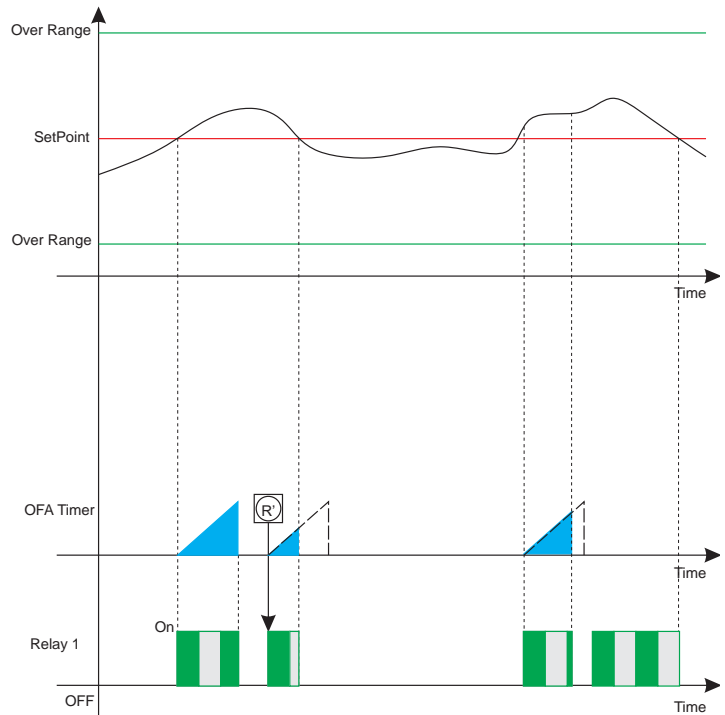

All the settings described on the previous page remain valid.

### Note:



- OFA (Over Feed Alarm):** By setting the function "7" OFA with a time in hours and minutes a control timer is activated in parallel to the relay activation. The function checks the activated relay persistence times and generates a visual prealarm at 70% of set value and a blocking alarm (R') at the end of the set time (100%). A manual intervention will be required to remove the blocking with the reset of the OFA function on the alarms menu (see alarms section).

## ANNEX C: PROPORTIONAL (PWM) RELAY SETUP

Below is an example of settings for the Relay 1 or 2 to adjust the Conductivity using the proportional (PWM) method.

2A RELAY_1_PWM	
1: SetPoint	720 $\mu$ S
2: Type	High
3: Hysteresis	0.00 $\mu$ S
4: Hyst. Time	00' 00"
5: Delay Start	00' 00"
6: Delay End	00' 00"
7: OFA	OFF
8: Over Range	200 $\mu$ S
9: Interval	02' 00"
10: Prop. Band	100 $\mu$ S

01/10

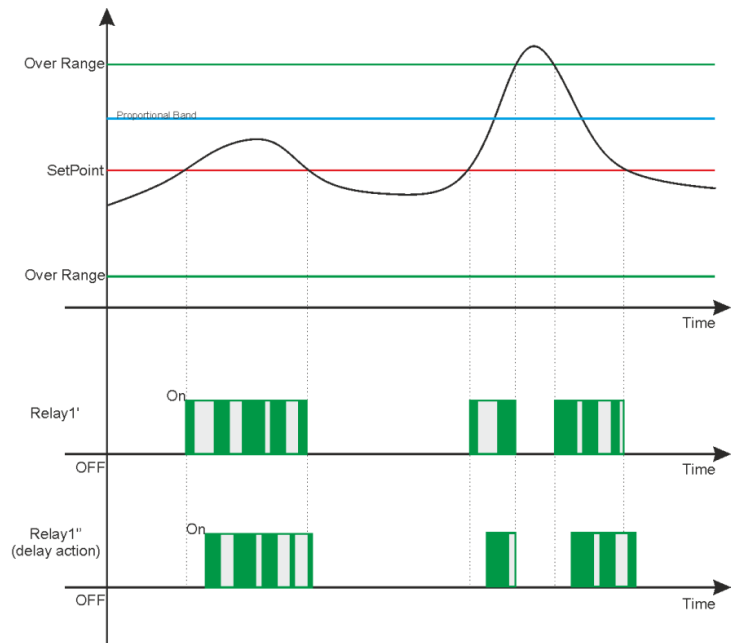

### Note:



- Relay Activation:** When the measure (black line) exceeds the SetPoint the relay is activated and the proportional times On and Off are executed as calculated in relation to the proportional band set in the menu items "10" and "11"; this status is maintained until the measure decreases at the SetPoint value (see relay 1').
- Delay Activation:** By setting the menu items "5" and "6" the relay activation will be delayed equal to the set time (see relay 1'')
- Chemical Measure out of range:** When the measure (black line) exceeds the maximum or minimum Over Range value (green line), the system displays a visual alarm and blocks the dosage by changing the status of the relay 1 or 2.

**Low Function:** By setting the menu item "2" with the variable Low the relays activations are inverted compared to the above diagram.

**Hysteresis Function:** By setting the menu items "3" and "4" the instrument maintains the relay activation status both for the chemical measure value and for the time.

DosingPump.ir

## ANNEX C: PROPORTIONAL (PWM) RELAY SETUP WITH OFA FUNCTION.

Below is an example of settings for the Relay 1 or 2 to adjust the Conductivity using the proportional (PWM) method with OFA timers.

2A RELAY_1_PWM	
1: SetPoint	720 $\mu$ S
2: Type	High
3: Hysteresis	0.00 $\mu$ S
4: Hyst. Time	00' 00"
5: Delay Start	00' 00"
6: Delay End	00' 00"
7: OFA	OFF
8: Over Range	200 $\mu$ S
9: Interval	02' 00"
10: Prop. Band	100 $\mu$ S

01/10

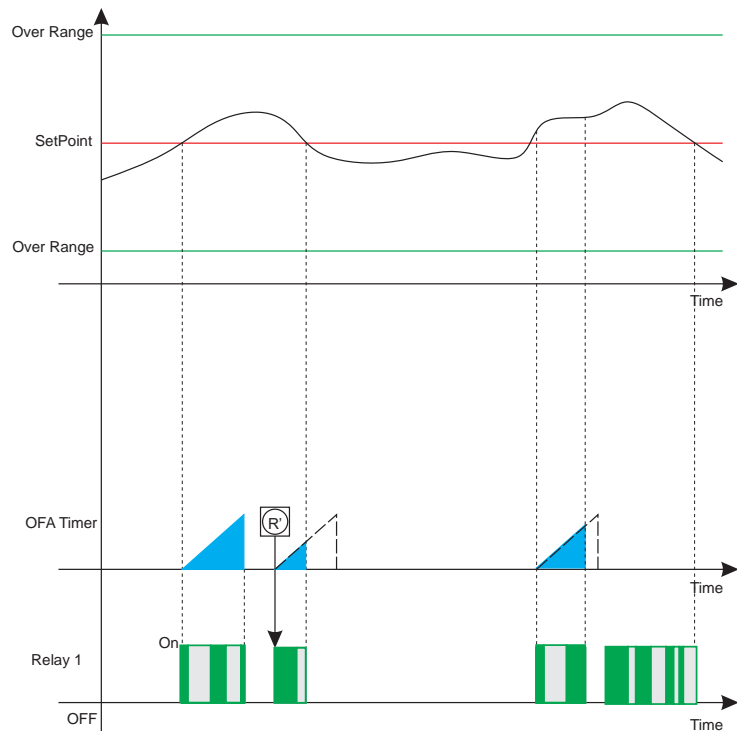

All the settings described on the previous page remain valid.

### Note:



- OFA (Over Feed Alarm):** By setting the function "7" OFA with a time in hours and minutes a control timer is activated in parallel to the relay activation. The function checks the activated relay persistence times and generates a visual prealarm at 70% of set value and a blocking alarm (R') at the end of the set time (100%). A manual intervention will be required to remove the blocking with the reset of the OFA function on the alarms menu (see alarms section).

## ANNEX D: RELAY 2 SETUP FOR AUTOMATIC WASHING

Below is an example of settings for Relay 2 with Washing function to automate the probe cleaning with an external device(\*).

2B Relay 2	
▶ 1: Wash	05' 00"
2: Delay	05' 00"
3: Wait	06h 00m
01/03	

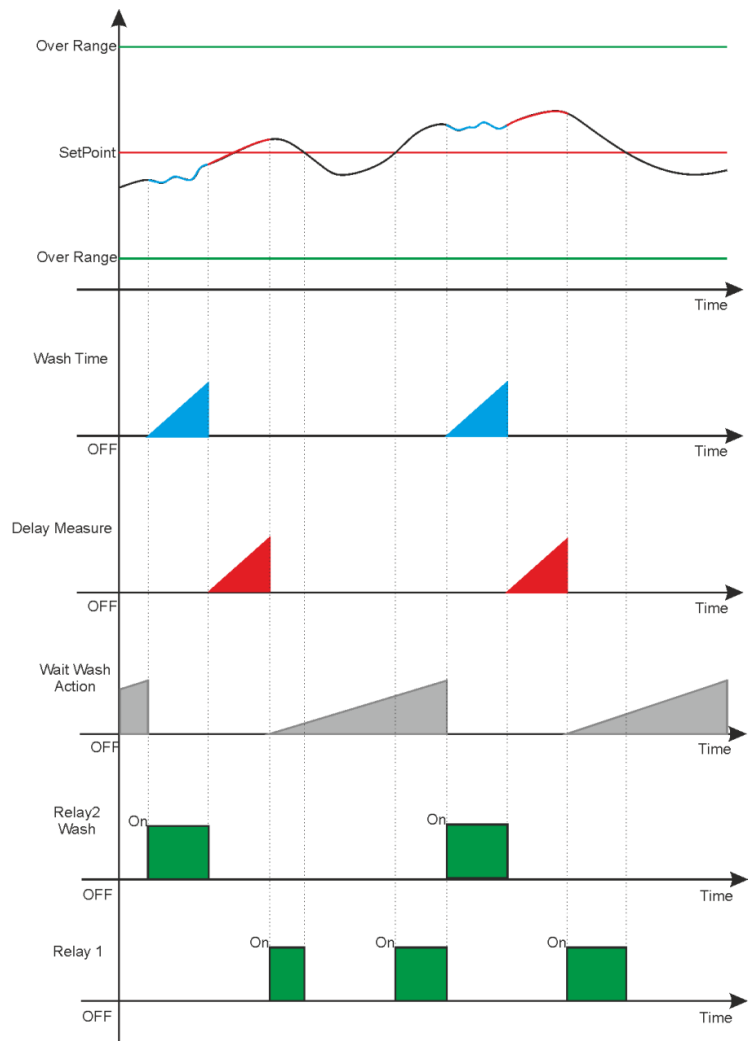

### Note:



- **Wash Time:** Relay 2 is activated at the end of "Wait New Wash" timer and starts operating an external device to the set time. The instrument displays a service message by deleting the displayed measure and blocking all the instrument's functions (Amber color Backlight).
- **Delay Measure:** Relay 2 is turned off for the set time by displaying the measure and maintaining all the instrument's functions blocked (Amber color Backlight).
- **Wait New Wash:** The instrument counts the set time by performing the normal functions of measure and control; when the time expires, the "Wash Time" is activated.

(\* The external washing system is not supplied with the instrument)

DosingPump.ir

## ANNEX E: RELAY 2 SETUP TO REPEAT REMOTE ALARM.

(\*To set the Relay 2 for Remote Alarm see Advanced Setup Menu 3H)

On Setup Menu 2B it is possible to set the alarm conditions to be repeated by Relay 2; attention, check the Advanced Menu "3G" Alarms Configuration.

2B Relay 2	
▶ 1: R1 OverRng	NO
2: R1 OFA	NO
3: Reed Alarm	NO
6: Temp. Alarm	NO
01/04	

3G Alarms Conf.	
▶ 1: Reed Logic	NO
2: Reed Delay	00'00"
3: Block	No
4: Alarm Temp.	Notify
01/04	

Table with the alarm messages displayed by the instrument.

Number	Alarm	Message	Status
1	Not Present	No Item	
2	External Reed Input Active	Reed	Alarm with instrument blocking (*)
3	Temperature Sensor Broken or Disconnected	Alarm Fault Temp.	Alarm with instrument blocking (**)
4	Relay 1 Timer decreased at 70%	OFA1 R1	Preliminary Alarm
5	Relay 1 Timer decreased at 100%	OFA2 R1	Alarm with instrument blocking (*)
6	Chemical Measure outside of working range	Over Range R1	Alarm with instrument blocking (*)
7	Relay 2 Timer decreased at 70%	OFA1 R2	Preliminary Alarm
8	Relay 2 Timer decreased at 100%	OFA2 R2	Alarm with instrument blocking (*)
9	Chemical Measure outside of working range	OverRange R2	Alarm with instrument blocking (*)
10	Probe in the Air	Probe in the Air	Alarm with instrument blocking
11	Probe in Short Circuit	Probe in Short C	Alarm with instrument blocking

(\*All the alarms with blocking function are valid if the menu item 3G5 is equal to YES)

(\*\*The temperature sensor breakage alarm blocks the instrument if the menu item 3G6 is equal to YES)



### Note:

- **Reset Alarms Log:** On view Measure (Meas Icon) there is available an Alarm status menu; by pressing the **Enter** key, the **Alarms Menu** will be displayed.



**Nota:** Note: Alarms are stored in memory every 15 minutes, watch if the instrument is switched off loses alarms displayed in the last 14 minutes.

## ANNEX F: SSR1 SETUP

Proportional frequency output with independent Proportional Band and SetPoint.

2C SSR1	
1: SetPoint	740 $\mu$ S
2: Type	High
3: Pulse Max	400
4: Pulse min	1
5: Prop. Band	200 $\mu$ S

01/05

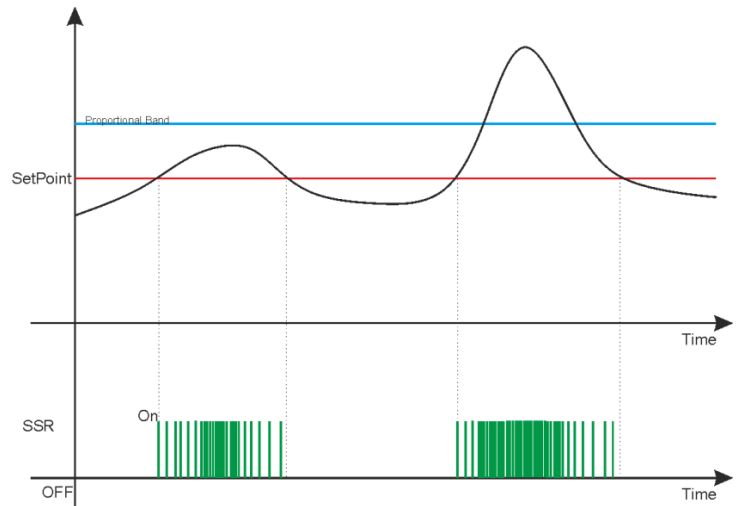

### Note:



- **Pulse Max:** Set the maximum value of pulses for chemical measure higher than the proportional band value.
- **Pulse min:** Set the minimum value of pulses for measure near the SetPoint value.
- **Pulse Technical Data:** Pulse On duration is fixed at 100mSeconds and time Off duration varies from 50mS (400 pulses per minute) to 59900mS (1 pulse per minute).



**Notes:** The Alarm Over Range function is not present on frequency output.

DosingPump.ir



## ANNEX G: MA1 SETUP

Current output proportional to the measure with range from 4 mA to 20 mA.

<b>20 mA1</b>	
▶ 1: Start mA	0 $\mu$ S
2: End mA	20000 $\mu$ S
3: Hold	NO
4: Namur	OFF
01/04	

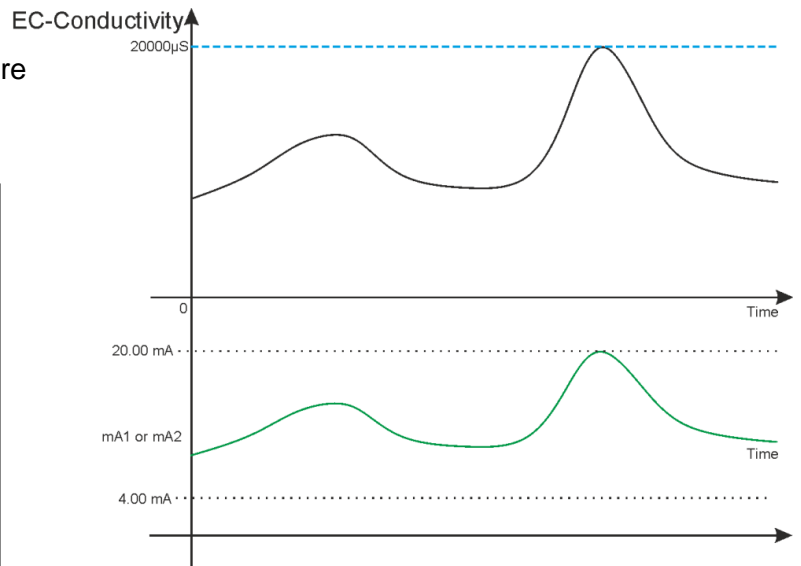

### Note:



- **Start mA:** Minimum value of chemical measure associated to 4 mA
- **End mA:** Maximum value of chemical measure associated to 20 mA
- **Hold:** By setting the variable to YES, in case of alarm the instrument freezes the mA output to the last calculated value.
- **Namur:** By setting the variable to the value of 3.6 mA or 22 mA, in case of alarm the instrument sets the current output to the selected value.

DosingPump.ir

## ANNEX H: WIRING EXAMPLES



### Power Supply:

- 230Vac, 115Vac or 24Vac 50/60Hz; check the product label
- Observe the polarity
- Maximum Power Consumption 3,6VA

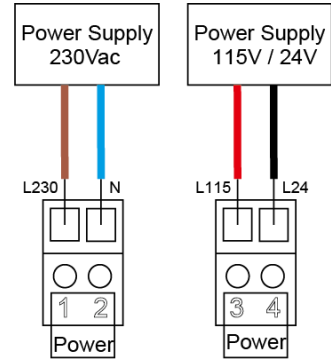

### Frequency output SSR1:

- Contact closed approx. 3Ω, 100mA maximum load.

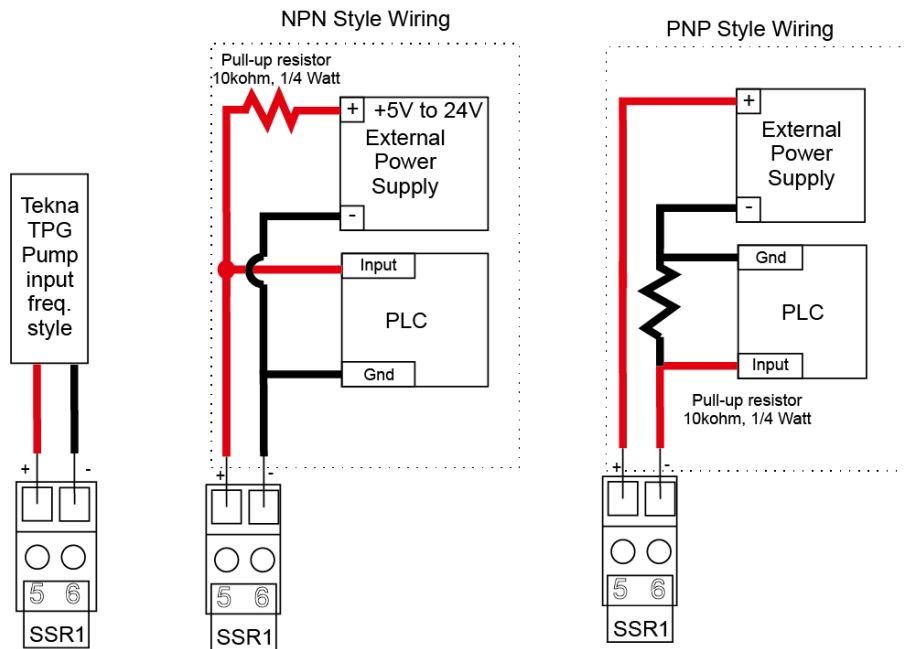

### Relay outputs 1 and 2:

- Maximum load 5 A resistive

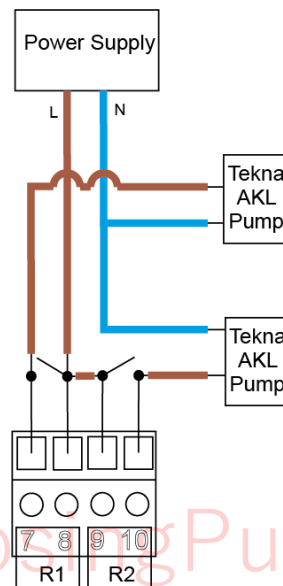

**Current output mA 1:**

- 4-20mA with a maximum load of 500 ohm
- Observe the polarity of the cables

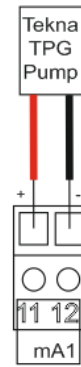

**Reed sensor input:**

- Input for dry contact or semiconductor (Open Collector) 5Vcc, max 6mA.
- Maximum distance of the Reed sensor 20 meters of cable.

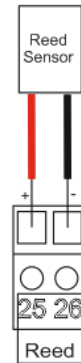

**Conductivity measure input:**

- Attention, connect the probes with metal terminals
- Observe the polarity
- Maximum distance of the Conductivity sensor 50 meters of cable.

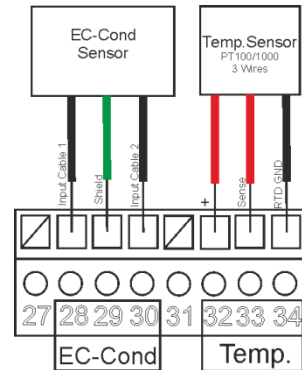

**Temperature measure input:**

- Attention, connect the probes with metal terminals
- Observe the polarity
- Maximum distance of the PT100/PT1000 sensor 20 meters of cable
- Observe the wiring for the sensor, with 2, 3 and 4 wires; connect as indicated.

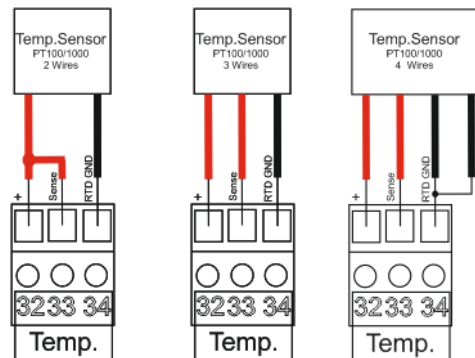

## ANNEX I: TROUBLESHOOTING.

Problem	Possible Cause
The display shows the symbol 	<ul style="list-style-type: none"> <li>• See ANNEX E</li> </ul>
Calibration Errors	<ul style="list-style-type: none"> <li>• Contaminated buffer solutions (old)</li> <li>• Probe damaged or old</li> <li>• Probe cables damaged</li> <li>• Measure input of the instrument damaged</li> </ul>
Data Memory Error	<ul style="list-style-type: none"> <li>• Internal memory broken</li> </ul>
Password Error	<ul style="list-style-type: none"> <li>• Error value</li> </ul>
Temperature Measure Error the display shows <span style="border: 1px solid black; padding: 2px;">---.°C</span>	<ul style="list-style-type: none"> <li>• Temperature probe broken or disconnected</li> </ul>
Chemical Measure Error	<ul style="list-style-type: none"> <li>• Sensor not calibrated</li> <li>• Sensor not installed correctly</li> <li>• Temperature compensation incorrectly set or disabled</li> <li>• The sensor or the cable is defective</li> <li>• Electronic measure input damaged</li> <li>• The sensor cable exceeds the maximum length</li> </ul>
Measure reading not stable	<ul style="list-style-type: none"> <li>• Sensors or cables installed too close to devices that generate electrical noise.</li> <li>• Sensor installed on flow with hydraulic turbulence.</li> <li>• Average measure set too low.</li> <li>• Probe cables excessively long</li> </ul>
Unable to display the Calibration or Setup menu	<ul style="list-style-type: none"> <li>• User excluded for safety reasons</li> </ul>
The display is turned off	<ul style="list-style-type: none"> <li>• The instrument does not receive correct power supply.</li> <li>• LCD contrast is not set correctly.</li> <li>• The fuse has blown.</li> <li>• Hardware fault.</li> </ul>
The display shows in the upper right corner "Diagnostic"	<ul style="list-style-type: none"> <li>• Turn the instrument off and then on again; if the problem persists, contact your provider</li> </ul>
Probe in Air Alarm	<ul style="list-style-type: none"> <li>• Wiring damaged</li> <li>• Liquid is missing</li> </ul>
Probe in Short Circuit Alarm	<ul style="list-style-type: none"> <li>• Wiring damaged</li> <li>• Foreign object in contact with the electrodes</li> </ul>

## ANNEX L: DEFAULT PARAMETERS TABLE AND RESET TO DEFAULT

ADVANCED MENU					
Parameter	Sub-parameter	Default Value	Min Value	Max Value	Unit
Language	---	EN (English)	EN,FR,IT,DE,ES,CN		
Password	Password	0000	0000	9999	
	Cal Menu	NO	NO	YES	
	Setup Menu	NO	NO	YES	
Display	Contrast	0	-15	+15	
	Mode	ECO	OFF, ON, ECO		
	ON	100	10	100	%
	ECO	50	0	50	%
	Inversion	OFF	OFF	ON	
Chemical Meas.	Measure Unit	µS	µS,mS,KΩ,MΩ,ppm,ppb		
	Temp. Compensation	OTC	OTC,MTC,ATC		
	Filter	Medium	Low, Medium, High		
	TDS	0,7	0,3	2,0	ppm/µS
	Decimal Point	XXX,XX	XXXXX, / XXXX,X / XXX,XX / XX,XXX / X,XXXX		
Temperature Meas.	Sensor Type	Manual	Manual	External	
	Measure Unit	°C	°C	°F	
	Manual Value	25,0 (77,0)	0,0 (32,0)	+100,0 (212,0)	°C (°F)
	Filter	Medium	Low, Medium, High		
	Compensation Type	Lin25°C	Pure H2O,Lin25°C,Lin20°C		
	Linear Coefficient	2,00	0,01	10,00	%/°C
Cell Constant	Type	Standard	Standard	Custom	
	Standard	1,00	0,01 / 0,10 / 0,20 / 1,00 / 10,0		
	Custom	---	0,005	20,000	cm <sup>-1</sup>
	Actual	1,00	Not Changeable		cm <sup>-1</sup>
Alarms Config.	Reed Logic	NO	NO	NC	
	Delay Activation REED	OFF	OFF (00':00")	60':59"	min:sec
	Instrument blocking	NO	NO	YES	
	Temperature Alarm	Notification	Notification	Block	
Outputs Config.	Relay 1	OFF	OFF, Meas ON/OFF, Meas Timed, Meas. PWM, OFF, Meas ON/OFF, Meas Timed, Meas. PWM, Temp. ON/OFF, Temp. Timed, Temp. PWM, Probe Wash, Alarm		
	Relay 2	OFF	OFF, Measure, Temp.		
	SSR1	OFF	OFF, Measure, Temp.		
	mA1	OFF	OFF, Measure, Temp.		
Control Panel	Chemical Measure	---	0	2000	KΩ
	Temperature Measure	---	0,0	+100,0	°C
	Simul. Relay 1	OFF	OFF	ON	
	Simul. Relay 2	OFF	OFF	ON	
	Simul. Freq 1	0	0	400	Imp/min
	Simul. Out mA 1	4,00	3,00	23,00	mA
	REED Input	---	OFF	ON	
	Reset Statistics	NO	NO	YES	
System Reset	---	NO	NO	YES	
Firmware Revision	---	---	---	---	

SETUP MENU					
<b>Relay 1 = OFF, Relay 2 = OFF, SSR1 = OFF, mA1 = OFF</b>					
Parameter	Sub-parameter	Default Value	Min Value	Max Value	Unit
Relay 1	---	OFF	---	---	
Relay 2	---	OFF	---	---	
SSR1	---	OFF	---	---	
mA1	---	OFF	---	---	

DosingPump.ir

SETUP MENU		Chemical Measure Unit: $\mu\text{S}, \text{mS}, \text{K}\Omega, \text{M}\Omega, \text{ppm}, \text{ppb}$				
Parameter	Sub-parameter 1	Sub-parameter 2	Default Value	Min Value	Max Value	Unit
Relay 1 / Relay 2 EC ON/OFF	SetPoint	---	0	0,0000	99999	*note1
	Type	---	Low	Low	High	
	Hysteresis	---	0	0,0000	99999	*note1
	Hysteresis Time	---	OFF	OFF (00':00")	2':59"	min:sec
	Delay Start	---	00':01"	OFF (00':00")	60':59"	min:sec
	Delay End	---	00':01"	OFF (00':00")	60':59"	min:sec
	OFA	---	OFF	OFF (00h:00')	23h:59'	hours:min
	Over Range	---	0	0,0000	99999	*note1
Relay 1 / Relay 2 EC TIMED	Time On	---	00':10"	OFF (00':00")	60':59"	min:sec
	Time Off	---	00':10"	OFF (00':00")	60':59"	min:sec
Relay 1 / Relay 2 EC PWM	Interval	---	02':00"	OFF (00':00")	60':59"	min:sec
	Proportional Band	---	0	0,0000	99999	*note1

\*note1:  $\mu\text{S}, \text{mS}, \text{K}\Omega, \text{M}\Omega, \text{ppm}, \text{ppb}$

SETUP MENU		Temperature Measure Unit: $^{\circ}\text{C}$				
Parameter	Sub-parameter 1	Sub-parameter 2	Default Value	Min Value	Max Value	Unit
Relay 2 $^{\circ}\text{C}$ ON/OFF	SetPoint	---	25,0	0,0	100,0	$^{\circ}\text{C}$
	Type	---	Low	Low	High	
	Hysteresis	---	0,0	0,0	10,0	$^{\circ}\text{C}$
	Hysteresis Time	---	OFF	OFF (00':00")	2':59"	min:sec
	Delay Start	---	00':01"	OFF (00':00")	60':59"	min:sec
	Delay End	---	00':01"	OFF (00':00")	60':59"	min:sec
	OFA	---	OFF	OFF (00h:00')	23h:59'	hours:min
	Over Range	---	OFF	OFF (0,0)	100,0	$^{\circ}\text{C}$
Relay 2 $^{\circ}\text{C}$ TIMED	Time On	---	00':10"	OFF (00':00")	60':59"	min:sec
	Time Off	---	00':10"	OFF (00':00")	60':59"	min:sec
Relay 2 $^{\circ}\text{C}$ PWM	Interval	---	02':00"	OFF (00':00")	60':59"	min:sec
	Proportional Band	---	10,0	1,0	50,0	$^{\circ}\text{C}$

SETUP MENU		Temperature Measure Unit: $^{\circ}\text{F}$				
Parameter	Sub-parameter 1	Sub-parameter 2	Default Value	Min Value	Max Value	Unit
Relay 2 $^{\circ}\text{F}$ ON/OFF	SetPoint	---	77,0	32,0	212,0	$^{\circ}\text{F}$
	Type	---	Low	Low	High	
	Hysteresis	---	0,0	0,0	18,0	$^{\circ}\text{F}$
	Hysteresis Time	---	OFF	OFF (00':00")	2':59"	min:sec
	Delay Start	---	00':01"	OFF (00':00")	60':59"	min:sec
	Delay End	---	00':01"	OFF (00':00")	60':59"	min:sec
	OFA	---	OFF	OFF (00h:00')	23h:59'	hours:min
	Over Range	---	OFF	OFF (0,0)	180,0	$^{\circ}\text{F}$
Relay 2 $^{\circ}\text{F}$ TIMED	Time On	---	00':10"	OFF (00':00")	60':59"	min:sec
	Time Off	---	00':10"	OFF (00':00")	60':59"	min:sec
Relay 2 $^{\circ}\text{F}$ PWM	Interval	---	02':00"	OFF (00':00")	60':59"	min:sec
	Proportional Band	---	18,0	1,8	90,0	$^{\circ}\text{F}$

SETUP MENU		Relay 2 = Probe Wash				
Parameter	Sub-parameter 1	Sub-parameter 2	Default Value	Min Value	Max Value	Unit
Relay 2 pH/mV Wash	Wash Time	---	OFF	OFF (00':00")	60':59"	min:sec
	Delay Stabilization	---	01':00"	OFF (00':00")	60':59"	min:sec
	Wait New Wash	---	24h:00'	OFF (00h:00')	99h:59'	hours:min

DosingPump.ir

SETUP MENU		Relay 2 = Alarm				
Parameter	Sub-parameter 1	Sub-parameter 2	Default Value	Min Value	Max Value	Unit
Relay 2 Alrm	Over Range R1	---	NO	NO	YES	
	OFA R1	---	NO	NO	YES	
	Alarm REED	---	NO	NO	YES	
	Alarm Temperature Probe	---	NO	NO	YES	

SETUP MENU		Chemical Measure Unit: $\mu$ S,mS,K $\Omega$ ,M $\Omega$ ,ppm,ppb				
Parameter	Sub-parameter 1	Default Value	Min Value	Max Value	Unit	
SSR1 EC	SetPoint	0	0,0000	99999	*note 1	
	Type	Low	Low	High		
	Max Pulses	400	20	400	Imp/min	
	Min Pulses	1	1	100	Imp/min	
	Proportional Band	0	0,0000	99999	*note 1	

\*note 1:  $\mu$ S,mS,K $\Omega$ ,M $\Omega$ ,ppm,ppb

SETUP MENU		Temperature Measure Unit: $^{\circ}$ C				
Parameter	Sub-parameter 1	Default Value	Min Value	Max Value	Unit	
SSR1 $^{\circ}$ C	SetPoint	25,0	0,0	100,0	$^{\circ}$ C	
	Type	Low	Low	High		
	Max Pulses	400	20	400	Imp/min	
	Min Pulses	1	1	100	Imp/min	
	Proportional Band	10,0	1,0	50,0	$^{\circ}$ C	

SETUP MENU		Temperature Measure Unit: $^{\circ}$ F				
Parameter	Sub-parameter 1	Default Value	Min Value	Max Value	Unit	
SSR1 $^{\circ}$ F	SetPoint	77,0	32,0	212,0	$^{\circ}$ F	
	Type	Low	Low	High		
	Max Pulses	400	20	400	Imp/min	
	Min Pulses	1	1	100	Imp/min	
	Proportional Band	18,0	1,8	90,0	$^{\circ}$ F	

SETUP MENU		Chemical Measure Unit: $\mu$ S,mS,K $\Omega$ ,M $\Omega$ ,ppm,ppb				
Parameter	Sub-parameter 1	Default Value	Min Value	Max Value	Unit	
mA1 EC	Start mA	0	0,0000	99999	*note 1	
	End mA	99999	0,0000	99999	*note 1	
	Hold Measure	NO	NO	YES		
	Namur	OFF, 3,6mA, 22 mA				

\*note 1:  $\mu$ S,mS,K $\Omega$ ,M $\Omega$ ,ppm,ppb

SETUP MENU		Temperature Measure Unit: $^{\circ}$ C				
Parameter	Sub-parameter 1	Default Value	Min Value	Max Value	Unit	
mA1 $^{\circ}$ C	Start mA	0,0	0,0	100,0	$^{\circ}$ C	
	End mA	100,0	0,0	100,0	$^{\circ}$ C	
	Hold Measure	NO	NO	YES		
	Namur	OFF, 3,6mA, 22 mA				

SETUP MENU		Temperature Measure Unit: $^{\circ}$ F				
Parameter	Sub-parameter 1	Default Value	Min Value	Max Value	Unit	
mA1 $^{\circ}$ F	Start mA	32,0	32,0	212,0	$^{\circ}$ F	
	End mA	212,0	32,0	212,0	$^{\circ}$ F	
	Hold Measure	NO	NO	YES		
	Namur	OFF, 3,6mA, 22 mA				

## RESET THE DEFAULT PARAMETERS OF THE INSTRUMENT

To load all the default parameters of the instrument and also remove the password, proceed as follows:

- A) Disconnect the instrument from the power supply
- B) Press and hold simultaneously **Down** and **Enter** and power the instrument.
- C) At startup the instrument will execute a hidden menu
- D) Will be displayed the following message (picture on the A) Side)
- B) Select "YES" to perform the **RESET TO DEFAULT**.
- C) The instrument turns on and performs the **STARTUP** function.

