

# Hydraulic diaphragm process metering pumps

**API 675**

**XL**

**XL-B**

**XL-C**

*The ultimate diaphragm process metering pump!*



[DosingPump.ir](http://DosingPump.ir)



# API 675

Hydraulic diaphragm process metering pumps

## XL - XLB - XLC

XL pumps series (hydraulic diaphragm positive return) since they were launched on the market achieved a great deal of success thanks to the incredible price/quality ratio. They were further developed and improved with the XLB and XLC pumps. These pumps, with cast iron casing, designed and manufactured in full conformity with API 675 STD and ATEX 94/9/CE, zone of danger 1/21 e 2/22, are suitable for 24/7 demanding industrial applications.

XLB double hydraulic diaphragm metering pump with PVDF wetted parts. Diaphragm rupture detector via ATEX II 2 G Ex-d IIC T6. pressure switch. Because of the pH of the dosed chemical pressure switch had to be protected by a PTFE diaphragm fitted into two in Hastelloy C 276<sup>®</sup> backing rings. Because of the weight of the pressure switch and its protection system they are both supported by a bar made of AISI 316 bar. Same material is used for the base-plate to comply with stringent project specifications. >



As all OBL hydraulic diaphragm, these pumps come with built-in relief valve, air purge valve and mechanically actuated replenishing (smart diaphragm).

This valve guarantees at all times a constant hydraulic balance that **overcomes all suction problems** (suction valve closing, decreasing of NPSH available).

In case of worsening of the NPSH available, though volumetric efficiency would decrease, **pump would still deliver chemical.**

In case of complete closing of suction isolating valve, pump would not over-replenish oil and diaphragm

would not be over-stretched.

**Once operating condition are restored, pump automatically starts delivering with no damage whatsoever.**

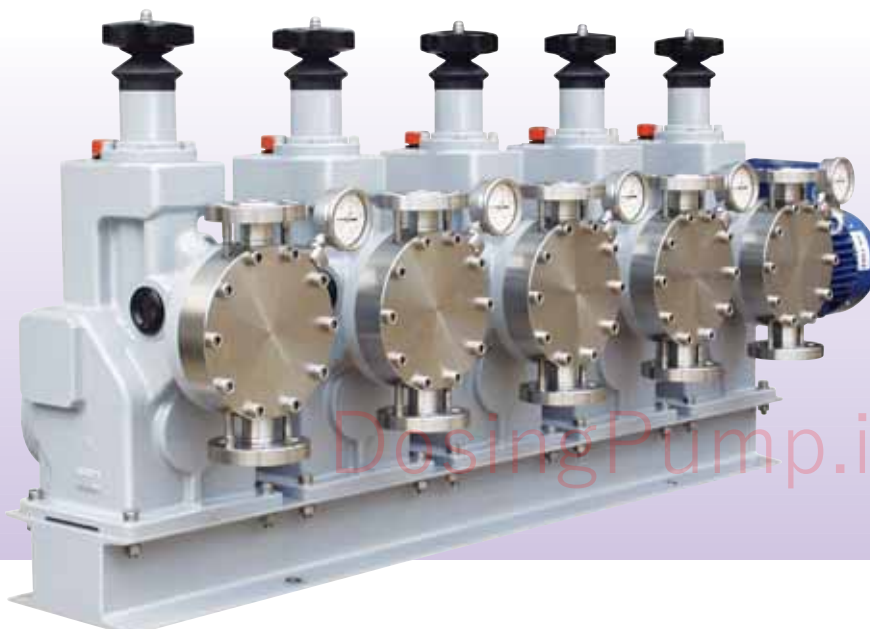

< Five headed XLB metering pump with independent manual adjustments. AISI 316L wetted parts pump head with double diaphragm and visual rupture detector. Pump conforms to ATEX 94/9/CE, suitable, thanks to the double hydraulic diaphragm system, for dosing of flammable, toxic and explosive chemicals.

## Constructional data

- Hydraulic diaphragm pump (single or double), with rupture detector both visual as well as remote (via pressure switch or pressure transmitter for both safe and hazardous areas).

- Design fully conforming with API 675 STD.

- Performances conforming to API 675 STD:

±1% steady state accuracy between 10 and 100% of rated capacity;  
 ± 3% linearity between 10 and 100% of rated capacity;  
 ± 3% repeatability between 10 and 100% of rated capacity.

- Thanks to unique design, pump head can be dismantled and diaphragm checked, with no oil loss.

- Zero flow rate when pressure is zero and adjustment being set to "0%".

- Reduced maintenance; seamless oil-bathed plunger that guarantees as-new volumetric efficiency even after 50000 working hours. Diaphragm, protected by built-in relief valve and mechanical replenisher has working life in excess of 50000 working hours.

- Multiple pumps arrangement on demand (each pump can have different pump size, strokes/1' and wetted materials). These series can be ganged with other positive return pumps (L or X9 series); adjustment can be either independent or common.

- Standard automatic adjustment is via 0,1% steps knob.

- Pumps can be supplied with either electrical or pneumatic actuators (for both safe and hazardous areas) as well as with VSD rated motors.

- Wetted materials are: AISI 316L, PP, PVC and PVDF. On demand exotic materials (alloy 20, Hastelloy C 276, Titanium) can be supplied.

- IEC as standard but NEMA motors can be supplied too.

## Applications field:

- OIL&GAS
- CHEMICAL AND PETRO-CHEMICAL
- POWER GENERATION
- WATER TREATMENT
- PULP & PAPER
- DEMINERALISATION AND RO PLANTS

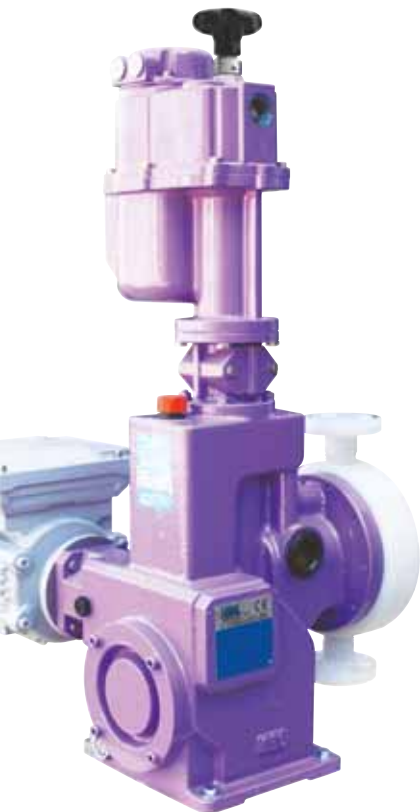

XL pump with single diaphragm and PVDF wetted parts. Automatic adjustment of the flow rate via OBL-designed electrical actuator that being IP66 and thanks to the anticondensation heater, turns out to be suitable for installation in harsh environments such as saline and/or deserts areas with high humidity and wide temperature variation.



< XLC AISI 316L basic version with: double diaphragm with local visual rupture detector and flanged connections.

# XL

|                       |  |
|-----------------------|--|
| <b>Pump:</b>          | • Single and multiple  |
| <b>Max flow rate:</b> | • 480 L/h  |
| <b>Max pressure:</b>  | • 15 bar   |
| <b>Motors:</b>        | • Threephase 0,37 kW - 0,75 kW - 1,5 kW<br>230/400 V - 50/60Hz - 4 poles<br>IP55 - CLF - IEC38 |
| <b>Stroke:</b>        | • 15/25mm  |
| <b>Materials:</b>     | • Cast iron pump body  |
| <b>Weigh:</b>         | • 60÷70 Kgs  |



480 l/h 15 bar

## API 675

XL pump technically advanced hydraulic diaphragm positive return pump, low cost, due to reduced number of components; can be used in both process and service applications.

- Hydraulic diaphragm metering pump both single and double
- Threaded (BSP female) or flanged connections (both DIN or ANSI)
- Fully conforming with API 675 STD
- Fully conforming with ATEX 94/9/CE, 1/21 and 2/22 zone of danger. Suitable for flammable chemicals thanks to the double diaphragm system
- PP wetted parts (single diaphragm only), AISI 316L, PVC e PVDF (with single and double diaphragm design)
- With PP, AISI 316L and PVDF wetted parts up to 60 °C pumping temperature
- With PVC wetted parts up to 40 °C pumping temperature



DosingPump.ir

< Two-headed XL.

Each pump can have different number of strokes/1' and different wetted materials.

## Technical characteristics

< XL single hydraulic diaphragm pump head with injection moulded glass filled PP and threaded connections. Max pressure up to 15 bar g.

| TYPE                 | STROKES/1' | MAX FLOW RATE I/H | PVS SET PRESS. bar g |     |      | CONNECTIONS |                    |      |
|----------------------|------------|-------------------|----------------------|-----|------|-------------|--------------------|------|
|                      |            |                   | WORK PRES.           | PVS | kW   | THREADED    | FLANGED            |      |
|                      |            |                   |                      |     |      |             | UNI                | ANSI |
| <b>50 Hz</b>         |            |                   |                      |     |      |             |                    |      |
| <b>PP-PP11-PP32</b>  |            |                   |                      |     |      |             |                    |      |
| XL 15.50             | 40         | 63                | 12                   | 15  | 0,37 | 1/2" BSPF   | DN15-PN16 1/2" 150 |      |
| XL 25.50             | 40         | 105               | 12                   | 15  | 0,37 | 1/2" BSPF   | DN15-PN16 1/2" 150 |      |
| XL 25.50             | 60         | 155               | 12                   | 15  | 0,37 | 1/2" BSPF   | DN20-PN16 3/4" 150 |      |
| XL 25.50             | 82         | 215               | 12                   | 15  | 0,75 | 1/2" BSPF   | DN20-PN16 3/4" 150 |      |
| XL 25.50             | 100        | 260               | 12                   | 15  | 0,75 | 3/4" BSPF   | DN20-PN16 3/4" 150 |      |
| XL 25.50             | 123        | 320               | 12                   | 15  | 0,75 | 3/4" BSPF   | DN20-PN16 3/4" 150 |      |
| XL 25.50             | 140        | 370               | 11                   | 14  | 0,75 | 1" BSPF     | DN25-PN16 1" 150   |      |
| XL 25.50             | 160        | 430               | 10                   | 13  | 0,75 | 1" BSPF     | DN25-PN16 1" 150   |      |
| XL 25.50             | 185        | 480               | 8                    | 10  | 0,75 | 1" BSPF     | DN25-PN16 1" 150   |      |
| <b>MA-MMA</b>        |            |                   |                      |     |      |             |                    |      |
| XL 15.50             | 40         | 63                | 12                   | 15  | 0,37 | 1/2" BSPF   | DN15-PN16 1/2" 150 |      |
| XL 25.50             | 40         | 105               | 12                   | 15  | 0,37 | 1/2" BSPF   | DN15-PN16 1/2" 150 |      |
| XL 25.50             | 60         | 155               | 12                   | 15  | 0,37 | 1/2" BSPF   | DN20-PN16 3/4" 150 |      |
| XL 25.50             | 82         | 215               | 12                   | 15  | 0,75 | 1/2" BSPF   | DN20-PN16 3/4" 150 |      |
| XL 25.50             | 100        | 260               | 12                   | 15  | 0,75 | 3/4" BSPF   | DN20-PN16 3/4" 150 |      |
| XL 25.50             | 123        | 320               | 12                   | 15  | 0,75 | 3/4" BSPF   | DN20-PN16 3/4" 150 |      |
| XL 25.50             | 140        | 370               | 11                   | 14  | 0,75 | 1" BSPF     | DN25-PN16 1" 150   |      |
| XL 25.50             | 160        | 430               | 10                   | 13  | 0,75 | 1" BSPF     | DN25-PN16 1" 150   |      |
| XL 25.50             | 185        | 480               | 8                    | 10  | 0,75 | 1" BSPF     | DN25-PN16 1" 150   |      |
| <b>MP-MMP/MS-MMS</b> |            |                   |                      |     |      |             |                    |      |
| XL 15.50             | 40         | 63                | 12                   | 15  | 0,37 | -           | DN15-PN16 1/2" 150 |      |
| XL 25.50             | 40         | 105               | 12                   | 15  | 0,37 | -           | DN15-PN16 1/2" 150 |      |
| XL 25.50             | 60         | 155               | 12                   | 15  | 0,37 | -           | DN20-PN16 3/4" 150 |      |
| XL 25.50             | 82         | 215               | 12                   | 15  | 0,75 | -           | DN20-PN16 3/4" 150 |      |
| XL 25.50             | 100        | 260               | 12                   | 15  | 0,75 | -           | DN25-PN16 1" 150   |      |
| XL 25.50             | 123        | 320               | 12                   | 15  | 0,75 | -           | DN25-PN16 1" 150   |      |
| XL 25.50             | 140        | 370               | 11                   | 14  | 0,75 | -           | DN25-PN16 1" 150   |      |
| XL 25.50             | 160        | 430               | 10                   | 13  | 0,75 | -           | DN25-PN16 1" 150   |      |
| XL 25.50             | 185        | 480               | 8                    | 10  | 0,75 | -           | DN25-PN16 1" 150   |      |
| <b>60 Hz</b>         |            |                   |                      |     |      |             |                    |      |
| <b>PP-PP11-PP32</b>  |            |                   |                      |     |      |             |                    |      |
| XL 15.50             | 48         | 76                | 12                   | 15  | 0,37 | 1/2" BSPF   | DN15-PN16 1/2" 150 |      |
| XL 25.50             | 48         | 126               | 12                   | 15  | 0,37 | 1/2" BSPF   | DN15-PN16 1/2" 150 |      |
| XL 25.50             | 72         | 186               | 12                   | 15  | 0,75 | 1/2" BSPF   | DN20-PN16 3/4" 150 |      |
| XL 25.50             | 96         | 258               | 12                   | 15  | 0,75 | 3/4" BSPF   | DN20-PN16 3/4" 150 |      |
| XL 25.50             | 121        | 312               | 12                   | 15  | 0,75 | 3/4" BSPF   | DN20-PN16 3/4" 150 |      |
| XL 25.50             | 144        | 384               | 11                   | 14  | 0,75 | 1" BSPF     | DN25-PN16 1" 150   |      |
| XL 25.50             | 168        | 444               | 10                   | 13  | 0,75 | 1" BSPF     | DN25-PN16 1" 150   |      |
| <b>MA-MMA</b>        |            |                   |                      |     |      |             |                    |      |
| XL 15.50             | 48         | 76                | 12                   | 15  | 0,37 | 1/2" BSPF   | DN15-PN16 1/2" 150 |      |
| XL 25.50             | 48         | 126               | 12                   | 15  | 0,37 | 1/2" BSPF   | DN15-PN16 1/2" 150 |      |
| XL 25.50             | 72         | 186               | 12                   | 15  | 0,75 | 1/2" BSPF   | DN20-PN16 3/4" 150 |      |
| XL 25.50             | 96         | 258               | 12                   | 15  | 0,75 | 3/4" BSPF   | DN20-PN16 3/4" 150 |      |
| XL 25.50             | 121        | 312               | 12                   | 15  | 0,75 | 3/4" BSPF   | DN20-PN16 3/4" 150 |      |
| XL 25.50             | 144        | 384               | 11                   | 14  | 0,75 | 1" BSPF     | DN25-PN16 1" 150   |      |
| XL 25.50             | 168        | 444               | 10                   | 13  | 0,75 | 1" BSPF     | DN25-PN16 1" 150   |      |
| <b>MP-MMP/MS-MMS</b> |            |                   |                      |     |      |             |                    |      |
| XL 15.50             | 48         | 76                | 12                   | 15  | 0,37 | -           | DN15-PN16 1/2" 150 |      |
| XL 25.50             | 48         | 126               | 12                   | 15  | 0,37 | -           | DN15-PN16 1/2" 150 |      |
| XL 25.50             | 72         | 186               | 12                   | 15  | 0,75 | -           | DN20-PN16 3/4" 150 |      |
| XL 25.50             | 96         | 258               | 12                   | 15  | 0,75 | -           | DN25-PN16 1" 150   |      |
| XL 25.50             | 121        | 312               | 12                   | 15  | 0,75 | -           | DN25-PN16 1" 150   |      |
| XL 25.50             | 144        | 384               | 11                   | 14  | 0,75 | -           | DN25-PN16 1" 150   |      |
| XL 25.50             | 168        | 444               | 10                   | 13  | 0,75 | -           | DN25-PN16 1" 150   |      |

< XL pump with single diaphragm and moulded glass fibre reinforced PP wetted parts. Automatic adjustment of the flow rate via OBL-designed electrical (IP66 as STD). The robustness of the PP wetted parts allows dosing of any chemicals where AISI 316L would be unsuitable, at a working pressure up to 12 bar g. With the same pump head, combining metallic seats and balls (AISI 316L, incoloy 825, Hastelloy C 276 ®), it is possible to offer premium quality/price versions for dosing problematic chemicals such as 50% caustic, viscous polymers and concentrated sulphuric acid.

### OVERALL DIMENSIONS

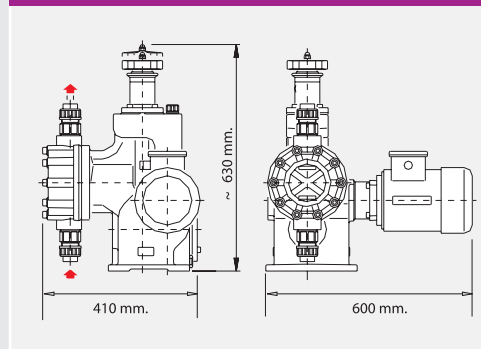

### MATERIALS OF CONSTRUCTION

| PARTS         | PP    | PP11      | PP32            | MA MMA    | MP MMP | MS MMS |
|---------------|-------|-----------|-----------------|-----------|--------|--------|
| LIQUID END    | PP    | PP        | PP              | AISI 316L | PVC    | PVDF   |
| DIAPHRAGM     | PTFE  | PTFE      | PTFE            | PTFE      | PTFE   | PTFE   |
| VALVE SEAT    | PVC   | AISI 316L | INCOLOY 825     | AISI 316L | PVC    | PVDF   |
| VALVE GUIDE   | PP    | PP        | PP              | AISI 316L | PP     | PVDF   |
| VALVE         | PIREX | AISI 316L | HASTELLOY C 276 | AISI 316L | PIREX  | PIREX  |
| VALVE HOUSING | PP    | PP        | PP              | AISI 316L | PVC    | PVDF   |
| VALVE SEAL    | FPM   | FPM       | FPM             | FPM       | FPM    | FPM    |
| FLANGE        | PVC   | PVC       | PVC             | AISI 316L | PVC    | PVDF   |

### MODEL NUMBER

#### KEY TO SYMBOL

|            |                                 |
|------------|---------------------------------|
| PUMP TYPE  |                                 |
| ø PLUNGER  |                                 |
| PP         | PP EXECUTION                    |
| PP11       | PP+AISI-316L VALVE & VALVE SEAT |
| Z          | 4÷20 mA OBL ELECTRIC ACTUATOR   |
| W          | 0,2-1 BAR PNEUMATIC ACTUATOR    |
| ...        | THREADED CONNECTIONS            |
| F          | UNI-DIN FLANGED CONNECTIONS     |
| FA         | ANSI FLANGED CONNECTIONS        |
| N*         | STROKES PER MINUTE              |
| STROKE mm. |                                 |

XL 25 50 PP 120 F Z

# XLB

|                       |  |
|-----------------------|--|
| <b>Pump:</b>          | • Single and multiple  |
| <b>Max flow rate:</b> | • 430 L/h  |
| <b>Max pressure:</b>  | • 40 bar   |
| <b>Motors:</b>        | • Threephase 0,75 kW - 1,5 kW<br>230/400 V - 50/60Hz - 4 poles<br>IP55 - CLF - IEC38 |
| <b>Stroke :</b>       | • 15/25mm  |
| <b>Materials :</b>    | • Cast iron pump body  |
| <b>Weigth :</b>       | • 60÷70 Kgs  |



430 l/h 40 bar

API 675

XLB hydraulic diaphragm positive return pump, suitable for industrial process applications; heavy duty mechanism for operating pressures up to 35 bar, suitable for 24h/7 duties.

- Hydraulic diaphragm metering pump both single and double
- Threaded (BSP female) or flanged connections (both DIN or ANSI)
- Fully conforming with API 675 STD
- Fully conforming with ATEX 94/9/CE, 1/21 and 2/22 zone of danger. Suitable for flammable chemicals thanks to the double diaphragm system
- AISI 316L, PVC e PVDF wetted parts (with single and double diaphragm design)
- With AISI 316L and PVDF wetted parts up to 60 °C pumping temperature
- With PVC wetted parts up to 40 °C pumping temperature



< Three-headed XLB pump with AISI 316L wetted parts.

## Technical characteristics

< XLB single hydraulic diaphragm pump head with AISI 316L wetted parts and ANSI # 300 RF flanged connections.

Max pressure up to 30 bar g.

| TYPE             | STROKES/1' | MAX FLOW RATE I/H | PVS SET PRESS. bar g |     |         |      |        |      | CONNECTIONS |           |          |
|------------------|------------|-------------------|----------------------|-----|---------|------|--------|------|-------------|-----------|----------|
|                  |            |                   | 0,37 kW              |     | 0,75 kW |      | 1,5 kW |      | THREADED    | FLANGED   |          |
|                  |            |                   | W.PRES               | PSV | W.PRES  | PSV  | W.PRES | PSV  |             | UNI       | ANSI     |
| <b>50 Hz</b>     |            |                   |                      |     |         |      |        |      |             |           |          |
| <b>MA - MMA</b>  |            |                   |                      |     |         |      |        |      |             |           |          |
| <b>XLB 15.50</b> | 40         | 63                | 12                   | 15  | 35      | 40   | -      | -    | 1 1/2" BSPF | DN15-PN40 | 1/2" 300 |
| <b>XLB 25.50</b> | 40         | 105               | 12                   | 15  | 35      | 40   | -      | -    | 1 1/2" BSPF | DN15-PN40 | 1/2" 300 |
| <b>XLB 25.50</b> | 60         | 155               | 12                   | 15  | 25      | 30   | -      | -    | 1 1/2" BSPF | DN20-PN40 | 3/4" 300 |
| <b>XLB 25.50</b> | 82         | 215               | 8                    | 10  | 16      | 20   | 25     | 30   | 1 1/2" BSPF | DN20-PN40 | 3/4" 300 |
| <b>XLB 25.50</b> | 100        | 260               | -                    | -   | 15      | 18   | 25     | 30   | 3/4" BSPF   | DN20-PN40 | 3/4" 300 |
| <b>XLB 25.50</b> | 123        | 320               | -                    | -   | 12      | 15   | 25     | 30   | 3/4" BSPF   | DN20-PN40 | 3/4" 300 |
| <b>XLB 25.50</b> | 140        | 370               | -                    | -   | 11      | 14   | 20     | 25   | 1" BSPF     | DN25-PN40 | 1" 300   |
| <b>XLB 25.50</b> | 160        | 430               | -                    | -   | 10      | 13   | 16     | 20   | 1" BSPF     | DN25-PN40 | 1" 300   |
| <b>MS - MMS</b>  |            |                   |                      |     |         |      |        |      |             |           |          |
| <b>XLB 15.50</b> | 40         | 63                | 12                   | 15  | 15      | 18,5 | -      | -    | -           | DN15-PN25 | 1/2" 150 |
| <b>XLB 25.50</b> | 40         | 105               | 12                   | 15  | 15      | 18,8 | -      | -    | -           | DN15-PN25 | 1/2" 150 |
| <b>XLB 25.50</b> | 60         | 155               | 12                   | 15  | 15      | 18,5 | -      | -    | -           | DN20-PN25 | 3/4" 150 |
| <b>XLB 25.50</b> | 82         | 215               | 8                    | 10  | 15      | 18,5 | -      | -    | -           | DN20-PN25 | 3/4" 150 |
| <b>XLB 25.50</b> | 100        | 260               | -                    | -   | 15      | 18,5 | -      | -    | -           | DN25-PN25 | 1" 300   |
| <b>XLB 25.50</b> | 123        | 320               | -                    | -   | 12      | 15   | 15     | 18,5 | -           | DN25-PN25 | 1" 300   |
| <b>XLB 25.50</b> | 140        | 370               | -                    | -   | 11      | 14   | 15     | 18,5 | -           | DN25-PN25 | 1" 300   |
| <b>XLB 25.50</b> | 160        | 430               | -                    | -   | 10      | 13   | 15     | 18,5 | -           | DN25-PN25 | 1" 300   |
| <b>60 Hz</b>     |            |                   |                      |     |         |      |        |      |             |           |          |
| <b>MA - MMA</b>  |            |                   |                      |     |         |      |        |      |             |           |          |
| <b>XLB 15.50</b> | 48         | 76                | 12                   | 15  | 35      | 40   | -      | -    | 1 1/2" BSPF | DN15-PN40 | 1/2" 300 |
| <b>XLB 25.50</b> | 48         | 126               | 12                   | 15  | 35      | 40   | -      | -    | 1 1/2" BSPF | DN15-PN40 | 1/2" 300 |
| <b>XLB 25.50</b> | 72         | 186               | 12                   | 15  | 18      | 22   | 25     | 30   | 1 1/2" BSPF | DN20-PN40 | 3/4" 300 |
| <b>XLB 25.50</b> | 96         | 258               | -                    | -   | 15      | 18   | 25     | 30   | 3/4" BSPF   | DN20-PN40 | 3/4" 300 |
| <b>XLB 25.50</b> | 121        | 312               | -                    | -   | 12      | 15   | 25     | 30   | 3/4" BSPF   | DN20-PN40 | 3/4" 300 |
| <b>XLB 25.50</b> | 144        | 384               | -                    | -   | 11      | 14   | 20     | 25   | 1" BSPF     | DN25-PN40 | 1" 300   |
| <b>XLB 25.50</b> | 168        | 444               | -                    | -   | 10      | 12   | 16     | 20   | 1" BSPF     | DN25-PN40 | 1" 300   |
| <b>MS - MMS</b>  |            |                   |                      |     |         |      |        |      |             |           |          |
| <b>XLB 15.50</b> | 48         | 76                | 12                   | 15  | 15      | 18,5 | -      | -    | -           | DN15-PN25 | 1/2" 150 |
| <b>XLB 25.50</b> | 48         | 126               | 12                   | 15  | 15      | 18,5 | -      | -    | -           | DN15-PN25 | 1/2" 150 |
| <b>XLB 25.50</b> | 72         | 186               | 12                   | 15  | 15      | 18,5 | -      | -    | -           | DN20-PN25 | 3/4" 150 |
| <b>XLB 25.50</b> | 96         | 258               | -                    | -   | 15      | 18,5 | -      | -    | -           | DN25-PN25 | 1" 150   |
| <b>XLB 25.50</b> | 121        | 312               | -                    | -   | 12      | 15   | 15     | 18,5 | -           | DN25-PN25 | 1" 150   |
| <b>XLB 25.50</b> | 144        | 384               | -                    | -   | 11      | 14   | 15     | 18,5 | -           | DN25-PN25 | 1" 150   |
| <b>XLB 25.50</b> | 168        | 444               | -                    | -   | 10      | 12   | 15     | 18,5 | -           | DN25-PN25 | 1" 150   |

< XLB metering pump with ANSI # 300 RF flanged connections (max pressure up to 30 bar g), double hydraulic diaphragm, AISI 316L wetted parts and visual rupture detector via pressure gauge. Pump fully conforms to ATEX 94/9/CE and API STD 675.



### OVERALL DIMENSIONS

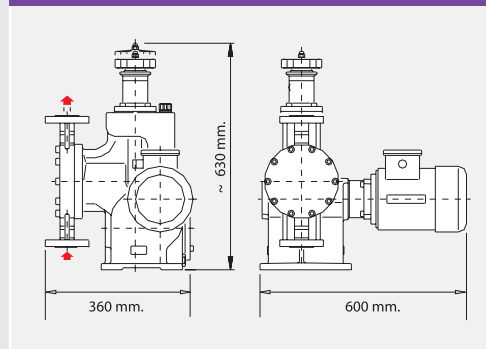

### MATERIALS OF CONSTRUCTION

| PARTS         | MA/MMA    | MS/MMS |
|---------------|-----------|--------|
| LIQUID END    | AISI 316L | PVDF   |
| DIAPHRAGM     | PTFE      | PTFE   |
| VALVE SEAT    | AISI 316L | PVDF   |
| VALVE GUIDE   | AISI 316L | PVDF   |
| VALVE         | AISI 316L | PIREX  |
| VALVE HOUSING | AISI 316L | PVDF   |
| VALVE SEAL    | FPM       | FPM    |
| FLANGE        | AISI 316L | PVDF   |

### MODEL NUMBER

#### KEY TO SYMBOL

|           |                               |
|-----------|-------------------------------|
| PUMP TYPE |                               |
| ø PLUNGER |                               |
| MA        | AISI 316L EXECUTION           |
| MS        | PVDF EXECUTION                |
| Z         | 4÷20 mA OBL ELECTRIC ACTUATOR |
| W         | 0,2-1 BAR PNEUMATIC ACTUATOR  |
| ...       | THREADED CONNECTIONS          |
| F         | UNI-DIN FLANGED CONNECTIONS   |
| FA        | ANSI FLANGED CONNECTIONS      |
| N*        | STROKES PER MINUTE            |
|           | STROKE mm.                    |

**XLB 25 50 MA 120 FA Z**

|                       |   |
|-----------------------|---|
| <b>Pump:</b>          | • Single and multiple   |
| <b>Max flow rate:</b> | • 1500 L/h  |
| <b>Max pressure:</b>  | • 20 bar  |
| <b>Motors:</b>        | • Trifase 0,75 kW - 1,5 kW - 2,2 kW<br>230/400 V - 50/60Hz - 4 poli<br>IP55 - CLF - IEC38 |
| <b>Stroke :</b>       | • 44,5 mm   |
| <b>Materials:</b>     | • Cast iron pump body   |
| <b>Weigth :</b>       | • 170 Kgs   |



1500 l/h 20 bar

# API 675

XLC pumps have high STD basic version: flanged connections and double diaphragm with local visual rupture detection via pressure gauge, suitable for dangerous toxic, flammable and even explosive chemicals. XLC pumps are suitable for 24/7 industrial applications.

- Double hydraulic diaphragm metering pumps
- Flanged connections only (either DIN or ANSI)
- Fully conforming with API 675 STD
- Fully conforming with ATEX 94/9/CE, 1/21 and 2/22 zone of danger. Suitable for flammable chemicals thanks to the double diaphragm system
- AISI 316L, PVC e PVDF wetted parts
- With AISI 316L and PVDF wetted parts up to 75 °C pumping temperature
- With PVC wetted parts up to 40 °C pumping temperature



< XLC PVC basic version with:  
double diaphragm with local visual  
rupture detector and flanged con-  
nections.



## Technical characteristics

< XLC pump with double hydraulic diaphragm, rupture detector via both pressure gauge and pressure switch (local/remote).

AISI 316L/PTFE wetted materials only and threaded connection to DIN 11851.

| TYPE             | STROKES/1' | MAX FLOW RATE I/H | MAX PRESSURE - PVS SET PRESS. bar g |        |        | FLANGED CONNECTIONS |              |
|------------------|------------|-------------------|-------------------------------------|--------|--------|---------------------|--------------|
|                  |            |                   | 0,75 kW                             | 1,5 kW | 2,2 kW | UNI                 | ANSI         |
| <b>50 Hz</b>     |            |                   |                                     |        |        |                     |              |
| <b>AISI 316L</b> |            |                   |                                     |        |        |                     |              |
| XLC A            | 40         | 350               | 14                                  | 20     | 20     | DN 25               | 1" 300RF     |
| XLC A            | 60         | 550               | 10                                  | 20     | 20     | DN 25               | 1" 300RF     |
| XLC A            | 82         | 750               | 8                                   | 17     | 20     | DN 40               | 1 1/2" 300RF |
| XLC A            | 100        | 920               | 6                                   | 12     | 17     | DN 40               | 1 1/2" 150RF |
| XLC A            | 123        | 1150              | -                                   | 10     | 15     | DN 40               | 1 1/2" 150RF |
| XLC A            | 140        | 1300              | -                                   | 8      | 12     | DN 40               | 1 1/2" 150RF |
| XLC A            | 160        | 1500              | -                                   | 6      | 12     | DN 40               | 1 1/2" 150RF |
| <b>PVC</b>       |            |                   |                                     |        |        |                     |              |
| XLC P            | 40         | 350               | 12                                  | 12     | -      | DN 25               | 1" 150RF     |
| XLC P            | 60         | 550               | 10                                  | 12     | -      | DN 25               | 1" 150RF     |
| XLC P            | 82         | 750               | 8                                   | 12     | -      | DN 40               | 2" 150RF     |
| XLC P            | 100        | 920               | 6                                   | 12     | 12     | DN 40               | 2" 150RF     |
| XLC P            | 123        | 1150              | -                                   | 10     | 12     | DN 40               | 2" 150RF     |
| XLC P            | 140        | 1300              | -                                   | 8      | 12     | DN 40               | 2" 150RF     |
| XLC P            | 160        | 1500              | -                                   | 6      | 12     | DN 40               | 2" 150RF     |
| <b>PVDF</b>      |            |                   |                                     |        |        |                     |              |
| XLC S            | 40         | 350               | 14                                  | 18,5   | -      | DN 25               | 1" 150RF     |
| XLC S            | 60         | 550               | 10                                  | 18,5   | -      | DN 25               | 1" 150RF     |
| XLC S            | 82         | 750               | 8                                   | 17     | 18,5   | DN 40               | 2" 150RF     |
| XLC S            | 100        | 920               | 6                                   | 12     | 17     | DN 40               | 2" 150RF     |
| XLC S            | 123        | 1150              | -                                   | 10     | 15     | DN 40               | 2" 150RF     |
| XLC S            | 140        | 1300              | -                                   | 8      | 12     | DN 40               | 2" 150RF     |
| XLC S            | 160        | 1500              | -                                   | 6      | 12     | DN 40               | 2" 150RF     |
| <b>60 Hz</b>     |            |                   |                                     |        |        |                     |              |
| <b>AISI 316L</b> |            |                   |                                     |        |        |                     |              |
| XLC A            | 48         | 420               | 13                                  | 20     | 20     | DN 25               | 1" 300RF     |
| XLC A            | 72         | 660               | 10                                  | 17     | 20     | DN 25               | 1" 300RF     |
| XLC A            | 96         | 900               | 6                                   | 12     | 17     | DN 40               | 1 1/2" 300RF |
| XLC A            | 121        | 1150              | -                                   | 10     | 15     | DN 40               | 1 1/2" 150RF |
| XLC A            | 144        | 1300              | -                                   | 8      | 12     | DN 40               | 1 1/2" 150RF |
| XLC A            | 165        | 1540              | -                                   | 6      | 12     | DN 40               | 1 1/2" 150RF |
| <b>PVC</b>       |            |                   |                                     |        |        |                     |              |
| XLC P            | 48         | 420               | 12                                  | 12     | -      | DN 25               | 1" 150RF     |
| XLC P            | 72         | 660               | 10                                  | 12     | -      | DN 25               | 1" 150RF     |
| XLC P            | 96         | 900               | 6                                   | 12     | 12     | DN 40               | 2" 150RF     |
| XLC P            | 121        | 1150              | -                                   | 10     | 12     | DN 40               | 2" 150RF     |
| XLC P            | 144        | 1300              | -                                   | 8      | 12     | DN 40               | 2" 150RF     |
| XLC P            | 165        | 1540              | -                                   | 6      | 12     | DN 40               | 2" 150RF     |
| <b>PVDF</b>      |            |                   |                                     |        |        |                     |              |
| XLC S            | 48         | 420               | 12                                  | 18,5   | -      | DN 25               | 1" 150RF     |
| XLC S            | 72         | 660               | 10                                  | 18,5   | -      | DN 25               | 1" 150RF     |
| XLC S            | 96         | 900               | 6                                   | 12     | 17     | DN 40               | 2" 150RF     |
| XLC S            | 121        | 1150              | -                                   | 10     | 15     | DN 40               | 2" 150RF     |
| XLC S            | 144        | 1300              | -                                   | 8      | 12     | DN 40               | 2" 150RF     |
| XLC S            | 165        | 1540              | -                                   | 6      | 12     | DN 40               | 2" 150RF     |

< XLC AISI 316L basic version with: double diaphragm with local visual rupture detector and flanged connections.

### OVERALL DIMENSIONS

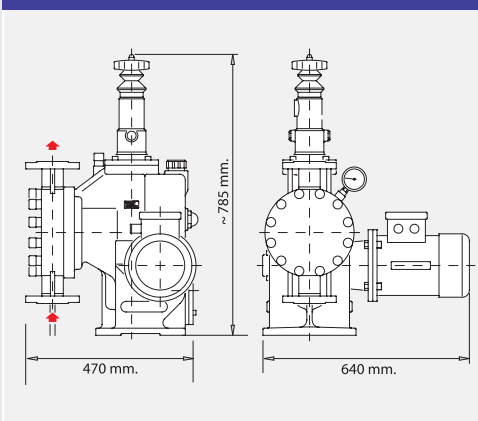

### MATERIALS OF CONSTRUCTION

| PARTS         | A         | P     | S     |
|---------------|-----------|-------|-------|
| LIQUID END    | AISI 316L | PVC   | PVDF  |
| DIAPHRAGM     | PTFE      | PTFE  | PTFE  |
| VALVE SEAT    | AISI 316L | PVC   | PVDF  |
| VALVE GUIDE   | AISI 316L | PP    | PVDF  |
| VALVE         | AISI 316L | PIREX | PIREX |
| VALVE HOUSING | AISI 316L | PVC   | PVDF  |
| VALVE SEAL    | FPM       | FPM   | FPM   |
| FLANGE        | AISI 316L | PVC   | PVDF  |

### MODEL NUMBER

#### KEY TO SYMBOL

#### PUMP TYPE

|     |   |
|-----|---|
| A   | AISI 316L EXECUTION                                   |
| P   | PVC EXECUTION   |
| S   | PVDF EXECUTION  |
| Z   | 4÷20 mA OBL ELECTRIC ACTUATOR                         |
| W   | 0,2-1 BAR PNEUMATIC ACTUATOR                          |
| ... | UNI/DIN FLANGED CONNECTIONS                           |
| FA  | ANSI FLANGED CONNECTIONS<br>MEMBRANE RUPTURE DETECTOR |
| N°  | STROKES PER MINUTE                                    |

XLC A 123 S... FA Z

## Control systems

Automatic adjustments

### Z type electrical actuator >

**XL/XLB/XLC** can be equipped with Z type electrical actuator, with following characteristics:

- IP 66 STD
- Manual emergency override
- Anticondensation heater (on demand)
- Non standard voltages and frequencies
- External automatic/manual selector

Flow rate is adjusted according to following input signals:

- 4-20 mA, 0-20 A, 20-4 mA e 0-10 V
- Pulses (0÷2 Hz - 0÷30 Hz)
- RS 485 protocol
- PROFIBUS DP - VØ



### Electrical actuator >

- ATEX II 2GD EEx-d IIB T4 IP6X
- 115/230V - 1 - 50/60 Hz
- 230/400V - 3 - 50/60 Hz
- 4-20 mA signal and feedback
- Manual emergency override
- Anticondensation heater (on demand)



### W type pneumatic actuator >

- ATEX II 2G c IIC T6
- Pneumatic actuator type WA.
- Air instrument 3÷15 PSI
- Air supply 4-6 bar
- Emergency manual override



### Knob >

- Micrometer control reading 0-100%.
- 0,1% steps sealed magnifying lens indicator.



DosingPump.ir

Manual adjustment

## References

| Year | End user / contractor / Customer   | Application                          | Country           |
|------|--|--------------------------------------|-------------------|
| 2002 | Consortium Enel-Power Hitachi Zosen  | Power and desalination plant         | Oman              |
| 2003 | ICAP-SIRA chemicals and polymers   | Chemical injection unit              | Italy             |
| 2003 | AKZO Nobel AB / ETEK pilot plant   | Biodiesel production                 | Sweden            |
| 2003 | Kellogs Brown & Root / South Oil Co.   | Petrochemical                        | Iraq              |
| 2004 | SIEMENS Power Generation   | Demineralisation plant               | Saudi Arabia      |
| 2004 | West Delta Electricity production company<br>Nubaria power plant                                 | Power station                        | Egypt             |
| 2004 | Nan Ya Plastic Corporation   | Chemical plant                       | Taiwan            |
| 2004 | Formosa plastic corporation  | PVC production                       | Taiwan            |
| 2004 | Bechtel Marathon Oil Company Albas Phase 3 Project<br>Bioko Island                               | On-shore Oil & Gas                   | Equatorial Guinea |
| 2005 | Doosan Heavy Industries and Construction Co. Ltd.<br>Sohar Independent Water and power project   | Desalination plant                   | Oman              |
| 2005 | Jordan Petroleum Refinery Co. Ltd. / Amman Refinery  | Petrochemical                        | Jordan            |
| 2005 | Nan Ya Plastic Corporation   | Chemical plant                       | Taiwan            |
| 2005 | Chanchun Petrochemical Co.   | Chemical plant                       | Taiwan            |
| 2005 | Formosa Petrochemical Corp.  | Chemical plant                       | Taiwan            |
| 2005 | ENI S.p.A.   | Petrochemical                        | Italy             |
| 2005 | Toyo Thai Corp Ltd / Vinithai Public Company   | Petrochemical plant                  | Thailand          |
| 2006 | Kellog Brown and Root SVCS Inc.<br>North Rumaylah NGL Plant                                      | Demineralisation plant               | Iraq              |
| 2006 | Bechtel -Abu Dhabi Gas Industries Ltd (GASCO)<br>ASAB Gas Development Phase II (AGD-II)          | Waste water treatment gas field      | UAE               |
| 2007 | ADWEC / Al Taweelah B Abu Dhabi  | Waste water treatment                | UAE               |
| 2007 | UTE Desaladora Skikda Construction   | Desalination plant                   | Algeria           |
| 2007 | Uniens Co. Ltd   | Waste water treatment                | Vietnam           |
| 2007 | Desmet Ballestra   | Biodiesel plant                      | Spain             |
| 2007 | Erg Raffinerie Mediterranee S.p.A.   | Refinery                             | Italy             |
| 2007 | Takreer / Inter Refinery pipelines injection   | Refinery                             | UAE               |
| 2008 | Qatar Electricity Water Co / Fisia Italimpianti  | Power plant                          | Qatar             |
| 2008 | PEQUIVEN (Petroquimica de Venezuela)   | Phosphate recovery from rocks        | Venezuela         |
| 2008 | Desmet Ballestra   | Biodiesel plant                      | Spain             |
| 2008 | S.C. TERMICA -SUCEAVA  | Power station                        | Romania           |
| 2008 | TECNIMONT-Maire  | Coke power plant                     | Chile             |
| 2008 | Qatalum (joint venture Qatar Petroleum and<br>Norsk Hydro ASA), SPIG Italy                       | Cooling tower                        | Qatar             |
| 2008 | Fisia Italimpianti / Dubai Electricity and Water Authority<br>Jebel Ali "M" station, package "D" | Power and water - Water desalination | UAE               |
| 2009 | Ittehad Chemicals Ltd  | Inorganic chemical production        | Pakistan          |
| 2009 | Petrobras Brasil   | Oil & Gas                            | Brazil            |
| 2009 | Bayer Technology and Engineering   | Petrochemical                        | China             |
| 2009 | Refineria La Teja ANCAP, YPF   | Petrochemical                        | Uruguay           |
| 2010 | GE West Delta Electricity production Co Ltd  | Power plant                          | Egypt             |
| 2011 | Achinsky Refinery  | Refinery                             | Russia            |
| 2011 | Motor Oil Hellas Corinth Refineries S.A.   | Refinery                             | Greece            |

Technical data are subject to modifications without prior notice.



Quality System ISO 9001 Certified

An IDEX Water & Wastewater Business. 

**OBL s.r.l.**

20090 Segrate - MILANO

Via Kennedy, 12

Tel. +39-02.269191

Fax +39-02.2133893

[www.oblitalia.com](http://www.oblitalia.com)

[obl.info@idexcorp.com](mailto:obl.info@idexcorp.com)

DosingPump.ir