

Motor-driven Metering Pump
alpha ALPc

EN

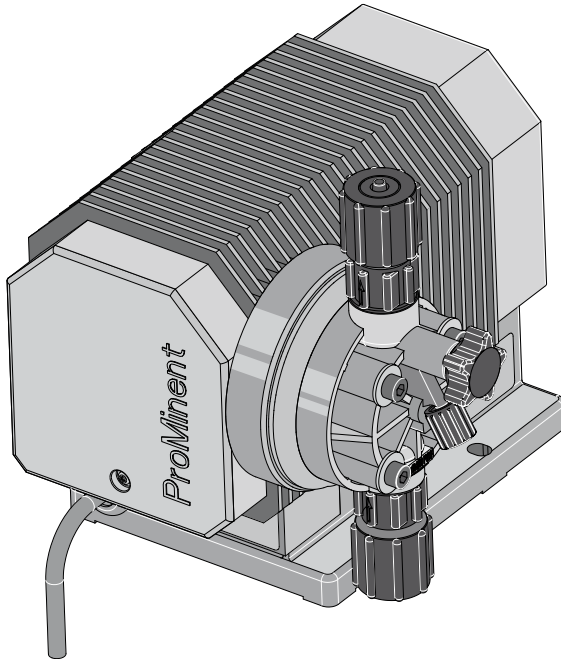

Please carefully read these operating instructions before use. · Do not discard.
The operator shall be liable for any damage caused by installation or operating errors.
The latest version of the operating instructions are available on our homepage.

Supplementary information



Fig. 1: Please read!

Read the following supplementary information in its entirety! You will benefit more from using the operating instructions should you already know this information.

The following are highlighted separately in the document:

- Enumerated lists
- ➔ Instructions
- ⇒ Outcome of the instructions

🔗 *'State the identity code and serial number'* on page 2. Links to points in this chapter

- refer to ... : References to points in this document or another document

[Keys]

Information



This provides important information relating to the correct operation of the unit or is intended to make your work easier.

Safety Information

Safety information is identified by pictograms - see Safety Chapter.

Validity

These operating instructions conform to current EU regulations applicable at the time of publication.

State the identity code and serial number

Please state identity code and serial number, which you can find on the nameplate when you contact us or order spare parts. This enables us to clearly identify the unit type and material versions.

DosingPump.ir

Table of contents

1	Identity code	5
2	Safety chapter	7
3	Storage, Transport and Unpacking	12
4	Overview of equipment	13
5	Functional description	14
	5.1 Power end.....	14
	5.2 Liquid End.....	14
6	Assembly	15
7	Installation, hydraulic	16
	7.1 Installing hose lines.....	17
	7.1.1 Installation of the suction and discharge line.....	17
	7.1.2 Installation of metering pumps with bleed valve.....	20
	7.1.3 Basic installation notes.....	20
8	Electrical installation	23
9	Start up	24
10	Maintenance	28
11	Repairs	31
	11.1 Cleaning valves.....	31
	11.2 Replacing the diaphragm.....	32
	11.3 Replacing the complete dosing head.....	36
12	Troubleshooting	37
	12.1 Faults and troubleshooting.....	38
	12.2 All other faults.....	39
13	Decommissioning and disposal	40
	13.1 Decommissioning.....	40
	13.2 Disposal.....	41
14	Technical data	42
15	Design Documents	46
16	Dimensional drawings	47
17	Further order information	48

DosingPump.ir

Table of contents

18	Declaration of Conformity for Machinery.....	49
----	--	----

DosingPump.ir

1 Identity code

alpha product range, version c

ALPc	Type	Capacity	
		bar	l/h (at 50 Hz)
	1001	10	0.9
	1002	10	1.8
	1004	10	3.5
	1008	10	7.7
	0707	7	6.9
	0417	4	17.0
	0230	2	29.7
		Dosing head material	
		PPE	PP/PP/EPDM
		PPB	PP/PP/FPM-B
		NPE	Clear acrylic/PVC//EPDM
		NPE	Clear acrylic/PVC/FPM
		PVT	PVDF/PVDF/PTFE
		Seal material	
		2	Without valve spring, with bleed valve
		3	with 2 valve springs (approx. 0.1 bar, material 1.4571), with bleed valve
		Hydraulic connector	
		0	Standard connection in line with technical data
		Design	
		0	with ProMinent logo
		N	modified
		Electrical connection	

Identity code

alpha product range, version c

A	230 V , 50/60 Hz, 2 m European
B	230 V, 50/60 Hz, 2 m Swiss
C	230 V, 50/60 Hz, 2 m Australian
D	115 V , 50/60 Hz, 2 m USA
Accessories	
0	no accessories
1	with foot and injection valve, 2 m PVC suction line, 5 m metering line

DosingPump.ir

2 Safety chapter



Identification of safety notes

The following signal words are used in these operating instructions to denote different severities of danger:

Signal word	Meaning
WARNING	Denotes a possibly dangerous situation. If this is disregarded, you are in a life-threatening situation and this can result in serious injuries.
CAUTION	Denotes a possibly dangerous situation. If this is disregarded, it could result in slight or minor injuries or material damage.

Warning signs denoting different types of danger

The following warning signs are used in these operating instructions to denote different types of danger:

Warning signs	Type of danger
	Warning – automatic start-up.
	Warning – hand injuries.
	Warning – high-voltage.

Warning signs	Type of danger
	Warning – danger zone.

Intended use

- Only use the pump to meter liquid feed chemicals.
- Only use the pump after it has been correctly installed and started up in accordance with the technical data and specifications contained in the operating instructions.
- Observe the general limitations with regard to viscosity limits, chemical resistance and density - see also ProMinent® Resistance List in the Product Catalogue or at www.prominent.com!
- All other uses or modifications are prohibited.
- The pump is not intended for the metering of gaseous media and solids.
- The pump is not intended to meter flammable media.
- The pump is not intended for the metering of explosive media.
- The pump is not intended for operation in areas at risk from explosion.
- The pump is not intended for exterior applications without the implementation of suitable protective measures.
- The pump should only be operated by trained and authorised personnel, see the following "Qualifications" table.
- You have a responsibility to adhere to the information contained in the operating instructions at the different phases of the unit's service life.

Qualification of personnel

Action	Qualification
Storage, transport, unpacking	Instructed person
Assembly	Technical personnel, service
Planning hydraulic installation	Qualified personnel who have a thorough knowledge of metering pumps.
Hydraulic installation	Technical personnel, service
Installation, electrical	Electrical technician
Operation	Instructed person
Maintenance, repair	Technical personnel, service
Decommissioning, disposal	Technical personnel, service
Troubleshooting	Technical personnel, electrical technician, instructed person, service

Explanation of the terms:

Technical personnel

A qualified employee is deemed to be a person who is able to assess the tasks assigned to him and recognise possible dangers based on his/her technical training, knowledge and experience, as well as knowledge of pertinent regulations.

Note:

A qualification of equal validity to a technical qualification can also be gained by several years employment in the relevant work area.

Electrical technician

Electrical technicians are deemed to be people, who are able to complete work on electrical systems and recognise and avoid possible dangers independently based on their technical training and experience, as well as knowledge of pertinent standards and regulations.

Electrical technicians should be specifically trained for the working environment in which they are employed and know the relevant standards and regulations.

Electrical technicians must comply with the provisions of the applicable statutory directives on accident prevention.

Instructed person

An instructed person is deemed to be a person who has been instructed and, if required, trained in the tasks assigned to him/her and possible dangers that could result from improper behaviour, as well as having been instructed in the required protective equipment and protective measures.

Service

Customer Service department refers to service technicians, who have received proven training and have been authorised by ProMinent or ProMaqua to work on the system.

Safety information



WARNING!

Warning about personal and material damage

The pump can start to pump, as soon as it is connected to the mains voltage.

- Install an emergency cut-off switch in the pump power supply line or integrate the pump in the emergency cut-off management of the system.



WARNING!

Danger of electric shock

A mains voltage may exist inside the pump housing.

- If the pump housing has been damaged, you must disconnect it from the mains immediately. It may only be returned to service after an authorised repair.



WARNING!

Warning of hazardous feed chemical

Should a dangerous feed chemical be used: it may escape from the hydraulic components when working on the pump, material failure or incorrect handling of the pump.

- Take appropriate protective measures before working on the pump (e.g. safety glasses, safety gloves, ...). Adhere to the material safety data sheet for the feed chemical.
- Drain and flush the liquid end before working on the pump.



WARNING!

Danger from hazardous substances!

Possible consequence: Fatal or very serious injuries.

Please ensure when handling hazardous substances that you have read the latest safety data sheets provided by the manufacture of the hazardous substance. The actions required are described in the safety data sheet. Check the safety data sheet regularly and replace, if necessary, as the hazard potential of a substance can be re-evaluated at any time based on new findings.

The system operator is responsible for ensuring that these safety data sheets are available and that they are kept up to date, as well as for producing an associated hazard assessment for the workstations affected.

DosingPump.ir

CAUTION!

Warning of feed chemical spraying around

Feed chemical can spray out of the hydraulic components if they are manipulated or opened due to pressure in the liquid end and adjacent parts of the system.

- Disconnect the pump from the mains power supply and ensure that it cannot be switched on again by unauthorised persons.
- Depressurise the system before commencing any work on hydraulic parts.

CAUTION!

Warning of feed chemical spraying around

An unsuitable feed chemical can damage the parts of the pump that come into contact with the chemical.

- Take into account the resistance of the wetted materials and the ProMinent Resistance List when selecting the feed chemical - see the ProMinent Product Catalogue or visit ProMinent.

CAUTION!

Warning of feed chemical spraying around

The metering pump can generate a multiple of its rated pressure. Hydraulic parts can rupture if a discharge line is blocked.

- Correctly install a relief valve in the discharge line downstream of the metering pump.

CAUTION!

Danger of personnel injury and material damage

The use of untested third party parts can result in personnel injuries and material damage.

- Only fit parts to metering pumps, which have been tested and recommended by ProMinent.

CAUTION!

Danger from incorrectly operated or inadequately maintained pumps

Danger can arise from a poorly accessible pump due to incorrect operation and poor maintenance.

- Ensure that the pump is accessible at all times.
- Adhere to the maintenance intervals.

DosingPump.ir

**CAUTION!****Warning against illegal operation**

Observe the regulations that apply where the device is installed.

Fixed separating protective equipment

- Cover
- Dosing head
- Housing

The customer may only remove the cover to adjust the stroke length.

Customer should only remove the dosing head in accordance with the "Repair" chapter.

Only the ProMinent Service department are authorised to remove the housing.

Ensure that all protective equipment is properly fitted before the pump is operated.

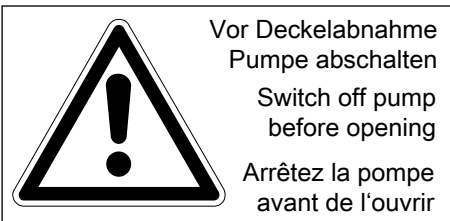
Other safety equipment

P_ALP_0010_SW

Fig. 2

Ensure that the warning label is always fitted and legible.

Circuit breaker

The driver motor is fitted with a circuit breaker, which automatically switches off the motor when it overheats to more than 106 °C.

The circuit breaker switches the pump on again once the motor has cooled down.

Information in the event of an emergency

In an emergency, either pull out the mains plug or press the emergency-off switch, installed by the customer, or disconnect the pump in line with the emergency-shut-down guidelines for your system!

If feed chemical escapes, also ensure that the pump's hydraulic environment is at atmospheric pressure. Adhere to the material safety data sheet for the feed chemical.

Sound pressure level

Sound pressure level LpA < 70 dB according to EN ISO 20361

at maximum stroke length, maximum stroke rate, maximum back pressure (water)

DosingPump.ir

3 Storage, Transport and Unpacking

Safety Information

 **WARNING!**

Only return metering pumps for repair in a cleaned state and with a flushed liquid end - refer to "Decommissioning!"

Only return metering pumps with a completed Decontamination Declaration form. The Decontamination Declaration constitutes an integral part of an inspection / repair order. A unit can only be inspected or repaired when a Declaration of Decontamination Form is submitted that has been completed correctly and in full by an authorised and qualified person on behalf of the pump operator.

The "Decontamination Declaration Form" can be found on our homepage.

 **CAUTION!****Danger of material damage**

The device can be damaged by incorrect or improper storage or transportation!

- The unit should only be stored or transported in a well packaged state - preferably in its original packaging.
- The packaged unit should also only be stored or transported in accordance with the stipulated storage conditions.
- The packaged unit should be protected from moisture and the ingress of chemicals.

Ambient conditions

Ambient conditions - refer to "Technical Data" chapter.

Scope of delivery

Compare the delivery note with the scope of delivery:

- Metering pump with mains cable
- Connector kit for hose/pipe connection
- Product-specific operating instructions with Declaration of Conformity

DosingPump.ir

4 Overview of equipment

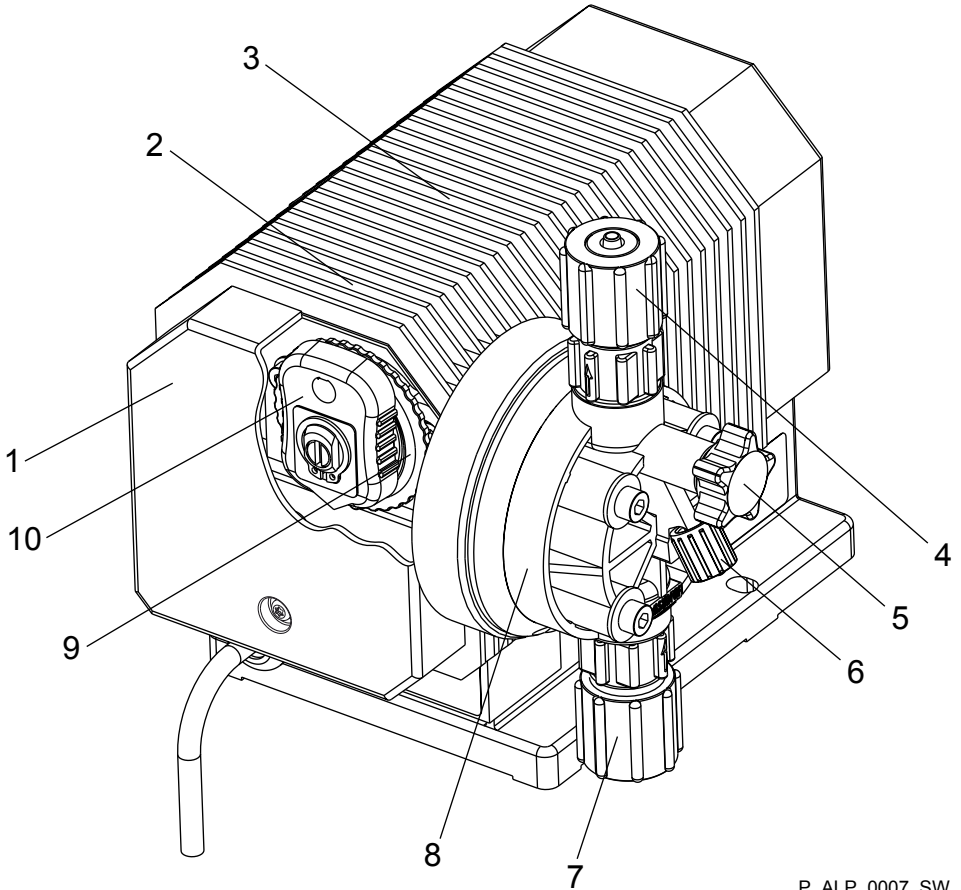

P_ALP_0007_SW

Fig. 3

- | | | | |
|---|--------------------|----|---------------------------|
| 1 | Cover | 6 | Bypass hose nozzle |
| 2 | Motor mounting | 7 | Suction connector |
| 3 | Housing | 8 | Dosing head |
| 4 | Pressure connector | 9 | Eccentric disc with scale |
| 5 | Bleed valve | 10 | Latched slide |

DosingPump.ir

5 Functional description

5.1 Power end

The cam for the stroke movement is guided in an eccentric disc. Pumps of this size do not therefore require conventional return springs – the suction and pressure stroke are positively driven.

The stroke length can be adjusted by a latched slide (9) from 100% to 0 in increments of 10%. The diaphragm is always deflected from the neutral centre position, producing a smooth sinusoidal stroke motion.

5.2 Liquid End

The dosing process is performed as follows:
The diaphragm is pressed into the dosing head; the pressure in the dosing head closes the suction valve and the feed chemical flows through the discharge valve out of the dosing head. The diaphragm is now drawn out of the dosing head; the discharge valve closes due to the negative pressure in the dosing head and fresh feed chemical flows through the suction valve into the dosing head. One cycle is completed.

DosingPump.ir

6 Assembly



WARNING!

The IP 23 protection against moisture and accidental contact only applies to horizontal pump bases with vertically installed pumps.



CAUTION!

When assembling the pump, ensure that there is sufficient room around the pump for operation, maintenance, repairs and quick disconnection of the mains plug.



Capacity too low

Vibrations can disturb the liquid end valves.

- *Secure the metering pump to ensure that no vibrations can occur.*



Capacity too low

If the liquid end valves are not upright, they cannot close correctly.

- *Ensure that the discharge valve is upright.*

- ➔ Assemble the metering pump on a storage tank or a bracket using screws and U-washers (Ø 5 mm).

DosingPump.ir

7 Installation, hydraulic

Safety notes

 **CAUTION!****Warning of feed chemical spraying around**

An unsuitable feed chemical can damage the parts of the pump contacted by the chemical.

- Take into account the resistance of the materials which will come into contact with the chemical when selecting the feed chemical - see the ProMinent Product Catalogue or visit www.prominent.com.

 **CAUTION!****Warning of feed chemical spraying around**

Pumps which are not fully installed hydraulically can pump feed chemical from the outlet opening of the discharge valve as soon as they are connected to the mains power supply.

- First install the pump hydraulically, then electrically.
- In the event that you have failed to do so, press the On/Off switch (on site) or the Emergency Stop switch.

 **CAUTION!****Warning of feed chemical spraying around**

Feed chemical can spray out of the hydraulic components if they are manipulated or opened due to pressure in the liquid end and adjacent parts of the system.

- Disconnect the pump from the mains power supply and ensure that it cannot be switched on again by unauthorised persons.
- Depressurise the system before commencing any work on hydraulic parts.

 **CAUTION!****Danger from rupturing hydraulic components**

Peak loads during the dosing stroke can cause the maximum permissible operating pressure of the system and pump to be exceeded.

- The discharge lines are to be properly designed.

DosingPump.ir



CAUTION!

Danger of personnel injury and material damage

The use of untested third party parts can result in personnel injuries and material damage.

- Only fit parts to metering pumps, which have been tested and recommended by ProMinent.



CAUTION!

Danger resulting from rupturing hydraulic components

Hydraulic components can rupture if the maximum permissible operating pressure is exceeded.

- Always adhere to the maximum permissible operating pressure of all hydraulic components - please refer to the product-specific operating instructions and system documentation.
- Never allow the metering pump to run against a closed shut-off device.
- Install a relief valve.

7.1 Installing hose lines

7.1.1 Installation of the suction and discharge line

Safety notes



CAUTION!

Warning of feed chemical spraying around

If the pipes are not installed correctly, they can come loose or burst.

- Route all hose lines so they are free from mechanical stresses and kinks.
- Only use original hoses with the specified hose dimensions and wall thicknesses.
- Only use clamp rings and hose nozzles that are intended for the hose diameter in question to ensure the long service life of the connections.



CAUTION!

Hazardous feed chemicals can escape

Hazardous or extremely aggressive feed chemicals can leak out when using conventional bleeding procedures with metering pumps.

- Install a bleed line with return into the storage tank.

DosingPump.ir



CAUTION!

Hazardous feed chemicals can escape

Hazardous or extremely aggressive feed chemicals can leak out in the event that the metering pump is removed from the installation.

- Install a shut-off valve on the metering pump's pressure and discharge sides.



Align the pipes so that the metering pump and the liquid end can be removed from the side if necessary.



CAUTION!

Uncontrolled flow of feed chemical

Feed chemicals can leak through a stopped metering pump if there is back pressure.

- Use an injection valve or a vacuum breaker.



CAUTION!

Uncontrolled flow of feed chemical

Feed chemicals can leak through the metering pump in an uncontrolled manner in the event of excessive priming pressure.

- Do not exceed the maximum permissible priming pressure for the metering pump.

DosingPump.ir

Installing hose lines

1. ➔ Cut off the ends of the hoses at right angles.
2. ➔ Pull the union nut (20) and clamp ring (21) over the hose (24) - see figure & 'Installing hose lines' on page 18.
3. ➔ Push the hose end (24) up to the stop over the nozzle (4) and widen, if necessary.



Ensure that the O-ring and the flat seal (23) is sitting properly.



Never re-use used PTFE seals. An installation sealed in this way is not watertight.

This type of seal is permanently distorted when subjected to pressure.

4. ➔ Place the hose (24) with the nozzle (22) onto the valve.
5. ➔ Clamp the hose connector: Tighten the union nut (20) while simultaneously pressing on the hose (24).
6. ➔ Re-tighten the hose connector: Pull on the hose (24) briefly, which is fastened to the dosing head and then tighten the union nut (20) once more.

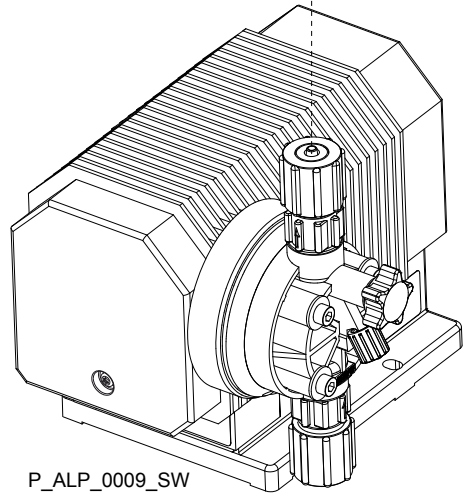
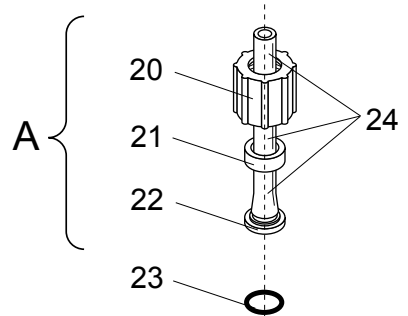

P_ALP_0009_SW

Fig. 4

- A Pressure connector
- 20 Union nut
- 21 Clamp ring
- 22 Nozzle
- 23 O-ring or flat seal
- 24 Hose

7.1.2 Installation of metering pumps with bleed valve

Safety notes



CAUTION!

- All the installation and safety notes for metering pumps without bleed valves also apply.

Installation of the return line

A return line is additionally connected to the suction and discharge line.

1. → Fasten the tube line to the return hose nozzle or to the liquid end bleed valve. PVC hose, soft, 6x4 mm is recommended.
2. → Feed the free end of the return line back to the storage tank.
3. → Shorten the return line so that it does not dip into the feed chemical in the storage tank.

7.1.3 Basic installation notes

Safety notes



CAUTION!

Danger from rupturing hydraulic components

Hydraulic components can rupture if the maximum permissible operating pressure is exceeded.

- Never allow the metering pump to run against a closed shut-off device.
- With metering pumps without integral relief valve Install a relief valve in the discharge line.



CAUTION!

Hazardous feed chemicals can escape

With hazardous feed chemicals Hazardous feed chemicals can leak out when using conventional bleeding procedures with metering pumps.

- Install a bleed line with return into the storage tank.

- Shorten the return line so that it cannot dip into the feed chemical in the storage tank.

DosingPump.ir

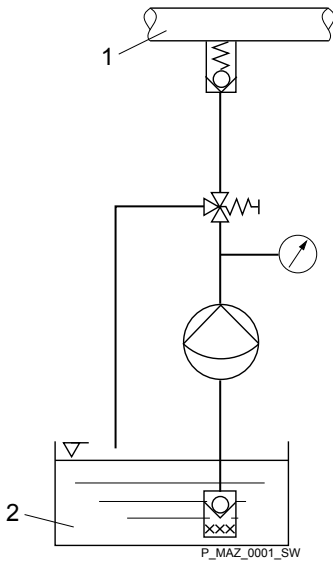







Fig. 5: Standard installation

- 1 Main line
- 2 Storage tank

DosingPump.ir

Legend for hydraulic diagram

Symbol	Explanation	Symbol	Explanation
	Metering pump		Foot valve with mesh
	Injection valve		Level switch
	Multifunctional valve		Manometer

DosingPump.ir

8 Electrical installation



WARNING!

Danger of an electric shock

Only trained and authorised personnel may install the pump.



WARNING!

Danger of electric shock

This pump is supplied with a protective earth conductor and a plug with a protective contact.

- Ensure that it is only connected to a socket with a correctly connected protective contact to reduce the risk of electric shock.



WARNING!

Danger of electric shock

In the event of an electrical accident, quickly disconnect the pump from the mains power supply.

- Install an emergency cut-off switch in the pump power supply line or
- Integrate the pump into the emergency cut-off guidelines for the system and inform personnel of electrical isolating options.



WARNING!

Danger of electric shock

Mains voltage may be present inside the pump housing.

- If the pump housing has been damaged, disconnect it from the mains immediately. Only return the pump to service after it has been repaired by authorised personnel.



CAUTION!

If the pump is integrated into a system: Design the system so that potential hazardous situations are avoided by pumps starting up automatically subsequent to unintended power interruptions.



CAUTION!

There should be a normal possibility of disconnecting the pump from the mains power supply to switch it off. Install an On/Off switch as an option.

- Connect the pump to the mains/power supply using the mains cable.

DosingPump.ir

9 Start up



WARNING!

Dangerous reactions are possible due to contact of feed chemical with water

The feed chemical can mix and react in the liquid end with water remaining after testing in the factory.

- Read the safety data sheet on the feed chemical.
- Blast the liquid end with compressed air.
- Flush the liquid end with a suitable medium through the suction connector.



WARNING!

Risk of fingers being crushed

- Only adjust the stroke length when the pump is switched off.
- Only operate the metering pump with the cover (1) closed and the safety screw tightly screwed in.



CAUTION!

Danger with dangerous feed chemicals

Contact with the feed chemical is possible provided the following handling instructions are adhered to.

- If the feed chemical is dangerous, take appropriate safety precautions when carrying out the following handling instructions.
- Adhere to the feed chemical safety data sheet.



CAUTION!

Warning of feed chemical spraying around

An unsuitable feed chemical can damage the parts of the pump that come into contact with the chemical.

- Take into account the resistance of the materials that come into contact with the medium when selecting the feed chemical - refer to the ProMinent® Resistance List in the Product Catalogue or at www.prominent.com.de/downloads.

DosingPump.ir



- *Reliable metering cannot be guaranteed after the metering pump has been idle for some time, as the feed chemical can crystallise in the valves and on the diaphragm. Regularly check the valves and diaphragm.*
- *The metering pump should prime at 100% stroke length, as the priming lift depends on the stroke volume when the liquid end is empty. If the metering pump has to prime at a smaller stroke length and is not priming, reduce the priming lift (i.e. briefly lift up the storage tank with the feed chemical).*

Starting up the metering pump

1. ➤ Fill the liquid end - ☞ 'Filling the liquid end' on page 26.
2. ➤ Check the pump connectors and connections for leak-tightness.
3. ➤ Check the suction valve and discharge valve for leak-tightness and tighten if necessary.
4. ➤ Check the liquid end for leak-tightness and tighten the screws on the dosing head if necessary - see below for starting torque.
5. ➤ Only with bleed valve: Check whether the bleed valve is closed.

Draining the liquid end

With feed chemicals that should not come into contact with water.

1. ➤ Turn the pump so that the pressure connector is facing downwards.
2. ➤ Allow water to flow out of the liquid end.
3. ➤ Flush the suction connector from above with a suitable medium or blast with compressed air.

DosingPump.ir

Filling the liquid end

With liquid ends without bleed valve:

1. ➤ Connect the suction line to the liquid end but not yet to the discharge line.
2. ➤ If fitted: Close the shut-off valve on the discharge side.
3. ➤ Connect a short, transparent section of hose to the discharge valve.
4. ➤ Remove the cover (1) and check whether the stroke length is set to 100%.
5. ➤ If not, set the stroke length to 100% - refer to "Adjusting stroke length".
6. ➤ Switch on the metering pump and allow to work at maximum stroke length and stroke rate until some feed chemical becomes visible in the short section of hose.
⇒ The liquid end has been filled completely without bubbles.
7. ➤ Switch off the metering pump.
8. ➤ Connect the discharge line to the liquid end.

Continue as described under "Concluding start up".

With liquid ends with bleed valve:

1. ➤ Connect the suction and discharge line to the liquid end.
2. ➤ Connect the return line.
3. ➤ Open the bleed valve by turning the star-shaped handle in a counter-clockwise direction.
⇒ You can now use the return line to bleed the pump.
4. ➤ Remove the cover (1) and check whether the stroke length is set to 100%.
5. ➤ If not, set the stroke length to 100% - refer to "Adjusting stroke length".
6. ➤ Switch on the metering pump and allow to work at maximum stroke length and stroke rate until some feed chemical becomes visible in the return or discharge line.
⇒ The liquid end has been filled completely without bubbles.
7. ➤ Switch off the metering pump.
8. ➤ Close the bleed valve.

Continue as described under "Concluding start up".

Concluding start up.





1. ➤ Start up the relief valve in the system in line with its operating instructions.
2. ➤ Start up the system.
3. ➤ After 24 hours of operation: Tighten the screws on the dosing head - see below for tightening torque.

DosingPump.ir

Tightening torque

Data	Value	Unit
Tightening torque for screws:	4.5 ... 5.0	Nm

Adjusting the stroke length

1.  Remove the cover (1).
2.  Replace the latched slide (9) onto the eccentric disc.
3.  Set the eccentric disc (10) to 100 %.
4.  Lock the latched slide in place.
5.  Replace the cover (1) and secure with the safety screw.

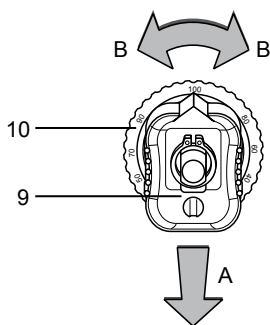

P_ALP_0008_SW

Fig. 6

DosingPump.ir

10 Maintenance



WARNING!

It is mandatory that you read the safety information and specifications in the "Storage, Transport and Unpacking" chapter prior to shipping the pump.



CAUTION!

Warning of feed chemical spraying around

Feed chemical can spray out of the hydraulic components if they are manipulated or opened due to pressure in the liquid end and adjacent parts of the system.

- Disconnect the pump from the mains power supply and ensure that it cannot be switched on again by unauthorised persons.
- Depressurise the system before commencing any work on hydraulic parts.

DosingPump.ir

Standard liquid ends:

Interval	Maintenance work	Personnel
Quarterly*	<ul style="list-style-type: none"> ■ Check the metering diaphragm for damage** - refer to "Repair". ■ Check that the hydraulic lines are fixed firmly to the liquid end. ■ Check that the suction valve and discharge valve are fitted tightly. ■ Check the tightness of the entire liquid end - particularly around the leakage hole - refer to ↻ 'Standard liquid ends:' on page 29! ■ Check that the flow is correct: Allow the pump to prime briefly - turn the multifunctional switch briefly to "Test" ■ Check that the electrical connections are intact. ■ Check the integrity of the housing. ■ Check that the dosing head screws are tight. 	Technical personnel

* Under normal loading (approx. 30 % of continuous operation)

Under heavy loading (e.g. continuous operation): Shorter intervals.

** Check the diaphragm frequently with feed chemicals that put particular pressure on the diaphragm, e.g. those containing abrasive additives.

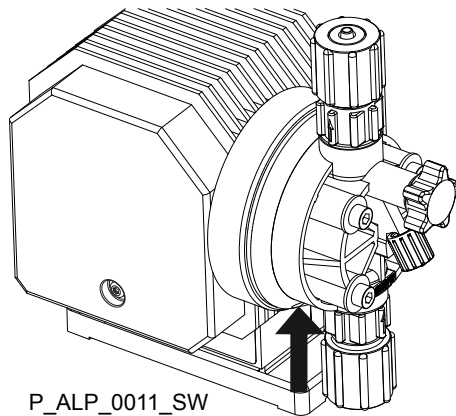

Fig. 7: Leakage hole

DosingPump.ir

Maintenance

Liquid ends with bleed valve:

Interval	Maintenance work	Personnel
Quarterly*	<p>In addition:</p> <ul style="list-style-type: none">■ Check that the bypass line is fixed firmly to the liquid end■ Check that the bleed valve is tight.■ Check the discharge and bypass line for kinks■ Check that the bleed valve is operating correctly.	Technical personnel

* Under normal loading (approx. 30 % of continuous operation)

Under heavy loading (e.g. continuous operation): Shorter intervals.

Tightening torque

Data	Value	Unit
Tightening torque for screws:	4.5 ... 5.0	Nm

DosingPump.ir

11 Repairs

Safety notes



WARNING!

Danger of an electric shock

Unauthorised repairs inside the pump can result in an electric shock.

For this reason repairs inside the pump should only be carried out by a ProMinent branch office or representative, in particular the following:

- Replacement of damaged mains connection lines
- Replacement of fuses



WARNING!

It is mandatory that you read the safety information and specifications in the "Storage, Transport and Unpacking" chapter prior to shipping the pump.



WARNING!

Contact with the feed chemical

Parts that come into contact with the feed chemical are exposed and touched during repair work.

- Protect yourself against the feed chemical in case it is hazardous. Read the safety data sheet on the feed chemical.



CAUTION!

Warning of feed chemical spraying around

Feed chemical can spray out of the hydraulic components if they are manipulated or opened due to pressure in the liquid end and adjacent parts of the system.

- Disconnect the pump from the mains power supply and ensure that it cannot be switched on again by unauthorised persons.
- Depressurise the system before commencing any work on hydraulic parts.

Repairs that may be carried out by qualified technical personnel, in accordance with the operating instructions:

- Cleaning valves
- Replacing the diaphragm

All other repairs: Contact the responsible ProMinent branch!

11.1 Cleaning valves

Personnel:

- Technical personnel



Warning of faulty operation

Refer to the exploded views on the CD when working on the unit.

DosingPump.ir

11.2 Replacing the diaphragm

- If necessary take protective measures.
- Adhere to the safety data sheet for the feed chemical.
- Ensure that the system is at atmospheric pressure.

- Disconnect the pump from the mains power supply.
- Empty the liquid end (turn the liquid end upside down and allow the feed chemical to run out; flush out with a suitable medium; flush the liquid end thoroughly when using hazardous feed chemicals!)

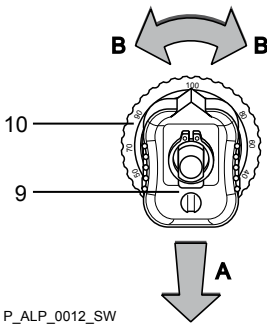

Fig. 8

- Set the eccentric disc (10) to "0".



The latched slide (9) cannot lock in this position.

⇒ The drive axle is then difficult to turn.

- Switch off the pump.
- Unscrew the hydraulic connectors on the discharge and suction side.
- With PP types with bleed valve: Firstly remove the bleed valve (grip), then lift off the cover of the liquid end with a screw driver.
- Remove the screws (6a).
- Fully remove the dosing head (6) from the motor mount (2).

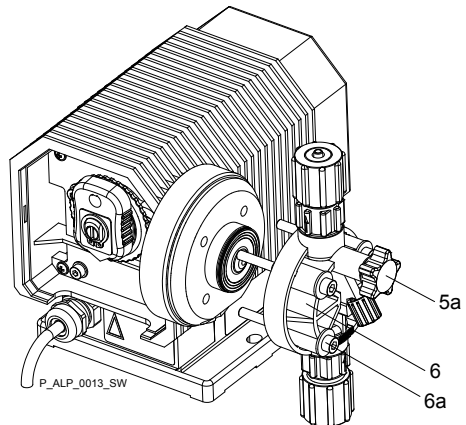
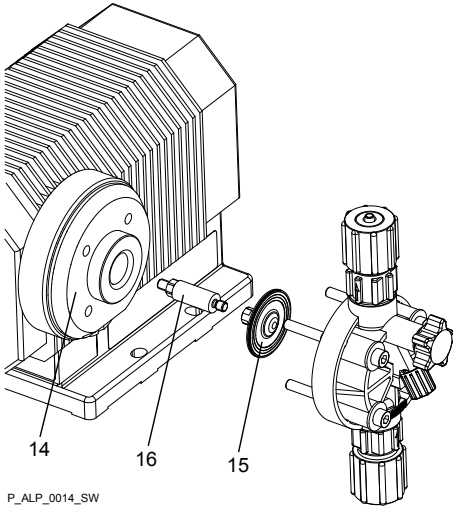

Fig. 9

DosingPump.ir

Pump types 1001, 1002, 1004, 1008, 0707, 0417: (Diaphragm WITHOUT holes, threaded rod without hexagonal nut)



P_ALP_0014_SW

Fig. 10

1. ➤ Loosen the diaphragm (15) by turning to the left - use pliers if necessary.
2. ➤ If the threaded rod (16) has come loose together with the diaphragm, unscrew the diaphragm from the threaded rod (turning to the left) - using pliers if necessary.
3. ➤ Screw the threaded rod into the connecting rod thread and use a flat wrench (SW9) to tighten securely at the width across flats.
4. ➤ Position the backplate (14) on the pump housing.
5. ➤ Screw the diaphragm onto the threaded rod and tighten manually. Ensure that the backplate no longer moves from side to side, although it should still be able to turn slightly.
6. ➤ Place the dosing head (2) with the screws (1) onto the diaphragm (3) and the backplate (4) - ensure that the suction connector points downwards in the pump's subsequent fitting position.
7. ➤ Gently tighten the screws (6a) and then tighten cross-wise.

DosingPump.ir

Pump type 0230: (Diaphragm WITH holes, threaded rod with hexagonal nut)

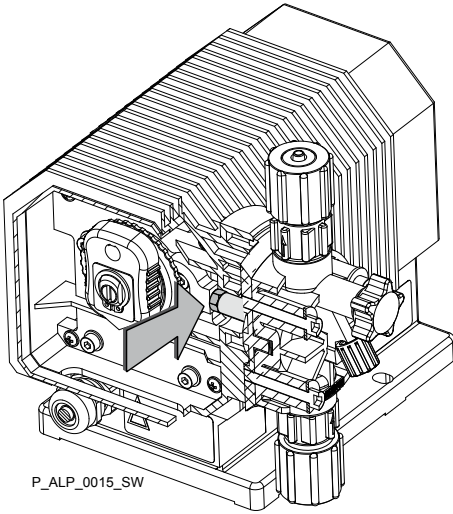

Fig. 11

1. ➔ Use a flat wrench (SW 8) to loosen the hexagonal nut (arrow) in front of the connecting rod by about one turn.
2. ➔ Loosen the diaphragm (15) with the backplate (14) and the threaded rod (16) from the motor mount (2) by turning it to the left.

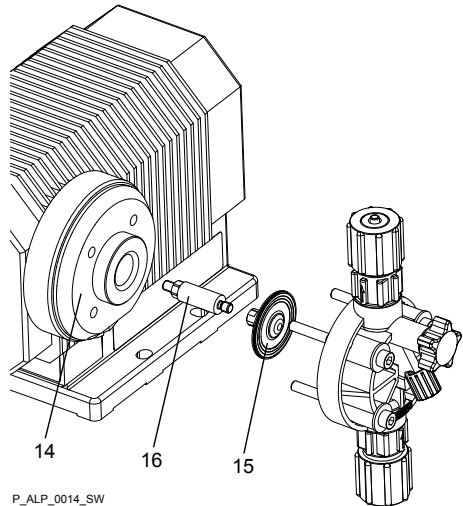

Fig. 12

3. ➔ Unscrew the threaded rod (16) from the diaphragm (15) (possibly holding the threaded rod with pliers and loosening the diaphragm by turning it to the left).
4. ➔ Insert the threaded rod (16) into a new diaphragm and, using pliers, screw it in until it is lying tightly against the diaphragm.

**CAUTION!**

There should be no gap visible between the diaphragm and the contact surface of the threaded rod.

5. ➤ Screw the hexagonal nut (17) onto the threaded rod (16) until it will go no further.
6. ➤ Insert the diaphragm with the threaded rod into the backplate (14) and screw the entire unit onto the connecting rod (18) until it will go no further. (The stroke length should still be 0 here.)
7. ➤ Turn the diaphragm back until the 4 holes in the diaphragm and backplate are precisely aligned.
8. ➤ Ensure that the suction connector is pointing downwards and then using the screws (6a) to place it onto the diaphragm and the backplate - the suction connector should be pointing downwards in the pump's subsequent fitting position.
9. ➤ Gently tighten the screws (6a) and then tighten cross-wise.

Concluding the work

1. ➤ With PP types with bleed valve: Allow the cover of the liquid end to rest in the dosing head, then press the grip on the bleed valve into the dosing head.
2. ➤ Turn the hexagonal nut (17) against the connecting rod (18) and gently tighten.
3. ➤ Set the stroke length required and lock the latched slide (9) into place.
4. ➤ Replace the cover (1) and secure with the safety screw.
5. ➤ Bleed the pump - refer to the "Start up" chapter.

**CAUTION!****Leakage possible**

- Check the tightening torque of the screws after 24 hours of operation!
- With PP and PV dosing heads, check the tightening torque again after three months!

DosingPump.ir

Tightening torque

Data	Value	Unit
Tightening torque for screws:	4.5 ... 5.0	Nm

11.3 Replacing the complete dosing head



- *The bleed valve is open on delivery.*
- *Re-tighten the bleed valve (5) after priming and bleeding.*
- *Check that the suction and discharge valves are tightened.*

12 Troubleshooting

Safety notes



WARNING!

Warning of dangerous or unknown feed chemical

Should a dangerous or unknown feed chemical be used: It may escape from the hydraulic components when working on the pump.

- Take appropriate protective measures before working on the pump (e.g. safety glasses, safety gloves, ...). Observe the safety data sheet for the feed chemical.
- Drain and flush the liquid end before working on the pump.



WARNING!

Risk of fingers being crushed

- Only adjust the stroke length when the pump is switched off.
- Only operate the metering pump with the cover (1) closed and the safety screw tightly screwed in.



CAUTION!

Warning of feed chemical spraying around

Feed chemical can spray out of the hydraulic components if they are manipulated or opened due to pressure in the liquid end and adjacent parts of the system.

- Disconnect the pump from the mains power supply and ensure that it cannot be switched on again by unauthorised persons.
- Depressurise the system before commencing any work on hydraulic parts.

DosingPump.ir

12.1 Faults and troubleshooting

Fault description	Cause	Remedy	Personnel
Pump does not prime in spite of full stroke motion and bleeding.	Minor crystalline deposits on the ball seat due to the valves drying out	Take suction hose out of the storage tank and thoroughly flush out the liquid end	Technical personnel
	Major crystalline deposits on the ball seat due to the valves drying out	Dismantle and clean the valves.	Technical personnel
Fluid is escaping from the backplate.	The screws in the dosing head are too loose	Tighten the screws in the dosing head crosswise - refer to "Repair" for tightening torque.	Instructed personnel
	The diaphragm is damaged.	Replace the diaphragm - refer to "Repair".	Technical personnel
The pump automatically switches off during metering.	The circuit breaker has switched off the overheated motor as the back pressure is too high.	<p>Disconnect the pump from the mains power supply.</p> <p>Check whether a shut-off device is closed or there is a blockage on the discharge side or reduce the back pressure.</p> <p>Re-connect the metering pump to the mains voltage. The circuit breaker switches the pump on again once the motor has cooled down.</p>	Instructed personnel
	The circuit breaker has switched off the motor due to the motor overheating, as the intake or drain openings for the motor cooling air are blocked.	<p>Disconnect the pump from the mains power supply.</p> <p>Examine and clean the intake and drain opening for the motor cooling air to the bottom of the pump.</p> <p>Re-connect the metering pump to the mains voltage. The circuit breaker switches the pump on again once the motor has cooled down.</p>	Technical personnel

DosingPump.ir

Fault description	Cause	Remedy	Personnel
The pump is not working despite being connected to the mains voltage.	The pending back pressure is greater than the permissible operating or starting pressure.	Check whether a shut-off device is closed or there is a blockage on the discharge side or reduce the back pressure.	Instructed personnel

12.2 All other faults

Please contact the responsible ProMinent branch or representative!

DosingPump.ir

13 Decommissioning and disposal

13.1 Decommissioning

Decommissioning

WARNING!

Danger from chemical residue

There is normally chemical residue in the liquid end and on the housing after operation. This chemical residue could be hazardous to people.

- It is mandatory that the safety information in the "Storage, transport and unpacking" chapter are read before shipping or transport.
- Thoroughly clean the liquid end and the housing of chemicals and dirt. Adhere to the material safety data sheet for the feed chemical.

WARNING!

Warning of hazardous feed chemical

Should a dangerous feed chemical be used: it may escape from the hydraulic components when working on the pump, material failure or incorrect handling of the pump.

- Take appropriate protective measures before working on the pump (e.g. safety glasses, safety gloves, ...). Adhere to the material safety data sheet for the feed chemical.
- Drain and flush the liquid end before working on the pump.

CAUTION!





Warning of feed chemical spraying around

Feed chemical can spray out of the hydraulic components if they are manipulated or opened due to pressure in the liquid end and adjacent parts of the system.

- Disconnect the pump from the mains power supply and ensure that it cannot be switched on again by unauthorised persons.
- Depressurise the system before commencing any work on hydraulic parts.

Danger of damage to the device

Take into account the information in the "Storage, transport and unpacking" chapter if the system is decommissioned for a temporary period.

-  **1.** Disconnect the pump from the mains/ power supply.
-  **2.** De-pressurise the discharge line.
-  **3.** Drain the liquid end by turning the pump upside down and allowing the feed chemical to run out.
-  **4.** Flush the liquid end with a suitable medium; flush the dosing head thoroughly when using hazardous feed chemicals!

DosingPump.ir

13.2 Disposal



CAUTION!

Environmental hazard due to incorrect disposal

There are components in the pump, which can have a toxic effect on the environment.

- Note the pertinent regulations currently applicable in your country!

In accordance with the European Directive 2012/19/EU on waste electrical and electronic equipment, this device features the symbol showing a waste bin with a line through it. The device must not be disposed of along with domestic waste. To return the device, use the return and collection systems available and observe the local legal requirements.

Sign indicating EU collection system



DosingPump.ir

14 Technical data

Performance data for alpha, version c

Type	Minimum pump capacity at maximum back pressure		Minimum pump capacity at medium back pressure		Stroke rate	Connector size outside Ø x inside Ø	Suction lift*	Priming lift**	Maximum permissible starting pressure	Max. permissible priming pressure on the suction side
	bar	l/h	bar	l/h						
50 Hz design										
1001	10	0.9	5.0	1.0	30	6x4	5.0	2.6	10	5.0
1002	10	1.8	5.0	2.1	58	6x4	5.0	3.6	10	5.0
1004	10	3.5	5.0	3.9	58	8x5	5.0	3.6	10	5.0
1008	10	7.7	5.0	8.6	128	8x5	5.0	3.6	10	5.0
0707	7	6.9	3.0	7.7	58	8x5	4.0	4.1	7	3.5
0417	4	17.0	2.0	18.3	128	8x5	4.0	4.1	4	2.0
0230	2	29.7	1.0	32.7	128	12x9	3.0	3.1	2	1.0
60 Hz design										
1001	10	1.1	5.0	1.3	36	6x4	5.0	2.6	10	5.0
1002	10	2.2	5.0	2.6	69	6x4	5.0	3.6	10	5.0
1004	10	4.1	5.0	4.7	69	8x5	5.0	3.6	10	5.0
1008	10	8.9	5.0	10.4	154	8x5	5.0	3.6	7	5.0
0707	7	8.3	3.0	9.2	69	8x5	4.0	4.1	7	3.5
0417	4	20.6	2.0	21.9	154	8x5	4.0	4.1	2.5	2.0
0230	2	34.4	1.0	39.2	154	12x9	3.0	3.1	1.5	1.0

*) Suction lift with unfilled dosing head, valves wetted.

Pump capacity was calculated using water and a metering pump warmed to operating temperature.



With types 1001, 1002 and 1004, the pump capacity can fall to zero at 20% stroke length and back pressure of > 4 bar.

Precision

Data	Value	Unit
Capacity range of the product range	-10 ... +10	% *
Reproducibility	±2	% **

* - with max. stroke length and max. operating pressure for all material versions

** - with constant conditions, minimum back pressure of 1 bar, min. 40 % stroke length, water as the feed chemical and over short time intervals (5 min)

Viscosity

The liquid ends are suitable for the following viscosity ranges:

Design	Range	Unit
Standard	0 ... 200	mPas
With valve springs	200 ... 500	mPas

DosingPump.ir

Technical data

Material specifications

Design	Dosing head	Suction/pressure connector	Seals	Valve balls
PPE	Polypropylene	Polypropylene	EPDM	Ceramic
PPB	Polypropylene	Polypropylene	FPM-B	Ceramic
NPE	Clear acrylic	PVC	EPDM	Ceramic
NPB	Clear acrylic	PVC	FPM-B	Ceramic
PVT	PVDF	PVDF	PTFE	Ceramic

Diaphragm with a PTFE coating.

FPM = fluorine rubber.

Electrical data

Tab. 1: El. connector "A", "B", "C", 230 VAC (220 ... 240V)

	50 Hz	60 Hz
Capacity	50 W	45 W
Power consumption	0.4 A	0.35 A

Tab. 2: Elec. connector "D" 115 VAC (108 ... 134V)

	50 Hz	60 Hz
Capacity	60 W	50 W
Power consumption	0.9 A	1.1 A

Circuit breaker

The drive motor is fitted with a circuit breaker, which automatically switches off the motor when it overheats to more than 106 °C; the circuit breaker switches the pump on again once the motor has cooled down.

DosingPump.ir

Pump temperature, compl.

Data	Value	Unit
Storage and transport temperature	-20 ... +60	°C
Ambient temperature in operation (drive and control):	-10 ... +45	°C

Liquid end temperature, long-term*

Data	Value	Unit
Liquid end temperature	-10 ... +35	°C

* long term at max. operating pressure, dependent on the ambient temperature and the feed chemical temperature

Degree of protection

Protection against accidental contact and humidity:

IP 23 according to DIN EN 0470 Part 1

with horizontal pump foot with an upright pump

Sound pressure level

Sound pressure level LpA < 70 dB according to EN ISO 20361

at maximum stroke length, maximum stroke rate, maximum back pressure (water)

Shipping weight

Shipping weight	3 kg
-----------------	------

DosingPump.ir

15 Design Documents



Design documents, such as dimensional drawings, ordering data (exploded drawings), performance diagrams ... are available in the relevant online version of these operating instructions on our website.

When searching on the website, please use simply the 6-digit order number for these operating instructions - this can be found at the bottom left corner of the cover page. You can find an older version – if the website provides the print number – using the print number (say "BA G 059 04/15 EN" – which can be found at the bottom right of the cover page).

DosingPump.ir

16 Dimensional drawings

Dimensional drawing of alpha ALPc

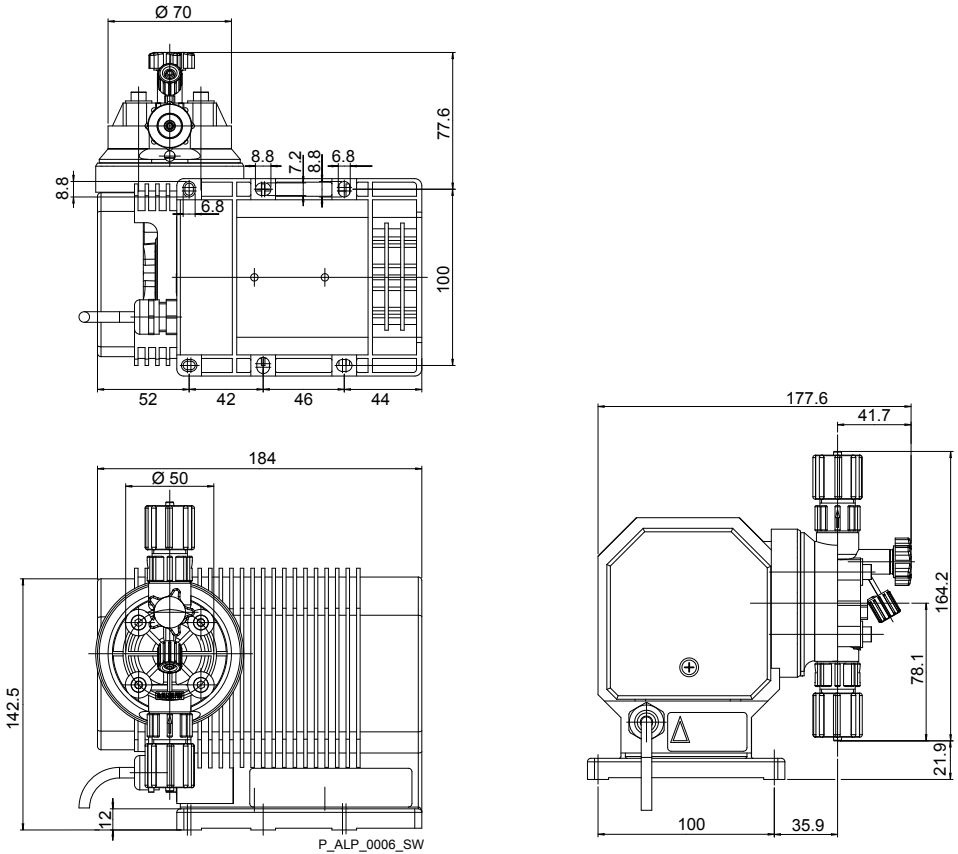

Fig. 13: Dimension drawing of ALPc - dimensions in mm

DosingPump.ir

Further order information

17 Further order information

Spare parts kits for alpha c

Type	PPE	PPB	NPE	NPB	PVT
1001, 1002, 1004, 1008	1001647	1001655	1001716	1001724	1023110
0707, 0417	1001649	1001657	1001718	1001726	1023112
0230	1001650	1001658	1001719	1001727	1023113

Replacement diaphragms for alpha c

Type	Part no.
1001, 1002, 1004, 1008	1000247
0707, 0417	1000249
0230	1000250

Further sources of information

Further information on spare parts, accessories and options can be found in:

- the identity code
- the ProMinent® Product Catalogue
- at www.prominent.com

DosingPump.ir

18 Declaration of Conformity for Machinery

In accordance with DIRECTIVE 2006/42/EC OF THE EUROPEAN PARLIAMENT AND OF THE COUNCIL, Appendix I, BASIC HEALTH AND SAFETY REQUIREMENTS, section 1.7.4.2. C.

We,

- ProMinent GmbH
- Im Schuhmachergewann 5 - 11
- DE - 69123 Heidelberg,

hereby declare that the product specified in the following, complies with the relevant basic health and safety requirements of the EC Directive, on the basis of its functional concept and design and in the version distributed by us.

Any modification to the product not approved by us will invalidate this declaration.

Tab. 3: Extract from the Declaration of Conformity

Designation of the product:	Metering pump, alpha product range
Product type:	ALPc ...
Serial number:	see nameplate on the device
Relevant EC directives:	Machinery Directive (2006/42/EC) Compliance with the protection targets of the Low Voltage Directive according to Appendix I, No. 1.5.1 of the Machinery Directive (2006/42/EC) EMC Directive (2014/30/EU)
Harmonised standards applied, in particular:	EN ISO 12100:2010 EN 809:1998 + A1:2009 + AC:2010 EN 61010-1:2010 EN 61000-6-2:2005 + AC:2005 EN 61000-6-3:2007 + A1:2011 + AC:2012
Date:	20/04/2016

You can download the Declaration of Conformity at www.prominent.com.

DosingPump.ir

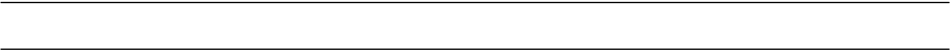

DosingPump.ir

DosingPump.ir



ProMinent GmbH
Im Schuhmachergewann 5-11
69123 Heidelberg
Germany
Telephone: +49 6221 842-0
Fax: +49 6221 842-419
Email: info@prominent.com
Internet: www.prominent.com

986353, 3, en_GB

© 2013

DosingPump.ir