



**Membrane Electromagnetic
Dosing Pumps
PROXIMA PSP164
with inbuilt Conductivity meter**



TECHNICAL MANUAL
(v.1120)



DosingPump.ir

STEIEL Elettronica S.r.l. – Viale Europa, 24 – 35020 Ponte San Nicolò – PADOVA ITALIA
Tel. +39-049-8961488 – www.steiel.it – info@steiel.it

Certified Company, according to UNI EN ISO 9001 standards

How to ship the pump

To send back the pump for repairing or calibration purposes, proceed as follows:

- Fill the module “REPAIR REQUEST AND DECONTAMINATION DECLARATION” supplied with this manual and include it in the transport documentation.
- Clean the pump properly, to eliminate any hazardous residuals.

The manufacturer can modify the instrument or the technical manual without advanced notice.

Warranty

All STEIEL products are warranted for a period of 12 months from the delivery date.

Warranty is not valid if all instructions of installation, maintenance, and use, are not strictly followed by the user.

Local regulations and applicable standards have also to be followed.

In particular, the warranties regarding the operational safety and reliability of dosing pumps will be recognized only if the following conditions are fulfilled:

- The installation, wiring, adjustment, maintenance and repairs performed only by qualified personnel
- The dosing pump was used according to instructions provided in this manual
- Only original spare parts have been used for repairs

TABLE OF CONTENTS

HEALTH AND SAFETY	4
PACKING LIST	6
INTRODUCTION AND PRINCIPLE OF OPERATION.....	6
TECHNICAL DATA	7
INSTALLATION.....	9
HYDRAULIC CONNECTIONS	10
ELECTRICAL CONNECTIONS.....	11
DESCRIPTION OF THE FRONT PANEL	15
START-UP	16
DISPLAY VISUALIZATIONS	16
AUTOSET	17
CONFIGURATION.....	18
<i>List of Parameters</i>	19
<i>Meaning of Parameters</i>	20
SET TIME (DATE / TIME ADJUSTMENT).....	26
MANUAL OPERATION.....	26
CALIBRATION OF THE ANALOGIC INPUT.....	27
CALIBRATION OF THE INJECTION VOLUME.....	28
ERRORS AND ALARMS	29
SERIAL LINE (optional)	30
ADDITIONAL VISUALIZATIONS.....	33
“SERVICE” MENU	34
MAINTENANCE.....	35
EXPLODED VIEW OF DOSING HEADS.....	39
ACCESSORIES AND SPARE PARTS.....	41
CODING SYSTEM.....	42

HEALTH AND SAFETY



The pump must be operated **ONLY** by authorized and trained technical personnel. All instructions and prescriptions in the technical manual must be strictly followed. **Failure to follow these instructions can result in serious damages to the equipment and, in extreme cases, to people.**

Warnings



This manual is dedicated to the technical personnel responsible of the installation, management, and maintenance of the plants. The manufacturer assumes no responsibility for damages or malfunctions occurring after intervention by non-authorized personnel, or not compliant with the prescribed instructions.



All maintenance or repair must be performed with the system isolated both electrically and hydraulically. Before performing any operation on the pump, unplug the pump and discharge the liquid from the pump head and tubes.

Never operate on working pump!



During maintenance and repair of parts that normally become in contact with chemicals, always wear all prescribed personal protections (gloves, clothes, glasses, etc.).

Any intervention must be performed ONLY by qualified personnel and using original spare parts.



Dispose of waste material and consumables accordingly with local regulations.

Intended Use

The pump can only be used after correct and proper installation and start-up, accordingly with the technical data and specifications listed in this instruction manual.

Observe the general restrictions on the viscosity ranges and chemical resistance of the materials in contact with the dosed product.

The pump must only be used for liquid dosing.

All other uses are prohibited and any possible modifications.

The pump is not suitable for dosing gaseous or solid media.

The pump is not suitable for dosing combustible substances without appropriate protective measures, it is not designed for dosing explosive liquids and is not intended for use in hazardous area.

The pump is not intended for use outdoors without appropriate protective measures.

Safety



The pump can start to dose as soon as it is powered. It is recommended to install an emergency switch in the power line or connect the pump to the emergency stop system of the installation.

DosingPump.ir



Risk of electric shock! If the pump housing is damaged, immediately unplug the pump and power it again only after a proper repair by an authorized technician.



Attention to dosed chemicals! Before any operation on the pump, discharge the liquid from the pump head and pipes. Take all necessary personal protective measures (i.e. gloves and goggles), as indicated in the SDS of the chemical, which must be always available and updated.



Attention to splashes! To prevent any leakage of the dosing liquid while operating on the pump, for example during maintenance, before the intervention depressurize all hydraulic components of the system.

It is advisable to install a discharge valve in the delivery line upstream of the pump, to prevent overpressure or explosion of hydraulic components due to a block on the injection line.



Install the pump in an easily accessible place and respect the prescribed maintenance schedule.



The pump must be always switched on (powered)! Operations are activated / stopped by using the EXT.CON/PULSE input, in order to protect the electronics.

In Case of Emergency

In an emergency, unplug the pump or disconnect the power through the emergency stop switch, depending on the installation.

In case of leakage of the dosed liquid, depressurize the hydraulic system and take the protective measures indicated in the SDS of the chemical.

Technical Service

The technical service is provided only by qualified technicians, trained, and authorized by the manufacturer for installation, maintenance and repair of the pump.

PACKING LIST

- 1) Dosing pump
- 2) Pack of PVDF ring nuts, fittings and gaskets for suction and delivery valves
- 3) Standard accessories for pump: PVC Crystal hose for suction line (2 m, diameter depending on pump flow rate), PVC Crystal hose for bleed line (2 m, 4x6 mm), semi-rigid PE hose for injection line (5 m, diameter depending on pump flow rate), foot filter and injection valve
- 4) Cable with M8 female connector (corresponding in number to the options provided)
- 5) Technical manual

INTRODUCTION AND PRINCIPLE OF OPERATION

The PROXIMA PSP is a series of professional electromagnetic pumps with mechanical adjustment of stroke and housing designed for horizontal mounting.

The membrane is actuated by an electromagnet controlled by an electric signal. When the membrane is pushed towards the dosing head, a pressure is generated that closes the suction valve and makes the liquid flow from the head through the delivery valve. When the membrane moves away from the head, the negative pressure in the head closes the delivery valve and the liquid to be dosed flows through the suction valve.

To facilitate the pump priming, the standard head is equipped with a manual vent valve. Alternative heads are also available: head with self-purge and special head for dosage of highly viscous liquids. The dosage yield is determined by the stroke length and dosing frequency. The stroke adjustment knob allows to set the stroke length from 0 to 100%.

Moreover, these pumps are equipped with advanced digital electronics and a configuration menu, which allow their full and customized management.

The PSP164 model, with inbuilt conductivity meter, is equipped with an input for two-electrode conductivity cell, also with integrated NTC sensor for thermo-compensation of readings.

Different options are available for measurement range and cell constant (see “Technical Data” section); note that these characteristics cannot be modified by the customer and, therefore, must necessarily be specified on order.

In addition, the pump can be configured to control a blow-down valve of cooling towers, through the optional relay output.

Main Characteristics

- Multi-voltage power supply
- Multi-language interface
- Separated inputs for level control and injection flow control
- Alarms and errors (diagnostic) directly shown on display
- Two configuration levels, standard and advanced, both protected by password
- Configuration and calibration data saving on non-volatile memory for at least 10 years
- Internal clock, powered by buffer battery that ensures proper functioning even in case of power failure; can be used for scheduling the pump operations
- Optional input for injection flow control
- One optional output, selectable among the following options: NO/NC configurable relay, “Repetition” output for remotely sending the magnet pulse to other pumps equipped with pulse input, or an RS485 port with Modbus RTU protocol
- Built-in counter of injected litres, useful for maintenance requests and resettable through password
- Counters of membrane working hours and shots, displayable and resettable through “service” password
- Factory data restoring with different codes for different pump configurations
- Self-priming function
- Mechanical adjustment of stroke (flow rate)

DosingPump.ir

TECHNICAL DATA

Power Supply	100 ... 240 V~, 50/60 Hz, 60 VA max. (standard version: cable with Schuko plug; without plug upon request)
Electrical Protection	Fuse 5x20 F1.6A
Display	2-row (x 12 characters) alphanumeric LCD, with backlight
Keys	5 membrane-keys (CAL, ESC, ↑, ↓, ON-OFF)
LED	2 LEDs: "POWER" and "PULSE"
Clock	RTC, accuracy ±5 sec/month, with CR2032 buffer battery (life of at least 3 years with no power supply)
Dosage Precision	-5 ... +10% (with max stroke length)
Materials	Housing PP reinforced with glass fibre Head PVDF (even with self-bleeding valve), PP or methacrylate Membrane high quality EPDM with fabric reinforcement, steel core and PTFE coating on the side in contact with the fluid Seals PTFE for PVDF heads, FPM or EPDM for PP or methacrylate heads Valves ceramic ball (with PVDF, PP or PVC body, depending on model)
Viscosity of Dosed Product	0 ... 200 mPas (standard head) 200 ... 500 mPas (head with spring valves) 500 ... 3000 mPas (PKT/HV special head, only for flow rates 0510, 0516, 0807, 1304, 1307, 2002, 2004)
Environment	Storage temperature -20 ... +60 °C Working Temperature -10 ... +45 °C RH max 92 % no condensing
Protection Rate	IP65
Dimensions	110 x 260 x h 190 mm (maximum overall dimensions, wirings excluded)
Weight	approx. 3 to 5.5 kg (depending on model)

Note: Dimensions and weight may slightly differ depending on configurations.

Conductivity Input

available measurement ranges, depending on cell constant:

K = 10 cm → 2, 20, 200 µS/cm

K = 1 cm → 20, 200, 2000 µS/cm, 20 mS/cm

K = 0.1 cm → 200, 2000 µS/cm, 20, 200 mS/cm

K = 5 cm → 2, 20, 200, 2000 µS/cm

These data cannot be modified and must be specified upon order!

Precision > 0.5% FS, repeatability > 0.3% FS

(Note: The precision and repeatability data refer to the electronics only and do not consider the sensor)

Automatic thermo-compensation through the inbuilt NTC10K sensor,
with a fixed coefficient of 2%/°C within the 0...50°C range; error max ±3%.

If the thermo-compensation is not required, please specify it upon order!

DosingPump.ir

Digital Inputs

General Technical Data	<ul style="list-style-type: none">• vacuum voltage: typical 10 V, max 18 V• current with contact closed: max 3.8 mA• power supply voltage for micro-magnetic: 18 V \pm5%, max 10 mA• frequency: max 10 Hz (minimum pulse duration 50 msec)
EXT.CON.S.	consent input, configurable as NO/NC; accept voltage-free contact, for example from the filtration pump contactor or 3-wire micro-magnetic sensor (flow sensor of the water to the cell)
LEV	voltage-free contact, from level sensor
FLW	optional; contact from sensor of the injection flow control

Outputs (optional)

Alarm relay	NO / NC contact, configurable, max. 30V~ (40V-), 3A resistive
Pulse Repetition	SSR (solid state relay) contact, max 40V, 50mA; duration 60msec
Serial Port	RS485, three-wire, opto-isolated, 9600 or 19200 or 38400 BPS, 8 bits, no parity, 1 stop bit, with Modbus RTU communication protocol

Hydraulic Specifications

Note: These data refer to pumps with standard head, 100% stroke, frequency 180 strokes/min, ambient temperature 25°C, dosing water with a delivery hose of 5 meters.

Standard heads can dose liquids with a maximum viscosity of 200 mPa•s (cP), with a yield decrease depending on pressure losses.

For self-bleeding heads, consider a decrease of the dosage yield of about 25%.

Version	Flow rate max (l/h)	Pressure max (bar)	Hose (IDxOD) **
0216	2	16	4x6
0416 (*)	4	16	4x6
0425 (*)	4	25	4x6
0510	5	10	4x6 (5x8)
0516	5	16	4x6 (5x8)
0807	8	7	5x8
0810	8	10	5x8
1304	13	4	5x8
1307	13	7	5x8
2002	20	2	9x12
2004	20	4	9x12
3202	32	2	9x12

() Versions available upon request.*

*(**) When dosing liquids of medium viscosity (valves with spring), for models 0510 and 0516 it is recommended to use hoses with a diameter bigger than the standard one; the value is shown within brackets.*

Warning! The PKT/HV head to dose highly viscous liquids needs a hose 16x24 mm.

DosingPump.ir

INSTALLATION



Warning! Failure to follow instructions can cause damage to the equipment and, in extreme cases, to people.

Warning! When working on the pump wear the adequate systems of personal protection (gloves, apron, goggles).

- Install the pump **away from sources of heat, humidity and chemical fumes**. Also prevent that the pump is exposed to direct sunlight to avoid overheating. The minimum temperature shall be such as to ensure the solution to be dosed remains in a fluid state.
- It is recommended to install the pump above the level of the liquid to be dosed, to a maximum height of 1.5 meters from the bottom of the tank. If the pump is installed below the level of the liquid, it is advisable to install a multifunctional valve.
- If the pump is placed above the tank and the reagent fumes could be especially aggressive, check the tank seals.
- The PROXIMA PSP pumps are designed for horizontal installation, but a special bracket (optional) for wall mounting is also available.
- The delivery connection is always on top of the dosing head and the hose connected goes to the system to be treated (use the white semi-rigid PE hose). The suction connection instead is always positioned in the lower part of the head (use for the suction line the soft transparent PVC Crystal tube) and insert the foot filter in the bottom of the container of liquid to be dosed. The pump head is also equipped with a manual vent valve, to which is connected a soft transparent PVC Crystal tube, for the return to the tank.

Note: If the product to be dosed is concentrated sulfuric acid, previously remove any water from the pump head and use a polyethylene suction hose.

- To avoid damage of the hydraulic connections, all operations to tighten the pipe on the dosing pump must be performed by hand, without using any tool.
- If the pump does not switch on even if powered, check the fuse F1 (the fuse position is indicated in the section “Electrical Connection – Electronic Boards”). The fuse replacement must be performed only by a qualified technician and using a fuse of the same size and dimension.
- As general rule, the sensor connection cables should be as short as possible and kept far from power cables.
- Do not power the pump in parallel with high inductive loads (e.g. circulation pumps), because at shutdown the inductive load causes an overvoltage which damages the power circuit and the power supply of the pump.
- **The pump must be always switched on (powered)!** Operations are activated / stopped by using the EXT.CON/PULSE input, in order to protect the electronics.
- The pump is equipped with **mechanical adjustment of stroke**. To prevent damages to this mechanism, the stroke must be decreased with the pump in operation (during dosage), while the stroke increase (clockwise rotation) is always feasible.

HYDRAULIC CONNECTIONS

Suction and Delivery Lines

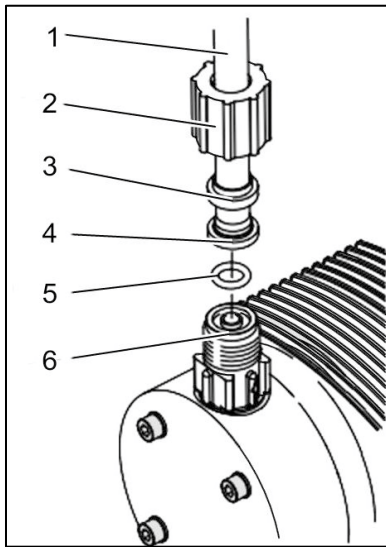

1. Hose
2. Threaded ring
3. Locking ring
4. Pipe-holder nozzle
5. Gasket
6. Valve

- Cut the hose to be connected to the pump (PVC Crystal for suction line or PE for delivery line).
- Insert the threaded ring (2) and the locking ring (3) on the tube.
- Attach the tube to the nozzle (4) pushing it up to the stop.
- Put the hose with the nozzle on the valve (6) and tighten the threaded ring while pushing the tube. Check that the gasket (5) is correctly located.
- Tighten by lightly pulling the tube and locking the threaded ring.

Notes:

- Gaskets (5) are supplied of different materials: FPM (black, with green mark on the edge), EPDM (black) and PTFE (white). Choose the material most suitable to your application. It is advisable to favour the FPM and EPDM gaskets for their greater elasticity, and use PTFE gaskets only in case of chemical compatibility / resistance problems.
- It is recommended not to reuse the PTFE gaskets, because they deform permanently when compressed and therefore cannot ensure the sealing.
- Check that the delivery hose is correctly installed, verifying that it is not damaged by rubbing against rigid bodies.
- Avoid unnecessary bends and hose choking on both suction and delivery lines.

Vent (or purge) Line

- Use the 4x6 PVC Crystal hose. Fix the return hose on the purge valve of the dosing head.
- Put the free end of the return pipe into the tank of product to be dosed.
- Cut the pipe so that it cannot dive in the feed chemical.

DosingPump.ir

ELECTRICAL CONNECTIONS

The pump is supplied with prewired power cable and connectors for the available inputs / outputs, depending on the desired configuration.

Below is an indicative diagram of the arrangement of the connectors and pin-out of the M8 axial connector, used for pump wiring.

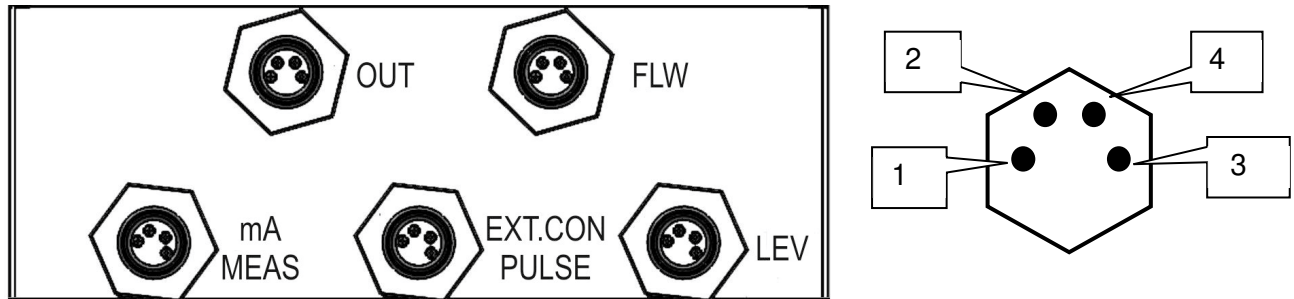

Power Cable

This cable (standard length 1.5 m) comes out from the right side of the pump and must be connected to the mains, in accordance with relevant regulations. The standard version is equipped with Schuko plug. In case of power cable without plug, please note that it is a three-wire cable (brown=phase, blue=neutral, yellow/green=earth); Exchanging phase and neutral connections does not affect the proper functioning of the pump, but the internal protection fuse will be connected to the neutral instead of the phase; The power supply grounding (yellow/green wire) must be connected to the grounding of the electrical system, in accordance with applicable requirements.

LEV Connector – Level Control Input

The pump is preconfigured for disabling the dosage in case of low level of liquid in the tank. The level control is made through a specific float sensor, supplied upon request. When the product level in the tank falls below the level sensor, the pump stops dosing, the POWER LED blinks and the “Level!” message is displayed.

This contact can be configured as NO (factory setting) or NC.

You can connect a voltage-free contact [pins 3 and 4] or an NPN micro-magnetic [connect the brown wire (positive) to pin 2, the black wire (output) to pin 3 and the blue wire (negative) to pin 4].

EXT.CON / PULSE Connector – Consent Input

This input can be configured as NO or NC, and can be wired to a voltage-free contact [pin 3 and 4] or to an NPN micro-magnetic sensor [connect the brown wire (power supply positive) to pin 2, the black wire (output) to pin 3 and the blue wire (negative) to pin 4].

mA / MEAS Connector – Conductivity Signal Input

This input is available on M8 connector, to be wired as follows: connect the cell electrodes to pins 1 and 4, the NTC10K sensor wires to pins 2 and 3, and the cable shield to pin 2.

FLW Connector – Input for Injection Flow Control (optional)

Optional input, available on axial M8 connector, for the control of injected liquid, not to be confused with the control of water flow to the sensor. It allows monitoring the actual injection (passage of liquid) at each magnet pulse.

The flow sensor is generally supplied tested and complete with cable and connector, to be installed on the delivery valve. The signal comes from the NPN micro-magnetic sensor through pins 2 (brown wire), 3 (black wire) and 4 (blue wire).

OUT Connector – Relay or Pulse repetition (optional)

This optional output is available on axial connector, at pins 1 and 2.

In case of relay, no polarity should be respected, but the output must be suitably protected in function of the load (suppressors, RC, etc.). The relay output may be configured at the factory for working as alarm or pulse repetition (to be specified upon order).

OUT Connector – Serial Port (optional)

The optional serial output is available on axial connector, with the following pin-out:

- RS485: pin1 = B, pin2 = A, pin3 = GND.

NOTE: *The pump is provided with just one plug for connecting an optional output, to be chosen among relay (standard or SSR for pulse repetition) or serial port (RS485)*



NOTE: *For wirings on M8 connector, a 4-wire cable is supplied / available, with prewired female connector, and the following pin-out:*

pin1= brown wire; pin2 = white; pin3 = blue; pin4 = black.

Warning! *If, by mistake, the brown wire (pin1) and the black wire (pin4) are short-circuited, the power supply turns off and could be damaged!*

ELECTRONIC BOARDS (for technical personnel only)

The information given in this section is **intended for skilled technicians, authorized** for maintenance and / or repair of dosing pumps. Prior to open the pump, it is recommended to place the stroke knob at a known position (e.g. 50%), so that you can restore the same condition when closing the pump, in order to not lose the factory mechanical calibration.

View of the front / input board

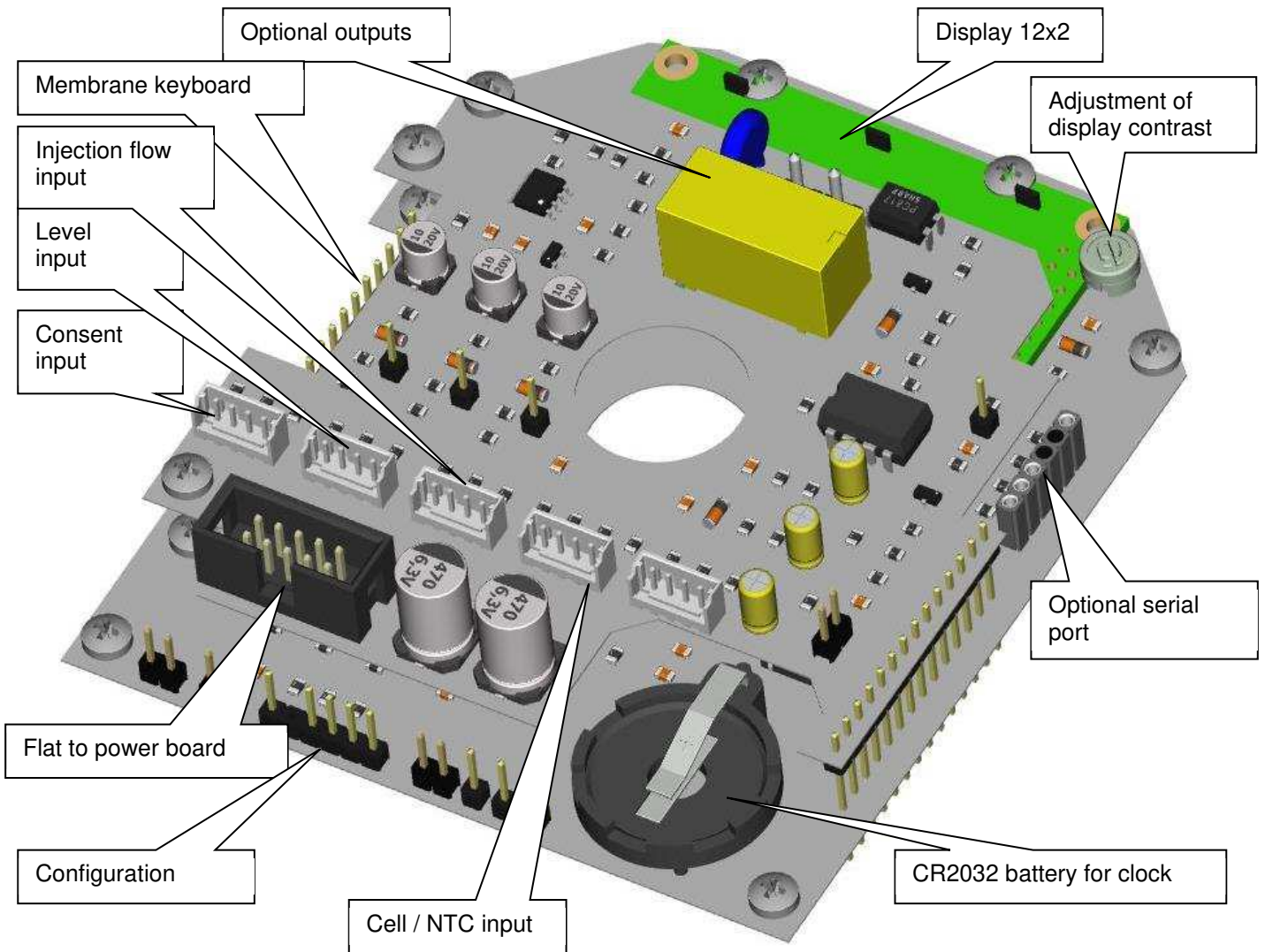

Allowed operations:

- **Replacement of the buffer battery:** if the clock cannot keep time and date after a pump shutdown, the old battery can be replaced with a new one (CR2032 type). Pay attention to the polarity because an incorrect installation may damage the battery and the clock. This operation does not require to remove the board from its housing.
- **Adjustment of the display contrast:** this adjustment is performed at the factory as the pump is fully calibrated. However, it may be necessary to adjust the contrast when the display is ageing or if the pump operates in a quite cold (< 8°C) or hot (>35°C) environment.

DosingPump.ir

View of the power board

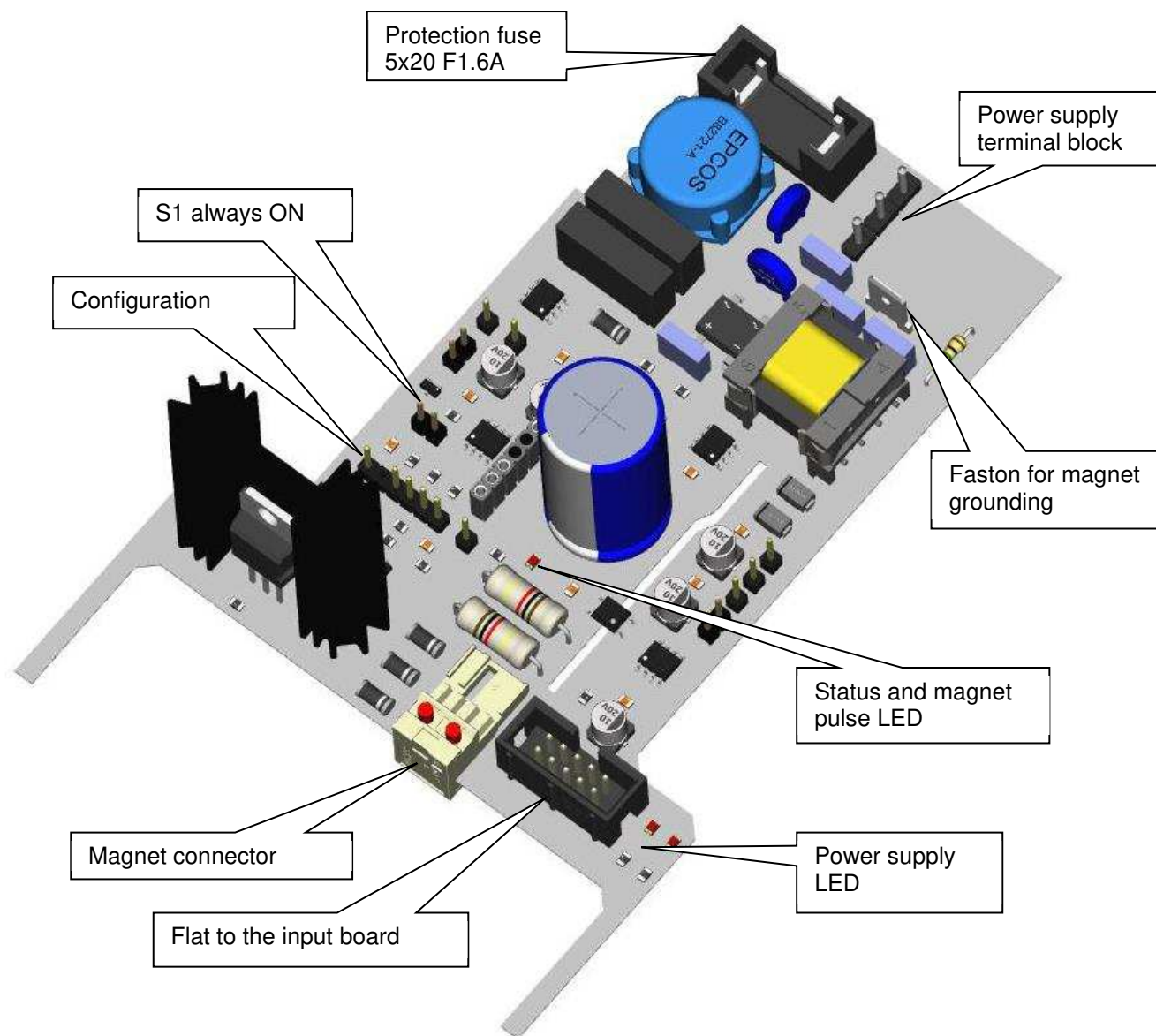

Allowed operations:

- **Fuse replacement** on the power line: use a fuse of the same size and dimensions. Before replacing the fuse, verify the blowing cause (for example, overvoltage, wrong connection, atmospheric discharge); if burn marks are noticed on the board near the power supply terminal block, replace the board.
- **Board replacement:** the board should be replaced if clear signs of burning are noticed or if the two power LED do not light up (with powered board and fuse ok).
- If the status LED blinks fast, check that the S1 jumper is in ON position. If the problem persists, the board needs to be replaced or reprogrammed.
- When replacing the magnet or board, check the correct connection of the magnet and grounding faston.

DESCRIPTION OF THE FRONT PANEL



ON/OFF Key Enables / disables the magnet without shutting down the pump

MENU/OK Key Allows the access to a circular menu, in which the options may be scrolled using the arrow keys $\uparrow\downarrow$; in menu modes, confirms the modification and/or the entered value. Circular menu:

- **Autoset**
- **Standard Configuration**
- **Advanced Configuration**
- **Set Time**
- **Manual (for example, for priming)**
- **Calibration of analogic input**
- **Injection Calibration**
- **Additional Visualizations**
- **Service**

A	d	d	i	t	.	V	i	s	u	a	l
O	K		C	o	n	f	i	r	m		

For further details, please refer to the related paragraphs. Depending on pump model and configuration, some options are not available (for example, a pump configured for steady operation will not list the calibration of analogic input). Confirm the access to desired menu by pressing the MENU/OK key. If no menu is confirmed, after approximately 1 minute, the pump resumes to normal operation / display.

ESC Key Allows to quit the calibration and configuration modes without saving any modification; in normal operation mode, activates the additional visualizations (read only) on the display bottom line, showing the following info sequence:

- **Threshold**
- **Sensor Offset**
- **Sensor Gain**
- **Current Time**
- **SW Version (software)**
- **Mechanical Stroke**
- **Current Working Frequency**
- **Current Flow Rate**

			1	5	0		u	S			
P	S	P	1	6	4		0	6	.	2	1

- **Litre-Counter (for service / maintenance request)**
- **Error of injection flow control**
- **Status of the output relay**
- **Pump internal temperature**

These are the same info provided in the “Additional Visualizations” menu, but in short form. For further details, please refer to the relevant section.

About one minute after the last pressure of the ESC key, the pump returns to the display set through configuration parameter.

↑ **Key** In calibration, configuration, or manual modes, increases the displayed value.
 ↓ **Key** In calibration, configuration, or manual modes, decreases the displayed value.

Notes:

- Pressing simultaneously the ↑ / ↓ keys, will force manual operation of the pump at the maximum dosing frequency.
- Pressing simultaneously the ↑ / ↓ / MENU/OK keys, will activate the pump priming. Press ON/OFF to stop this operation.

POWER LED Slow flashing light → indicates smooth operation of the pump
 Fast flashing light → indicates an alarm / error / fault
 Two blinks and one pause → indicate operation in progress (data editing, calibration, or manual mode)

PULSE LED Flashes at each pulse of the magnet

DISPLAY 2-row (x 12 characters) alphanumeric LCD with backlight; shows all information in the selected language

START-UP

At start-up the pump displays for three seconds the firmware version and configuration, then checks the status of data stored and shows the detected errors (for details about possible error messages, see the "Errors and Alarms" section). After this initial phase, the pump starts working in the programmed mode.

DISPLAY VISUALIZATIONS

During normal operation, the display shows the pump status, according to the setting of parameter P12 (see “Configuration” section).

		5	0	.	0	0		u	S		
T	u	e		1	0	:	4	5	:	3	7

A typical display is shown in the figure.

Any active error or malfunctioning is displayed on the bottom line. If several errors are active, the related messages are shown cyclically, about one every two seconds.

AUTOSET

This function allows to load / restore the factory settings related to the selected configuration.

Enter the "Autoset" menu and select the desired configuration by scrolling the various available options with the arrow keys \uparrow \downarrow , then press the MENU/OK to confirm the function activation.

Note: If a password has been set for the standard configuration menu (P39), it will be also requested for accessing this function.

	A	u	t	o	s	e	t				
	O	K		C	o	n	f	i	r	m	

	A	u	t	o	s	e	t				
	C	o	n	d	.	2	0	0	u	S	

This action resets all the offset and gain values of measurements and should be activated only in case of malfunctioning due to a wrong setting, or if a total reboot of the pump is needed before installing it in a new plant.

Note: Upon order of significant production batches, different values for specific restaurations can be agreed with the customer; contact the manufacturer for details.

WARNING! After restoring factory settings, check the values of flow rate, stroke length and maintenance volumes; if necessary, reconfigure them manually and/or perform required calibrations.

WARNING! Any special option of your pump will be not considered and, therefore, must be reconfigured manually.

Summary of specific recovery values for different configurations of the **PSP164 v.0621** pump

	Autoset	Steady	2 μ S	20 μ S	200 μ S	2000 μ S	20 mS	200 mS
P10	Threshold	---	1.000 μ S	10.00 μ S	100.0 μ S	1000 μ S	10.00mS	100.0mS
P11	Hysteresis	---	0.100 μ S	1.00 μ S	10.0 μ S	100 μ S	1.00 mS	10.0 mS
P12	Display Type	2	4	4	4	4	4	4
P37	Start Delay	00:02	00:20	00:20	00:20	00:20	00:20	00:20

The parameters not listed in the previous tables have common values for all configurations, and are summarized here below:

P02	Relay Output	NC		P25	2° Turn ON	---
P03	Level Input	NO		P26	2° Turn OFF	---
P04	Consent Input	NO		P27	3° Turn ON	---
P05	Manual Frequency	90 i/m		P28	3° Turn OFF	---
P06	Max Frequency	40 i/m		P29	4° Turn ON	---
P07	Min Frequency	0		P30	4° Turn OFF	---
P08	Adjustment type	ON-OFF		P31	5° Turn ON	---
P09	Adjustment direction	Upwards		P32	5° Turn OFF	---
P13	Injection Flow Control	Excluded		P33	6° Turn ON	---
P14	Injection Flow Error	---		P34	6° Turn OFF	---
P15	Priming Pulses	100		P35	7° Turn ON	---
P16	Injection Volume	#1		P36	7° Turn OFF	---
P17	Mechanical Stroke	#1		P38	ON at start-up	Remember
P18	Max litres	0 L		P39	Language	#1
P19	Reset litres	No		P40	PSW standard	0
P20	Max dosing time	0:00		P41	PSW advanced	0
P21	Reset max dosing time	No		P42	Serial Line Type	9600
P22	Clock	Excluded		P43	Serial Address	0
P23	1° Turn ON	---		P44	Options	0
P24	1° Turn OFF	---				

#1 : Parameters P16, P17 and P39 are not affected by the restoring action, but keep in memory the values previously set.

CONFIGURATION

The PROXIMA PSP pumps feature two configuration levels: **standard** and **advanced**.

The standard configuration is normally accessed by the end user, for editing a few parameters, as the adjustment thresholds, dosing frequency and display language.

The advanced configuration instead allows to change all parameters and is normally protected by a password to prevent incorrect settings by unauthorized personnel.

The procedure is however the same for both configurations.

- 1) Press the MENU/OK key to access the menu list; use the arrow keys $\uparrow\downarrow$ to select the desired configuration mode and press MENU/OK to confirm.
- 2) If the configuration is protected by password, use the arrow keys $\uparrow\downarrow$ to enter the value, then press MENU/OK to confirm.
- 3) The display shows the first available parameter, depending on the selected configuration mode (advanced or standard).
- 4) A cursor appears under the parameter number, for indicating that you can scroll the list of editable parameters by using the arrow keys $\uparrow\downarrow$.
- 5) Pressing the MENU/OK key, the cursor moves under the parameter value, which can be, therefore, modified by using the arrow keys $\uparrow\downarrow$.
- 6) Press MENU/OK to confirm the new value or press ESC to exit without saving the modification.
- 7) Using this sequence, you can display and edit all (available) parameters.

	S	t	.	C	o	n	f	i	g	.
O	K			C	o	n	f	i	r	m

	A	d	v	.	C	o	n	f	i	g
O	K			C	o	n	f	i	r	m

	A	d	v	.	C	o	n	f	i	g	
P	a	s	s	w	o	r	d	:	0	0	0

	P	u	m	p		T	y	p	e	
P	0	1				2	0	0	u	S

Notes:

- As soon as the access to a configuration menu is confirmed, the magnet is automatically disabled. As a result, when you exit the configuration mode, the "Manual Stop" message is displayed. To restart the normal operation, press the ON-OFF key.
- If no key is pressed for about one minute, the pump automatically quits the configuration mode.
- The settable values are limited by the processor. Anyway, it is recommended to always check the consistency between the application and the set value.
- When exiting the configuration mode, the access level returns to zero.
- All menus are "circular": when you scroll with the arrow keys and reach the maximum, then the minimum is shown and vice versa.
- The parameter value can be a number to be set (for example, intervention threshold) or an option to be selected (e.g. NO / NC).

List of Parameters

In this section you can find the full list of configuration parameters, divided per pump version.

The parameter P01 sets the operation mode and determines the parameters P04, P06...P11, while all the remaining parameters are common for all models.

It is recommended to fill the last column with the values set for your specific application.



Warning! The full list of parameters can be accessed only in the “Advanced Configuration” menu, while the “Standard Configuration” allows editing only the parameters highlighted in bold in the below tables.

PAR.	DESCRIPTION	MIN VALUE	MAX VALUE	FACTORY SETTING	SET VALUE
P01	Pump Type	Steady, 2 µS/cm, 20 µS/cm, 200 µS/cm, 2000 µS/cm, 20 mS/cm, 200 mS/cm		200 µS/cm	
P02	Relay Output	NO / NC / Repetition / Timer / Threshold / mA		NO	
P03	Level Input	NO / NC		NO	
P04	Consent Input	NO / NC		NO	
P05	Manual Frequency (injections/minute)	0 i/m	180 i/m	90 i/m	
P06	Max Frequency (injections/minute)	2 i/m	180 i/m	40 i/m	
P07	Min Frequency (injections/minute)	0 i/m	90 i/m	0 i/m	
P08	Adjustment Type	ON-OFF / Proportional		Proport.	
P09	Adjustment Direction	Upwards / Downwards		Upwards	
P10	Threshold (desired value)	0.0 µS	200.0 µS	100.0 µS	
P11	Hysteresis (non-intervention or proportional band)	0.5 µS	20.0 µS	100.0 µS	
P12	Display Type	0	10	2	
P13	Control of the injection flow input	Excluded / Active / Self-priming		Excluded	
P14	Dosage Error	2 %	50 %	20 %	
P15	Priming Pulses	5	500	100	
P16	Injection Volume	0.05 ml	9.99 ml	1.11 ml	
P17	Mechanical Stroke Position	5 %	100 %	100 %	
P18	Technical Service Request	0 L	9999 L	0 L	
P19	Litre-Counter Reset	Yes / No		No	
P20	Max dosing time (hours : minutes)	0:00	8:00	0:00	
P21	Reset max dosing time alarm	Yes / No		No	
P22	Clock	Excluded / Daily / Weekly		Excluded	
P23 ... P36	Turn ON / Turn OFF Times	0:00	23:59	0:00	
P37	Start delay (minutes : seconds)	00:02	59:59	00:02	
P38	ON at start-up	Remember last status / Always (ON) / Never (ON)		Remember	
P39	Language	ITA / ENG / FRA / ESP / DEU		ITA	
P40	Password for Standard Configuration	0	999	0	
P41	Password for Advanced Configuration	0	999	0	

PAR.	DESCRIPTION	MIN VALUE	MAX VALUE	FACTORY SETTING	SET VALUE
P42	Serial Line Type (BPS) (A=Ascii; MB = Modbus)	A 9600, A 9200, A 38400, MB 9600, MB 9200, MB 38400		A 9600	
P43	Serial Address	0	126	0	
P44	Options	0	3	0	

Meaning of Parameters

PARAMETER 01 PUMP TYPE

The following operation modes are available:

- **Steady** = the pump (if enabled) works at the constant frequency set in P05
- **Conductivity range** = the pump is equipped with an input for two-electrode conductivity cell; this parameter is related to the configuration of the internal preamplifier and must be specify upon order. **Do not modify the factory setting!**
Available ranges: 2 µS/cm, 20 µS/cm, 200 µS/cm, 2000 µS/cm, 20 mS/cm, 200 mS/cm.



Warning! When changing the setting of this parameter, to avoid any malfunction, it is essential to check all the parameters related to the operating mode. If in doubt, use the AUTASET function for restoring the specific factory setting.

PARAMETER 02 RELAY OUTPUT

The output may be configured in several ways, listed here below:

- **NO** = contact is Normally Open, and closes upon errors or malfunctioning
- **NC** = contact is Normally Closed, and opens upon errors or malfunctioning
- **Repetition** = the pulse supplied to the magnet is transmitted to the output and the repeated signal can drive a second pump provided with pulse input, which will then operate synchronously
- **Timer** = the contact closes according to the times and mode configured in the parameter P21 (Timer); this configuration allows to choose an operation schedule for other devices not provided with an internal clock (for example, an additional pump)
- **Threshold** (this option is available only for pumps with analogic input) = the contact closes for triggering the required dosage according to the measurement and threshold value set in P10; even in this case, the contact can control an additional synchronized device

Important Notes:

- *The relay output is an option; check if it is provided.*
- **Warning!** *To set this output as "Repetition", a special relay is needed, which must be requested upon order. In fact, an SSR is used, suitably dimensioned to perform the numerous pulse switches without deteriorates.*
- *Any option provided (see P44), can "win" on this parameter.*

PARAMETER 03 LEVEL INPUT

The level input can be set as NO (Normally Open when level is detected) or NC (Normally Closed) contact. **Standard level contacts are NO type.**

In installations where high security is required, it is advisable to set the NC contact to have a signal even when the sensor is disconnected, or the cable is cut (fail safe).

The level alarm is generated with a certain delay, to avoid pump turning ON / OFF due to liquid fluctuation.

PARAMETER 04 EXTERNAL CONSENT / FLOW INPUT

If the pump operates in steady mode or in case of model with analogic input, this contact input can be set as NO (Normally Open when enabled) or NC (Normally Closed for activating the pump).

The standard factory configuration is NO contact. If the input is connected to a flow sensor which closes the consent contact in the presence of water flow, this input must be configured as NC.

The consent / flow alarm is generated with a certain delay, to avoid pump turning ON / OFF due to flow rate fluctuations in the probe-holder.

PARAMETER 05 MANUAL FREQUENCY

If the pumps operate in steady mode, this parameter is used to set the working frequency. Moreover, for all operation modes, if manual operation is forced, the pumps start working at this frequency, which can be then modified using the arrow keys.

PARAMETER 06 MAX FREQUENCY

This parameter sets the maximum working frequency of the pump automatic operations.

This limit can cause an accumulation of pulses in the case of pump controlled by a pulse emitting water meter, or a lower dosage in case of pump working in batch mode.

PARAMETER 07 MIN FREQUENCY

This parameter allows to set a minimum dosage frequency, for triggering dosage even if it is not requested, in order to ensure for example a minimum and constant basic chlorination.

If this function is not needed, set the parameter to zero.

PARAMETER 08 ADJUSTMENT TYPE

This parameter allows to set the adjustment type to be used for achieving the desired threshold.

- ON-OFF Control: the pump works at constant rate (set in parameter P06) until the threshold (parameter P10) is reached and stops when this limit is exceeded; when measurement moves away from the threshold value \pm hysteresis (parameter P11), the pump resumes dosing.
- Proportional Control: the dosing frequency (pulses/minute) varies from the minimum value (threshold reached) set in P07 up to the maximum set in the parameter P06 (when measurement is far from the threshold more than the proportional band set in P11). The dosing frequency is automatically calculated by the microcontroller. This type of adjustment allows to reach the desired threshold more gradually than the ON-OFF operation.

PARAMETER 09 ADJUSTMENT DIRECTION

This parameter allows the user to choose the dosing direction, upwards or downwards.

For simplicity, the chlorination / dichlorination directions are defined.

PARAMETER 10 THRESHOLD

This parameter allows to set the desired measurement value to be reached. When this limit is exceeded, the pump stops dosing.

PARAMETER 11 HYSTERESIS (non-intervention or proportional band)

The setting of this parameter depends on the adjustment type (parameter P08):

- In case of ON-OFF control, this is the dosage “no intervention” window, typically set quite narrow, in the range of 10 ... 30 points.
- In case of proportional control, this is the adjustment band, typically set between 30 and 50 points. To avoid error messages and malfunctioning, the microcontroller checks that the difference between the minimum and max frequency is greater than 2 pulses/minute, and that the proportional band is greater than 20 points. If these conditions are not fulfilled, minimum values are forced.

PARAMETER 12 DISPLAY TYPE

This parameter allows to choose the information to be displayed during normal operations. The available options depend on pump configuration, as shown in the following tables.

Pump in STEADY mode		
P12	Display row 1	Display row 2
0	Frequency [pulses/min]	"Constant" // Litre-counter
1	Flow rate [L/h]	"Constant" // Litre-counter
2	Frequency [pulses/min]	"Constant" // Date, Time
3	Flow rate [L/h]	"Constant" // Date, Time
4	Frequency [pulses/min]	"Constant" // Flow rate
5	Flow rate [L/h]	"Constant" // Frequency
6	Frequency [pulses/min]	Litre-counter
7	Flow rate [L/h]	Litre-counter
8	Frequency [pulses/min]	Date, Time
9	Flow rate [L/h]	Date, Time
10	Frequency [pulses/min]	Flow rate [L/h]

Pump with ANALOGIC INPUT		
P12	Display row 1	Display row 2
0	Measurement	Frequency // Litre-counter
1	Measurement	Flow rate // Litre-counter
2	Measurement	Date, Time // Litre-counter
3	Measurement	Frequency // Flow rate
4	Measurement	Frequency // Threshold
5	Measurement	Flow rate // Threshold
6	Measurement	Frequency
7	Measurement	Flow rate
8	Measurement	Date, Time
9	Measurement	Litre-counter
10	Measurement	Threshold

Notes:

- Quotations are exactly the text displayed.
- The symbol // indicates that messages are shown alternatively on the display row.
- Measurement is always displayed with its measure unit, and changes depending on model and configuration.
- If measurement is out of the allowed range, the message "UR" (Under Range) or "OR" (Over Range) is displayed.
- Any error message will always appear on the second row, alternating with the expected information.

PARAMETER 13 CONTROL OF THE INJECTION FLOW INPUT

The pump may be equipped with an input for monitoring the actual passage of the liquid to be dosed on the injection hose, through a special accessory which must be installed directly on the delivery valve or tube. If the accessory is not mounted, exclude this feature.

This accessory consists of a small float, pushed down by gravity and by a spring, and housed in a casing of special geometry.

When the magnet sends a pulse, the amount of liquid to be dosed will flow violently into the housing and cause the float to rise. Once the pulse is completed, the float returns to the bottom, on its rest position. This movement is recorded by a special sensor (micro inductive NPN) that transmits it to the proper pump input (FLW). If the injection does not take place, for example for the presence of air in the pump head or clogging of the injection valve, even this movement does not occur.

The microcontroller compares the FLW input signal with the pulses sent by the magnet and stops the dosage if the number of injections is lower than the magnet shots, also considering the expected error percentage (that can be set in the next parameter).

This accessory can be used as a simple control or even for the **self-priming**. In this case, the microcontroller, after detecting the flow lack alarm, tries to automatically restart the pump, by executing the maximum number of injections set in P15. If at least 5 injections are correctly performed, the alarm deactivates and the pump resumes to normal operation. If instead the 100 injections are attempted

DosingPump.ir

unsuccessfully, the alarm remains active and, therefore, a user intervention is required to evaluate and solve the problem.



Warning! *The self-priming function is potentially hazardous! For example, in case of breakage or simply disconnection of the flow control while the pump works perfectly, the volume of 100 injections will be dosed in the system in less than one minute. Only a skilled technician can decide if using or not this function.*

PARAMETER 14 DOSAGE ERROR

This parameter allows to set the maximum percentage error allowed for the injection flow alarm. Typical values go from 10 to 20%, which can be decreased in case of installations where a high accuracy is required, or increased if dosing a liquid which can develop gas.

Note: *If the pump loses priming due to lack of liquid to be dosed, many pulses may be required to reactivate correct operations, normally many more than those allowed as error. In this case it is recommended to enter in manual mode (see “Manual Operation” section), correctly perform priming and then restore the normal operating conditions of the pump.*

PARAMETER 15 PRIMING PULSES

This parameter allows to set the maximum number of injections allowed when the pump tries an automatic priming, due to a lack of injection flow control signal.

Even if the priming is manually activated by pressing the MENU/OK / ↑ / ↓ keys simultaneously, the pump performs the maximum number of injections set in this parameter.

PARAMETER 16 INJECTION VOLUME

The injection volume is a specific characteristic of each pump and depends on the flow rate curve, mechanical stroke, counter-pressure, and viscosity of liquid to be injected. For the PROXIMA PSP pumps this volume can be derived from the flow rate curves or can be measured.

In this parameter is manually entered the volume in ml, derived from the flow rate (L/h) at the maximum injection frequency, using the formula $ml = l/h * 0.093$, or calculated by the microcontroller through the “Calibration of injection volume” function (see related section for details).

It is recommended to use this second calculation option, because the first one gives a theoretical result that does not consider the installation factors (counter-pressure, flow resistance, etc.).

This value is then used for calculating the instantaneous flow rate, for the litre-counter totalization, and for the operation calculations in “batch” mode.

PARAMETER 17 STROKE POSITION

Enter in this parameter the position of the mechanical stroke adjustment knob. To avoid errors, this parameter must be correctly set before performing calibration. If after the injection volume calibration this parameter is changed, automatically the processor calculates the new value of P16 and, therefore, all data of totalization and flow rate.

PARAMETER 18 TECHNICAL SERVICE REQUEST (MAX INJECTABLE LITRES)

A correct maintenance of the pump must be performed! You may decide to do it after a pump malfunctioning (error / fault / alarm) or set an operating limit. This parameter allows to enter a limit, in terms of injected litres. The value to be set depends on the installation characteristics and aggressiveness of dosed product. Generic applications suggest performing maintenance every 300...500 litres of injected product. When the litre-counter overcomes the value set in this parameter, the “Tech. Service” message is displayed. This kind of indication does not stop pump operations, but it is only a warning. If this function is not required, set P18=0.

PARAMETER 19 RESET LITRES

If P18 is not set to zero (P18 ≠ 0), after performing maintenance, the technician must reset the litre-counter by entering the value “12” in this parameter.

PARAMETER 20 MAX DOSING TIME

This parameter allows to enable a dosing time control (in hours : minutes), useful for pumps with analogic input / built-in meter.

When measurement deviates from the set threshold and the pump starts dosing, simultaneously starts this counter. If measurement returns to the threshold before the set time has elapsed, the adjustment

has been successfully completed. If, instead, the threshold is not reached within the set time, the pump stops dosing and displays the error message “**Max dosing**”.

This condition may be caused, for example, by an under-sizing of the pump with respect to the system needs, by the dosage of a too diluted product, by empty injections due to loss of priming, etc.

Enter zero means not using this function, while the upper limit is 8 hours.

PARAMETER 21 RESET MAX DOSING TIME ALARM

This parameter is linked to the previous one and allows to set the cancel mode of the alarm condition with consequent restore of normal operations / dosage.

By selecting the “Yes” option, the alarm is automatically reset as soon as measurement returns to the threshold value and the pump restores normal operating mode.

If, instead, you want the operations are restored only by the user intervention, select “No”. In this case, press the ON-OFF key twice to cancel the alarm.

Note: *This alarm also cancels by switching off and on the pump, or by entering the configuration mode.*

PARAMETER 22 CLOCK

This parameter may be set for 3 different working modes:

0 = clock disabled

1 = daily schedule (max 7 power ups and 7 power offs per day)

2 = weekly schedule (1 power up and 1 power off per day for the seven days of the week)

Note: *in case of weekly schedule, the day 1 corresponds to Monday, day 2 to Tuesday, day 3 to Wednesday, and so on.*

PARAMETERS P23...P36 1°TURN ON, 1°TURN OFF, 2°TURN ON, 2°TURN OFF, ...

Thanks to the internal clock, these parameters allow to set the hours of pump power up and power off. Setting one of these parameters to zero, means disabling it.

During the scheduled shutdown, the display shows the “Timer off” message.

Pay attention to enter the hours in ascending order, to avoid incorrect power ups / offs.

PARAMETER 37 START DELAY

Some measurement sensors at start-up need a certain stabilization (or polarization) time, during which readings are not reliable. This parameter allows to set an appropriate start-up delay (min. : seconds).

Be aware that a pH electrode needs just one minute, while the stabilization of a redox electrode may require up to 30 minutes. Sometimes this waiting time is also useful to compensate hydraulic delays at system start-up. Then set a time that activates when the pump is powered on, during which the injection is deactivated, and the display shows the countdown of this waiting time. Once this time has elapsed, the pump starts normal operations.

In case of pumps configured for steady or pulse mode, set P37=0.

PARAMETER 38 ON AT START-UP

At shutdown, the microcontroller stores the status of the ON-OFF key. At next power up, you can choose if restoring the status at shutdown or starting the pump always (or never) enabled.

PARAMETER 39 LANGUAGE

This parameter allows to set the interface language.

The available options are: Italian, English, French, Spanish and German.

PARAMETER 40 PASSWORD FOR STANDARD CONFIGURATION

This parameter allows to lock the standard configuration menu of the pump. Set a value different from zero to avoid unauthorized personnel accessing the configuration menu. In this case, when you try to access the standard configuration mode, the pump will ask for this password. Only by entering the value set in this parameter, you will be allowed to proceed. No password is set at the factory.

Note: *This password (if set) is also requested for accessing the manual mode and Autoset function.*

Warning! *If password is forgotten, the configuration menu cannot be accessed, and the pump must be sent to the manufacturer for unlocking it.*

PARAMETER 41 PASSWORD FOR ADVANCED CONFIGURATION

Same meaning and use of parameter P40 but referred to the advanced configuration.

PARAMETER 42 SERIAL LINE TYPE

If the pump is provided with the “serial output” option, this parameter (and the next one) allows to set the operating mode and rate of the serial line. You can choose between Ascii communication (no protocol) and Modbus RTU protocol.

Available communication rates are 9600, 19200 and 38400 BPS (bit per second).

The other transmission features are fixed: 8 bits, no parity, a stop bit.

Warning! *If the serial line is used to connect the pump to an RW14 system, this parameter must be set to Ascii 9600.*

PARAMETER 43 SERIAL ADDRESS

If the pump provided with serial port is connected to a Modbus network, you need to associate the slave address to which the master supervisor will refer. The available options range from 1 to 126. In case of Ascii communication, this parameter is not used.

PARAMETER 44 OPTIONS

This parameter is used to set the automatic blow-down of cooling towers. Configure **P44=1**.

Activating this function also requires the configuration of time schedule (daily or weekly, see P21...P35) for the biocide injection, while parameters P08...P11 are linked to the relay output which should drive the purge solenoid valve. Note that, while the pump is dosing on a timed schedule, even if measurement exceeds the set threshold, the relay output (purge solenoid valve) is not activated, for not losing the injected biocide.

If you need a pump, which controls the cooling tower purge system, please proceed as follows:

- Choose conductivity range and cell constant according to your system needs (e.g. 20 mS/cm, K=1 cm)
 - Order a PSP164 pump with the needed conductivity range, and a CCK1 conductivity cell with graphite electrodes and built-in NTC
 - First installation, recommended procedure:
 - o The dosing rate of the biocide (P06) is set at 180 i/m; if necessary, adjust this value.
 - o The conductivity threshold (P10), above which the purge valve is activated, is automatically set to 10.00 mS/cm, while the hysteresis (P11) is set to 0.10 mS/cm; if necessary, adjust these values.
 - o The timed dosage schedule (P22) is activated and set for daily operation.
 - o Two turn-on and turn-off times are automatically configured: P23=07:30, P24=07:35, P25=19:00 and P26=19:05. Adjust these settings according to your system needs (see parameters P23...P36).
 - o The automatic blow-down function is already enabled (P44=1).
 - o Reboot the pump to make all the settings effective.
 - Now the pump will operate as follows:
 - o Every day, from 7:30 to 7:35 and from 19:00 to 19:05, the pump injects the biocide. During these time intervals, the purge valve will be deactivated even if the set threshold was exceeded, and the purge valve was working, i.e., the injection time schedule has priority over the set intervention threshold. In all other times, if measurement exceeds the threshold, the output activates and, therefore, water is discharged from the tower. This will result in a reintegration with water at lower conductivity, such as to stop the solenoid valve just below the threshold limit (minus the hysteresis).
 - o After a biocide injection, even if the conductivity is above the set threshold, the relay output (solenoid valve) does not activate for 10 minutes (fixed time), to prevent discharging the biocide just injected.
-
- *Some parameters (e.g., output type, minimum frequency, adjustment type or direction) are not considered if this function is enabled.*
 - *If this function is entered, but no injection time is set, a configuration error is generated.*
 - *Any other functions of the pump or system must be correctly configured (e.g., optional input injection flow control).*
 - *Parameters of unused times must be set to zero.*



SET TIME (DATE / TIME ADJUSTMENT)

To adjust the time and day of the week, access the circular menu by pressing the MENU/OK key, scroll the available options with the arrow keys and select the “Set time” item; press again the MENU/OK key to confirm.

The display shows the current day and time. Use the ↓↑ arrow keys to adjust the values and press MENU/OK to confirm.

The adjustment sequence is day, hour, minutes, seconds. After confirming the seconds, the display automatically exits this menu.

To quit the procedure at any time, press ESC.

Access this feature for legal / solar time change or after replacing the buffer battery.

S	e	t		t	i	m	e				
O	K		C	o	n	f	i	r	m		

S	e	t		t	i	m	e				
W	e	d		1	6	:	5	4	:	3	2

MANUAL OPERATION

In order to manually operate the pump, access the circular menu by pressing the MENU/OK key, scroll the available options with the arrow keys and select the “Manual” item; press again the MENU/OK key to confirm.

Note: If a password has been set for the standard configuration menu (P39), it will be also requested for accessing this mode.

	M	a	n	u	a	l					
O	K		C	o	n	f	i	r	m		

	M	a	n	u	a	l					
M	a	n	u	a	l		S	t	o	p	

The display shows the rate set in parameter P05 and the message “Manual stop”.

Press the ON/OFF key to deactivate the pump. Pressing again the ON/OFF key will disable the pump. To quit this mode at any time, press ESC.

This function bypasses all alarms, and it is available even for pumps configured for steady operation mode; it allows the pump working even without consent or priming without generating an alarm for lack of injection flow.

Note: The manual operation may also be forced by pressing simultaneously the ↓↑ arrow keys. In this case the pump injects at the maximum set frequency.

CALIBRATION OF THE CONDUCTIVITY INPUT

Note that the ZERO (offset) error is normally very low (dry cell in air) and that the GAIN error is generally within $\pm 10\%$ (max mechanical tolerance of the cell). It is recommended not to calibrate if these values are not too far from the theoretical ones.

Before starting the calibration procedure, make sure you have a reference solution with a conductivity value of approximately 60...80 % of the pump full scale.

- 1) Keep the cell in air, completely dry.
- 2) Press MENU/OK to display the message "Calibration OK – Confirm".
- 3) Press MENU/OK again to confirm and display the message "↓ Offset – ↑ Gain".
- 4) Press the ↓ key to select the OFFSET calibration and the pump will show the zero value.
- 5) Press MENU/OK to confirm the ZERO point.
- 6) Immerse the cell in the calibration solution, checking that the electrodes are completely immersed and the liquid volume around the electrodes is consistent with the cell type; wait for temperature to stabilize.
- 7) Press MENU/OK to display the message "Calibration OK – Confirm".
- 8) Press MENU/OK again to confirm and display the message "↓ Offset – ↑ Gain".
- 9) Press the ↑ key to select the GAIN calibration and the pump will show the measured value.
- 10) Use the ↓↑ arrow keys to adjust the displayed value to that of the calibration solution.
- 11) Press MENU/OK to confirm.
- 12) Press ON/OFF to resume to normal operations.

If you try to perform a calibration at values too far from the factory settings, the pump will display the "Calibration failed!" error message and will discard the calibration. If so, check:

- a) that all the initial requirements were met*
- b) the quality of the calibration solution*

If no standard calibration solution is available, you can also use a liquid with a conductivity value of approximately 60...80 % of the pump full scale and an accurate and calibrated portable instrument as a reference for the reading. This instrument must feature a thermo-compensation coefficient of $2\%/^{\circ}\text{C}$ and be equipped with cell with inbuilt temperature sensor.

After performing a GAIN calibration, a small deviation of the reading from the correct value may be observed, due to an inaccurate determination of the linearity error of the conductivity meter. This deviation is more evident in the case of low conductivity ranges.

CALIBRATION OF THE INJECTION VOLUME

To get correct visualizations and calculation of flow rate and litre-counters, you need to correctly set the volume corresponding to a pump injection.

Access the circular menu by pressing the MENU/OK key, scroll the available options with the arrow keys and select the "Injection Calibration" item; press again MENU/OK to activate the procedure.

Perform calibration at the working conditions, checking that the following indications are fulfilled:

- Have a beaker of correct volume (at least 200 ml for low flow rates, 500 ml for high flow rates).
- The pump must be properly primed.
- The mechanical stroke adjustment knob must be in the same position which will be used for normal operation, and the corresponding parameter (P16) must be set accordingly.
- The pump delivery / injection line must be at the working pressure of the system.
- Temperatures should be at the average working level.
- It is generally advisable to calibrate with water; however, if the liquid to be injected is more viscous, calibrate using the dosing liquid.

Calibration procedure:

a) Immerse the suction lance (or suction hose only) in the beaker, filled till the maximum level with water (recommended) or with the dosing liquid.

b) Manually operate the pump to bring the level at a known value in the beaker (e.g. 200 ml).

c) Access the circular menu by pressing the MENU/OK key, scroll the available options with the arrow keys and select the "Injection Calibration" item; press again MENU/OK to confirm.

I	n	j	e	c	t	.	C	a	l	i	b
O	K		C	o	n	f	i	r	m		

d) Now the display asks to press the ON/OFF key to start calibration.

S	t	a	r	t	-	>	O	n	O	f	f
			0	Π		1	8	0	i	/	m

e) At this point (but even during calibration), the injection rate may be modified with the ↓↑ arrow keys.

f) Once started, the pump works at the maximum frequency (P06) or at the frequency just set, displaying the number of pulses performed.

g) When the desired suction volume is reached, press the ON/OFF to stop the procedure.

h) The pump proposes as sucked volume the injection volume previously entered in P16, multiplied for the number of performed pulses.

S	u	c	k	e	d		V	o	l	.	
			1	1	1		c	c			

i) Read the true sucked volume on the beaker as difference between the starting value (e.g. 200 ml) and the final one, adjust the displayed value with the ↓↑ arrow keys and press MENU/OK to confirm.

j) The microcontroller divides this value by the number of performed pulses and displays the result, also showing the mechanical stroke setting (P17)

k) If you are sure of read values and stroke position, press MENU/OK to confirm the result, which is then stored in P16.

l) If the ESC key is pressed during calibration, the procedure is aborted, and the previous value is kept in memory.

Notes:

- To avoid gross errors in volume reading, the internal geometry of the beaker must not change during procedure. The drawing shows the starting level (max) and the final level (min ok). Please note that a minimum level at the height of the foot filter, would imply an error.
- An alternative procedure, rarely used because not practical, is to weight the sucked liquid.
- If high dosage accuracy and precise flow rate / litre counter visualizations are required, this procedure must be performed at least every two months, in order to compensate the adaptation processes and sealing wear.
- Perform this calibration after each maintenance of hydraulic parts.

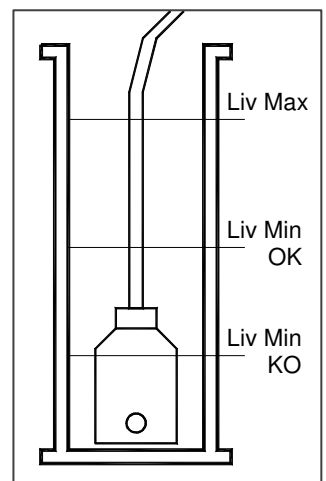

DosingPump.ir

ERRORS AND ALARMS

When an error or alarm occurs, the POWER LED blinks fast, and the display shows on the bottom line the related error message. If several errors are active, a sequence of all related messages is displayed. List of the possible messages:

Start mm:ss	Pump just started. The displayed time (in minutes : seconds) is the countdown of the start-up delay (parameter P34). Once this delay has elapsed, the message disappears, and the pump starts normal operations.
Level!	Fault signal from level probe. Add liquid in suction tank.
Manual stop	The ON-OFF key has been pressed.
Consent !	No consent / flow signal to the pump. Check the device connected to this input.
Tech. Service	Request of maintenance. This message is generated when the maximum limit of injectable litres (parameter P18) has been exceeded. After performing maintenance, remember to reset the litre-counter (parameter P19).
Max dosing	The pump is dosing for longer than the time set in P20, without reaching the required threshold. The error disappears by pressing twice the ON-OFF key. Check the general conditions of pump, system, and product to be injected. Also try to increase the set maximum dosing time.
Config. Error	The user has entered wrong data for the dosing control. For example, a too narrow proportional band has been set (see P11), or a minimum frequency too close or greater than the maximum (see P6 and P7). If this error occurs, the adjustment is approximated to the one required (for example the proportional band is enlarged).
Inject. Volume Err.	During injection volume calibration, a too small or too high value for the sucked volume has been entered. Repeat the procedure.
Time sequence	The clock feature for timed operation has been enabled but no On / Off times have been set (or wrong setting). Properly set the related parameters (advanced configuration menu).
Cal. Impossible!	Calibration error. See related section for further details.
UR / OR	In case of pump with analogic input, this message indicates a wrong input signal. The message is shown in the display area normally occupied by the measurement. See related section for further details. This fault condition generates an alarm and stops dosage.

Temperature Control

In the case of prolonged operation of the pump at maximum frequency (180 pulses/minute) and under unfavourable environmental conditions (near the maximum allowed temperature), the magnet operating the diaphragm may overheat.

To avoid possible damages, when the pump rate is greater than 80% (about 140 pulses/minute), the microcontroller decreases it forcedly for a short time, to cool the magnet. During rate reduction, a “R” appears in the display near frequency and flow rate visualizations. This status is not considered an error or alarm.

SERIAL LINE (optional)

The pump may feature an RS485 serial line for communication with terminals, PC or advanced PLC. For an easier understanding, the supervisor will be called “Master”. If the pump is connected to a PC on which an “HYPERTERMINAL” (or similar) program is running, on the “Master” display appears exactly the response of the pump to the received command.

Whatever the rate set with parameter P41 (see “Configuration” section), the standard transmission parameters are: **8 BITS, NO PARITY, 1 STOP BIT**.

The pin-out of the M8 connector is described in the “Electrical Connections” section.

Communication can be of **ASCII** type without protocol or with **Modbus RTU** protocol.

ASCII

In case of no protocol, the communication is performed through standard ASCII codes without any protocol and without control characters. Messages sent over the serial line have been designed to be as simple and intuitive as possible. The pump automatically sends to the “Master” the following messages:

PSP16x vv.vv at start-up (**16x** indicates the pump model, **vv.vv** indicates the software version)

Saved when an extremely low voltage or pump shutdown is detected.

The pump answers to the following commands

Command	Effect / Answer
HH	Help of commands
M1	Show analogic measurement (if any)
M2	Pump frequency (pulses/minute)
M3	Internal temperature
Pxxx	Read Parameter xxx value
Pxxx = YYYY	Write the value YYYY in the parameter xxx
RR	Microprocessor reset (reboot)
SS	Alarm status and pump frequency
ZZ	Reset offset/gain values (and reboot)
LL	Values of partial and total litre-counters
CC	Membrane shots and working life since last replacement

Notes:

- There are also other adjustment / calibration commands used only at the factory.
- Each command must be confirmed by pressing <CR> (or <ENTER>).
- All serial line messages are fixed and are not affected by the language set for the display.
- Typing mistakes in a command cannot be corrected. Send the wrong command (which will have no effect) and then enter the correct one.

Only for expert users who want to connect the pump to their own supervisor system:

Configuration procedure of the serial line:

- 1) Connect the supervisor (e.g. a PC) to the serial line plug, paying attention to the wiring instructions (see “Electrical Connections” section).
- 2) Set the supervisor to the right speed, 8 bits, 1 stop bit, no parity.
- 3) If the supervisor sends the command **Pxx (CR)**, the pump answers with the value of parameter “xx”
- 4) If, instead, the supervisor sends the command **Pxx=1234 (CR)**, the pump reads the four digits following the “=” sign as the new value of the parameter “xx”.

Notes:

- All values are without comma.
- The pump saves the value without checking it; limits must be checked by the supervisor.
- Commands through serial line may be either uppercase or lowercase.
- The “Cancel” command is not active; if a wrong value is sent, you must rewrite it.
- After any modification of the parameters, reboot the pump with the “**RR**” command to load the new values in the pump memory.

DosingPump.ir

MODBUS RTU

In this case, the communication takes place through the standard protocol by Modicon (<http://www.modbus.org/>). Data exchange is performed via “holding registers”, allocated as follows:

Command	Register No.	No. of registers	Action	Result
Read 0x03	1...56	1..16	Read registers	Value of related parameter
Write 0x06	1...56	1	Write the single register	Value of related parameter
Read 0x03	101	1	Read the single register	Current value of measurement
Read 0x03	102	1	Read the single register	Current value of the pump working frequency [pulses / minute]
Read 0x03	103	1	Read the single register	Current value of internal temperature
Read 0x03	100	3	Read 3 registers (101..103)	Values indicated above
Read 0x03	121	1	Read the single register	Current status of inputs #1
Read 0x03	122	1	Read the single register	Current status of outputs #2
Read 0x03	123	1	Read the single register	Current status of alarms #3
Read 0x03	121	3	Read 3 registers (121..123)	Status of inputs / outputs / alarms
Read 0x03	141	1	Read offset (for analogic pump)	Offset value
Write 0x06	141	1	Forcing offset (for analogic pump)	Offset value
Read 0x03	145 146	2	Read the time since last offset calibration (for analogic pump)	HR145 = Hours since last offset cal. HR146 = Minutes since last offset cal.
Read 0x03	151	1	Read gain (for analogic pump)	Gain value
Write 0x06	151	1	Forcing gain (for analogic pump)	Gain value
Read 0x03	155 156	2	Read the time since last gain calibration (for analogic pump)	HR155 = Hours since last gain cal. HR156 = Minutes since last gain cal.
Read 0x03	190...193	4	Read time	HR190 = day of the week HR191 = hours HR192 = minutes HR193 = seconds
Write 0x10	190...193	4	Set time	HR190 = day of the week HR191 = hours HR192 = minutes HR193 = seconds
Write 0x06	201	1	Update parameters	Enter value 123 to execute the command
Write 0x06	202	1	Reset micro	Enter value 123 to execute the command
Read 0x03	210 211	2	Read membrane strokes	Value of the stroke-counter (in DWord, 210=MSB, 211=LSB)
Write 0x10	210 211	2	Modify or reset the membrane strokes	Value of the stroke-counter (in DWord, 210=MSB, 211=LSB)
Read 0x03	212 213	2	Read the time since last membrane replacement	HR212 = Hours since last change HR213 = Minutes since last change
Read 0x03	214 215	2	Read litre-counter	HR214 = litres HR215 = centilitres
Write 0x10	214 215	2	Modify or reset the litre-counter	HR214 = litres HR215 = centilitres

DosingPump.ir

#1: Encoding of the status of the inputs (HR121):

Bit 0 (weight 1) = Level
Bit 1 (weight 2) = External consent (or pulse)
Bit 2 (weight 4) = Injection flow

#2: Encoding of the status of the outputs (HR122):

Bit 0 (weight 1) = The pump is dosing (cannot be used in case of proportional control)

#3: Encoding of the alarms (HR123):

Bit 0 (weight 1) = No level signal
Bit 1 (weight 2) = Injection flow alarm
Bit 2 (weight 4) = No external consent (no flow to the sensor, for analogic input version)
Bit 3 (weight 8) = Manual stop
Bit 4 (weight 16) = Measurement error (analogic input version only)
Bit 5 (weight 32) = Start delay
Bit 6 (weight 64) = Stop for timed dosage
Bit 7 (weight 128) = Maintenance request
Bit 8 (weight 256) = Self-priming in progress
Bit 9 (weight 512) = Max internal temperature (max frequency is reduced)
Bit 10 (weight 1024) = Max dosage time

The unused bits are always zero.

Notes:

- All registers are 16-bit.
- All values are without comma (therefore they must be correctly interpreted by the "Master").
- Parameters can be read individually or in blocks, but it is not possible to write more than one parameter at a time.
- Any commands not included in the above table do not give any answer / effect.
- To avoid any interference on the bus, choose a unique address (P42) for each pump connected.

ADDITIONAL VISUALIZATIONS

This menu allows to display some specific parameters, whose list can be scrolled by using the arrow keys ↑↓.

SW Version / Time

Version of the pump software, current day and time.

P	S	P	1	6	4		0	6	.	2	1
T	u	e		0	9	:	4	1	:	1	9

Mechanical Stroke

Displays the stroke length adjusted with the front knob (same value of parameter P17), which **must match the actual position of the knob**. If the stroke length is modified, this value must be immediately corrected, by proceeding as follows:

- press the MENU/OK key: the cursor appears below the stroke value
- use the arrow keys ↑↓ to set the correct value
- press MENU/OK to confirm the new value

Frequency / Flow Rate

Displays the actual values of working frequency and flow rate, in **pulses/min** and **litres/h** (calculated value, as a function of injection volume).

Partial Litre-Counter

This is the litre-counter value which can be used for programming service / maintenance requests. It is displayed on the first line, with a maximum limit value of 65'000 litres.

If a service value has been set (see P18), the countdown of the injectable litres before a service request, is shown on the second line (within brackets and with negative sign), for providing an indication about the pump autonomy before maintenance. When the limit set in P18 is exceeded, the "Service" warning message is displayed.

If P18 = 0 (no service request), the second line will remain empty.

The litre-counter can be reset by entering the correct password in P19 (see the "Configuration" section for details).

Relay / FLW

The status of the output relay is displayed. Possible indications: ON, OFF or □ (pulse) symbol. **Warning! This visualization does not automatically imply the existence of this option!**

In case of injection flow control enabled, the bottom line displays the possible pulse reception error of the sensor compared to the magnet shots. If this control is not used (P13 = Excluded), this info is not provided.

Internal Temperature

This value is used by the processor to avoid pump overheating. See the "Errors / Alarms" section for further details.

Offset

Correction factor of the scale initial value. The indication is qualitative: **Excellent, Good, Acceptable, Insufficient**.

Gain

Correction factor of the amplification, given qualitatively as for the offset.

“SERVICE” MENU

This menu is intended for skilled technicians and is protected by a fix password (communicated to the authorized technicians only), and allows the visualization of some special and important parameters, whose list you can scroll by using the arrow keys ↑↓.

Stop Time

When the pump stops operating for any reason, the processor starts count the stop time (in days, hours, minutes).

	S	t	o	p		T	i	m	e		
	0	d	,	1	9	h	,	1	3	m	

This value can be useful to know for how long the pump is not dosing. As soon as the pump stop conditions disappear, this counter resets automatically.

Membrane Life

Displays the membrane working life since last replacement (expressed in days, hours, minutes).

	M	e	m	b	r	a	n	e			
	1	2	d	,	1	9	h	,	1	m	

Membrane Shots Reset Membrane?

Counter of membrane shots since last replacement.

After replacing the membrane, the authorized technician has to access to this menu item and press MENU/OK to reset the counters of membrane working life and shots.

Total Shots

This is an internal counter, that starts counting at the factory test of the pump.
Cannot be reset.

Size

Displays the pump “size” (flow rate) at the electronic test. This value is used by the microcontroller for calculating the correct pulse to the magnet and set the parameter P16 (injection volume). Then, at the first calibration of the injection volume or if P16 is manually set, this pre-setting is overwritten.

Offset

Correction factor of the scale initial value, in points.

Gain

Correction factor of the amplification, given as multiplication factor compared to the calibration theoretical value.

Notes:

- Since the shot-counters may reach very high values (several millions), for ease of reading, on the digits of thousands and millions is displayed a small dot.
- The Offset and Gain values are important to verify the performance of the measure sensor connected to the analogic input. In general, the more the Offset value is close to zero, the better are the sensor conditions. Similarly, the Gain value should be close to 1.000. The minimum and maximum are listed here below:

Conductivity input	Offset: -100 ... 100 points
	Gain (multiplication factor): 0.750 ... 1.500
- The counters of membrane working life and shots do not generate any alarm or warning. In fact, the membrane life depends on several stress factors and cannot be exactly foreseen, but only supposed thanks to the experience.

MAINTENANCE

The periodic maintenance is of fundamental importance for the good functioning of the pump and its duration over time. Should be performed in a systematic and precise way, following all the indications given here below.



The pump maintenance must be carried out ONLY by qualified technicians and using ONLY original spare parts!

Pump Decommissioning



Thoroughly clean the pump housing, dosing head and the whole dosing line (see next paragraph for details).

Take all necessary personal protective measures, also depending on the feed chemical.

- Ensure that the system is depressurized.
- Disconnect the pump from the mains.
- Empty the head by turning it upside down and draining off the dosing product.
- **Rinse the head with an appropriate liquid, taking special care if the pump has been used for dosing hazardous products.**
- In case of temporary decommissioning, respect the correct storage conditions: ambient temperature from -10 to +50 °C and RH max 92 %.

Periodic Cleaning of the Hydraulic Group

Recommended average frequency: once a month.

The entire dosing line must be cleaned: foot filter, suction line hose, suction valve, drain nozzle, bleed valve, dosing head, delivery valve, delivery hose, injection valve.

This operation is performed by first flowing clean water and then a dilute acid solution, for example 3% hydrochloric acid solution.

Periodic Checks

In case of normal use of the pump (about 30% of continuous operation), it is advisable to perform the following **checks every three months**. In case of higher stress (for example, continuous operation), a shorter interval is recommended.

- Check the integrity of the diaphragm (if dosing products that can damage the membrane, as abrasive additives, check more often)
- Check that the suction and delivery hoses are securely attached to the pump
- Ensure that there are no bottlenecks in the delivery pipe
- Check that the suction and delivery valves are secure
- Check the tightness of the dosing head, verifying that no liquid leaks from the drain hole (see figure)
- Check the integrity of electrical connections
- Ensure that the pump housing is intact
- Check that the head bolts are tight (if necessary, apply a torque of 2 Nm)
- Check the functioning of the purge valve

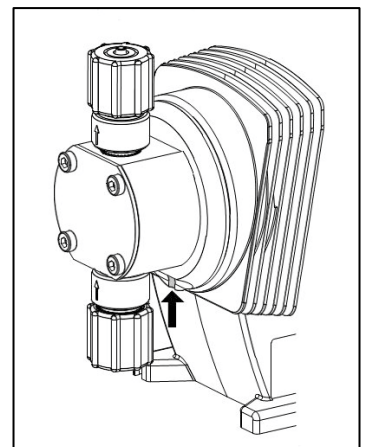

Drain hole.

Weekly Checks

- Check the feed liquid level in the suction tank
- Check that there are no impurities or dirt in the suction and injection hoses
- Check the foot filter for clogging, that can cause the decrease of flow rate

Cleaning Service and Replacement of Wearing Parts



Attention to dosed chemicals! Before any operation on the pump, discharge the liquid from the pump head and pipes. Take all necessary personal protective measures (i.e. gloves and goggles), as indicated in the SDS of the chemical, which must be always available and updated.



Before any intervention, unplug or disconnect the pump from the mains. Depressurize all the hydraulic components of the plant.

Also refer to the exploded view of dosing heads, available in the relevant section of this manual.

Valve Cleaning

In case of pump malfunctioning, proceed with the cleaning of suction and delivery valves, by disassembling them one by one so as not to exchange the pieces.

After this operation or valve replacement, it is necessary to recalibrate the pump.

- Using an Allen key (or similar tool), enter through the small connecting hole and push out the valve inserts.
- Pay attention to the flow direction of the fitting, that is different for suction and delivery.
- In case of dosing head with 0216 and 0510 flow rates, please note that:
 - The inserts of suction and delivery valves are identical.
 - Under the inserts there is a spacer.
 - In the dosing head is placed a shaped seal (not O-ring).
- In case of dosing head with 1304, 2002 and 3202 flow rates, please note that:
 - The shaped seal must be inserted in the suction fitting.
 - In the dosing head is placed only the O-ring (not the shaped seal).

Membrane Replacement

- Empty the head by turning it upside down and draining off the dosing product; then rinse with an appropriate liquid.
- While the pump is working, put the stroke adjustment knob on 0%, so that the motor shaft can hardly move.
- Switch off the pump.
- Unscrew the hydraulic fitting on both delivery and suction sides.
- Remove the purge valve and using a screwdriver lift the head cover.

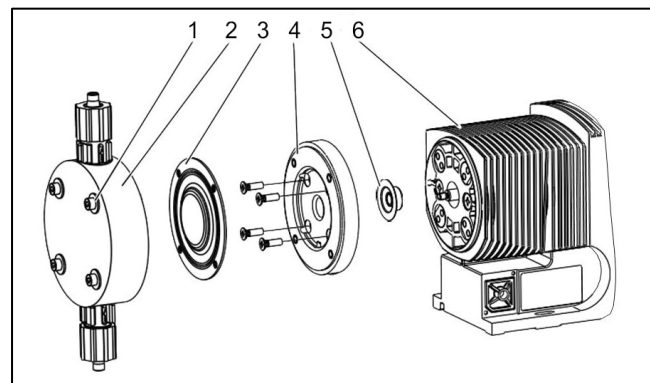
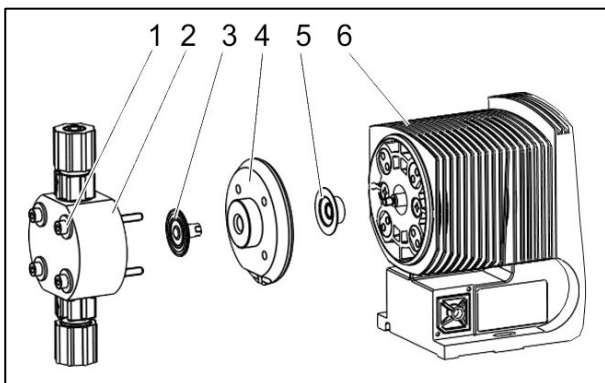

- | | |
|----------------|--------------------|
| 1. Screws | 4. Head disc |
| 2. Dosing head | 5. Safety membrane |
| 3. Membrane | 6. Pump housing |

- In case of dosing head with 0216, 0510 and 1304 flow rate:
 - Remove the screws (1).
 - Loosen the dosing head (2) and the disc head (4) from the pump housing (6).

- Hold the pump housing (6) with one hand and using the other one grab the membrane (3), located between the dosing head (2) and the dosing disc (4).
- Loosen the membrane (3) from the motor shaft, by slightly twisting counterclockwise the dosing head (2) and the head disc (4).
- Completely unscrew the membrane (3) from the motor shaft.
- Remove the head disc (4) from pump housing (6).
- Check the safety membrane (5) and, if necessary, replace it.
- Push the safety membrane (5) on the motor shaft until it is thoroughly flat over the pump housing (6); do not push it over!
- Carefully screw the new membrane (3) until it locks on the motor shaft.



Warning! *This operation must be carried out accurately, for ensuring a correct dosage of the pump.*

- The membrane (3) should be placed on the thread stop. If not, remove any dirt or shavings from the thread and correctly tighten the membrane (3) on the motor shaft.
- Tighten the membrane (3) one more time.
- Correctly place the head disc (4) on the pump housing (6), paying attention to not deform the safety membrane (5).



Warning! *The drain hole must point downwards when the pump is fully assembled.*

- Place the membrane (3) on the head disc (4).
- Hold tightly the head disc (4) and screw the membrane (3) by turning it clockwise until it fits in its place (you will notice the resistance of the return spring).
- Adjust the stroke length at 100%.
- Place the dosing head (2) with the screws (1) on the membrane (3) and on the head disc (4). The suction fitting must point downwards when the pump is fully assembled.
- Slightly screw the bolts (1), then tighten crosswise and applying a torque of 2 Nm.



*Check the screw torque after 24 hours of operation!
Check again after three months.*

- Correctly place the head cover and push the purge valve knob to insert it in place.

▪ In case of dosing head with 2002 and 3202 flow rates:

- Remove the dosing head (2) with the screws (1) from the pump.
Warning! Only for model 3202, remove the screws of the head disc (4) under the membrane (3), then reattach the pump head (2) with the screws (1) which should enter the membrane (3) holes, but not in the head disc!
- Hold the pump housing (6) with one hand and using the other one grab the membrane (3), located between the dosing head (2) and the dosing disc (4).
- Loosen the membrane (3) from the motor shaft, by slightly twisting counterclockwise the dosing head (2) and the head disc (4).
- Remove the pump head (2) with the screws (1) from the membrane (3) and completely unscrew it from the motor shaft.
- Remove the head disc (4) from the pump housing (6).
- Check the safety membrane (5) and, if necessary, replace it.
- Push the safety membrane (5) on the motor shaft until it is thoroughly flat over the pump housing (6); do not push it over!
- Carefully screw the new membrane (3) until it locks on the motor shaft.



Warning! *This operation must be carried out accurately, for ensuring a correct dosage of the pump.*

- Check that the membrane holes match the holes on the pump housing (6). If not, start the pump and adjust the stroke length at 100%.

DosingPump.ir

- While the pump is working, slowly turn the membrane (3) clockwise until the four holes on the membrane match those on the pump housing (6).
- Hold tightly the membrane (3) in this position, adjust the stroke length at 0% and stop the pump.
- Tighten the membrane (3) one more time.
- Correctly place the head disc (4) on the pump housing (6), paying attention to not deform the safety membrane (5).

Warning! Only for model 3202, secure the head disc (4) with its screws.



Warning! *The drain hole must point downwards when the pump is fully assembled.*

- Place the membrane (3) on the head disc (4).
- Hold tightly the head disc (4) and screw the membrane (3) by turning it clockwise until it is fixed in its place (you will notice the resistance of the return spring).
- Place the dosing head (2) with the screws (1) on the membrane (3) and on the head disc (4). The suction fitting must point downwards when the pump is fully assembled.
- Slightly screw the bolts (1), then tighten crosswise and applying a torque of 2 Nm.



*Check the screw torque after 24 hours of operation!
Check again after three months.*

- Correctly place the head cover and push the purge valve knob to insert it in place.

Disposal of the Pump

Thoroughly clean the pump housing and dosing head, by taking all necessary personal protective measures, also depending on the feed chemical.



Electrical scrap is a special waste!
Comply with all applicable regulations for proper disposal.

EXPLODED VIEW OF DOSING HEADS

PKT pump head (PVDF parts with ceramic ball valves and PTFE seals)

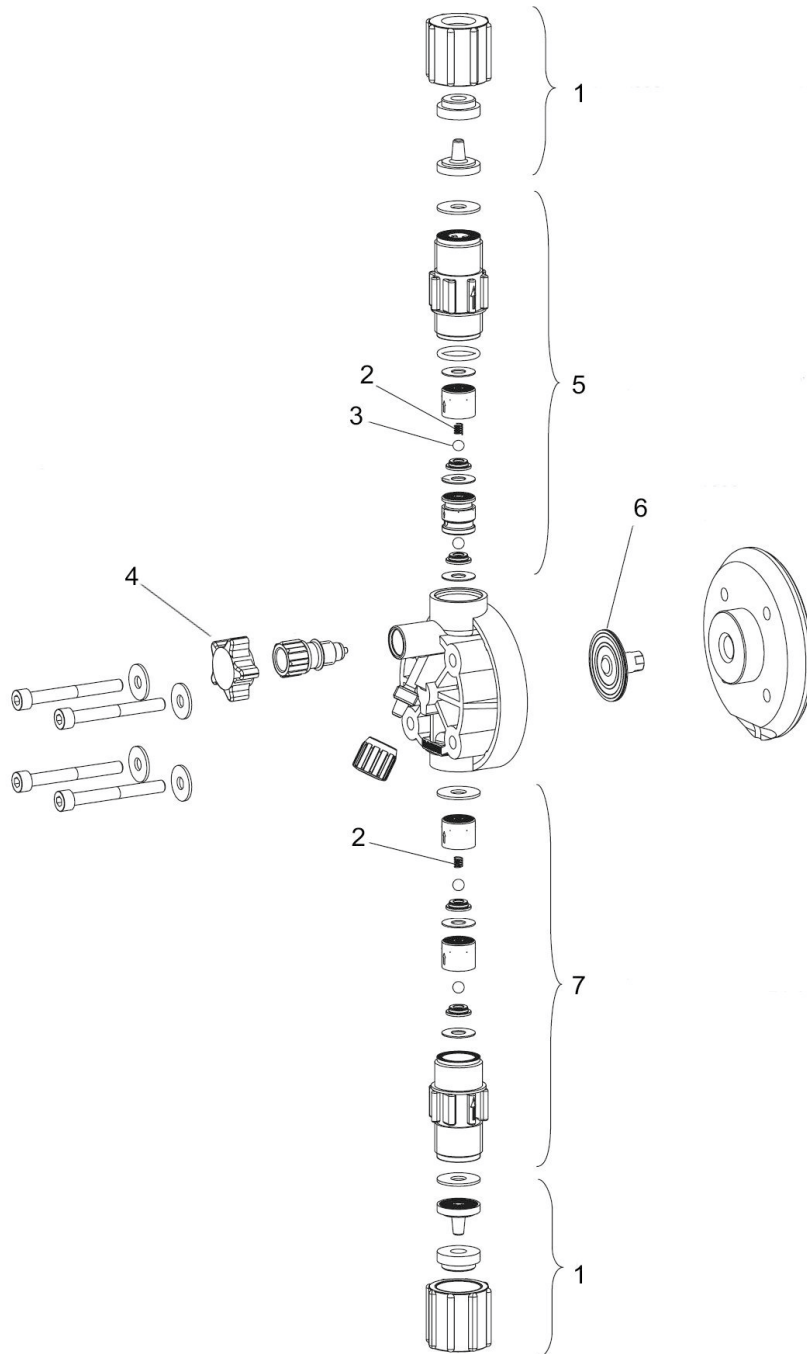

1	Connection kit, including threaded ring, locking ring and hose-holder nozzle
2	Spring (special accessory, valves for dosing viscous liquids up to 500 mPa•s)
3	Ceramic ball
4	Purge valve
5	Complete delivery valve
6	Dosing membrane
7	Complete suction valve

DosingPump.ir

MKV pump head (methacrylate body, PVC valves with ceramic ball, FPM seals)

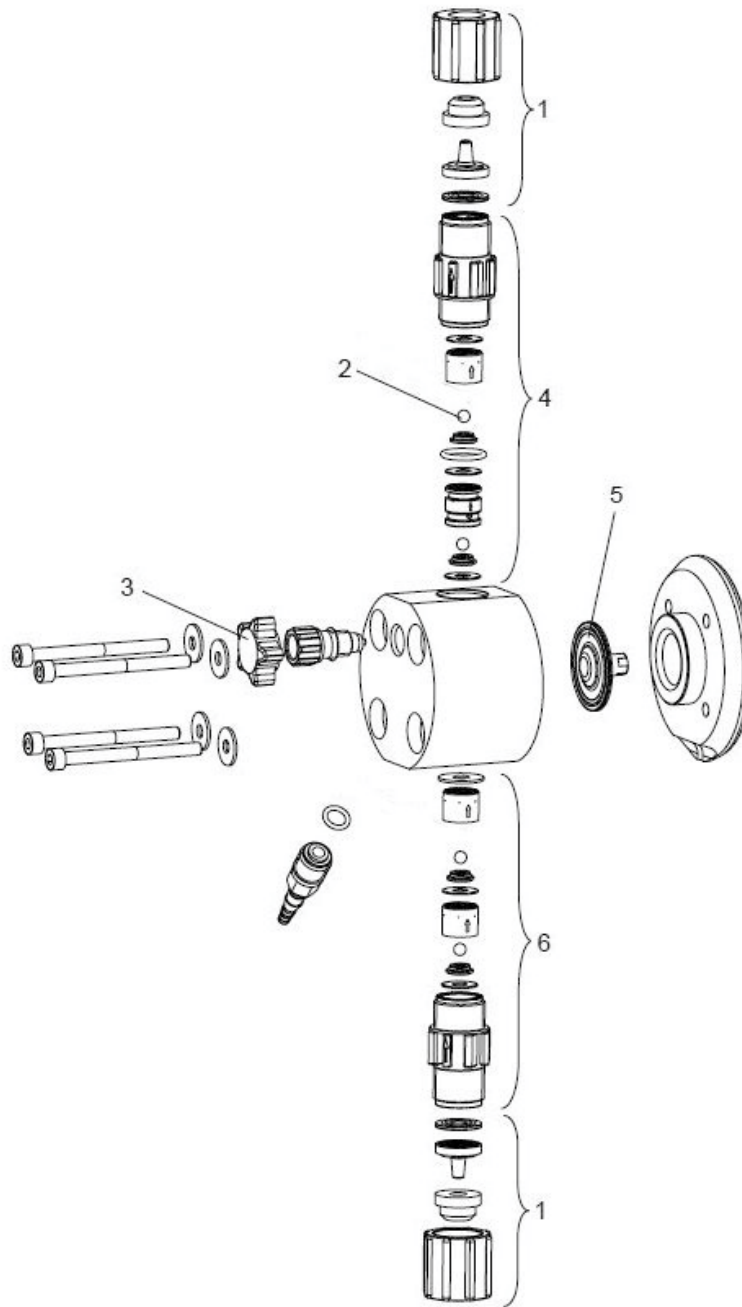

1	Connection kit, including threaded ring, locking ring and hose-holder nozzle
2	Ceramic ball
3	Purge (and vent) valve, with adjustment screw (*)
4	Complete delivery valve
5	Dosing membrane
6	Complete suction valve



(*) If necessary, adjust this screw properly.

DosingPump.ir

ACCESSORIES AND SPARE PARTS

Item, Description	Part No.
Accessory kit for full maintenance of pump head, 0216 PKT	97003000/PKT
Accessory kit for full maintenance of pump head, 0510 PKT	97003001/PKT
Accessory kit for full maintenance of pump head, 1304 PKT	97003002/PKT
Accessory kit for full maintenance of pump head, 2002 PKT	97003003/PKT
Accessory kit for full maintenance of pump head, 3202 PKT	97003004/PKT
Membrane 0216	97003010
Membrane 0510	97003011
Membrane 1304	97003012
Membrane 2002	97003013
Membrane 3202	97003014
Foot filter with connection for hose 4x6, PKT	97003020/PKT
Foot filter with connection for hose 5x8, PKT	97003021/PKT
Foot filter with connection for hose 9x12, PKT	97003022/PKT
Injection valve with connection for hose 4x6, PKT	97003030/PKT
Injection valve with connection for hose 5x8, PKT	97003031/PKT
Injection valve with connection for hose 9x12, PKT	97003032/PKT
Hose 4x6 in PVC Crystal, sold by meter	36502103
Hose 5x8 in PVC Crystal, sold by meter	36502106
Hose 9x12 in PVC Crystal, sold by meter	36502115
Hose 4x6 in PE, sold by meter	36501103
Hose 5x8 in PE, sold by meter	36501106
Hose 9x12 in PE, sold by meter	36501115
Hose 4x6 in PVDF, sold by meter	36505003
Hose 4x6 in PTFE, sold by meter	36506003
SLP3, level sensor with 2 m cable and axial (M8) connector	97009006
CAV2M8D, 4-wire cable with female M8 connector, 2 m	80099142
SMP18, mounting bracket with rotating support, for wall installation of PROXIMA PS pumps	97000504
Multi-function valve, bypass connection 4x6, opening pressure 16 bar	97003910
Multi-function valve, bypass connection 4x6, opening pressure 10 bar	97003911
Multi-function valve, bypass connection 4x6, opening pressure 6 bar	97003912
Signal splitter, 2 channels	80620001
Signal splitter, 4 channels	80620002

Note: Pump spare parts are also available with balls and / or seals of different materials. Contact the manufacturer for more info.

DosingPump.ir

CODING SYSTEM

This diagram allows to build the code of the pump with the desired characteristics.

Pump Model

987 PSP164 – Pump with inbuilt conductivity meter

Power Supply

- 0 100-240 V~ - cable with Schuko plug**
- 1 100-240 V~ - open cable (no plug)
- 2 100-240 V~ - cable with type B plug

Optional Outputs

- 0 No output**
- 1 Alarm relay
- 2 4-20 mA
- 3 Relay for pulse repetition
- 8 RS485 serial port with Modbus protocol

Inputs

- 2 Level + external consent**
- 4 Level + external consent + injection flow control

Colour

- A Dark grey front, light grey housing**

Dosing Head

- 2 PKT – PVDF with ceramic balls and PTFE (FPM, EPDM) seals**
- 3 PKT/AS – PKT with 2-way self-bleeding option (only flow rates 0216, 0510, 0516)
- 4 MKV – methacrylate with ceramic balls and FPM seals (only flow rates 0216, 0510, 0516)
- 5 PKT500-1 – PKT for dosing viscous liquids, up to 500 cP; for pumps with flow rate ≤ 5 l/h
- 6 PKT500-2 – PKT for dosing viscous liquids, up to 500 cP; for pumps with flow rate ≥ 8 l/h
- 7 PKT-HV – PKT for high viscous liquids up to 3000 cP; for flow rates ≥ 5 l/h (no 3202)
- 8 PTT – PVDF with PTFE balls and PTFE (FPM, EPDM) seals
- 9 PTT500-1 – PTT with spring for viscous liquids, up to 500 cP; for flow rates ≤ 5 l/h
- A PTT500-2 – PTT with spring for viscous liquids, up to 500 cP; for flow rates ≥ 8 l/h
- B PKTT/AS – PKT with “full PTFE” diaphragm and 2-way self-bleeding (LEGION pump)
- C MKV/AS – MKV with 3-way self-bleeding option (only for flow rate 0216)
- D MKVT/AS – MKV with “full PTFE” diaphragm and 3-way self-bleeding (only for 0216)

Flow Rate (l/h bar)

- | | |
|--------------------|--------------------|
| A 0216 (hose 4x6) | H 0425 (hose 4x6) |
| B 0510 (hose 4x6) | J 0516 (hose 4x6) |
| C 1304 (hose 5x8) | K 0807 (hose 5x8) |
| D 2002 (hose 9x12) | L 0810 (hose 5x8) |
| E 3202 (hose 9x12) | M 1307 (hose 5x8) |
| F 0310 (hose 4x6) | N 2004 (hose 9x12) |
| G 0416 (hose 4x6) | |

Range / Cell Constant

This field is used to specify measurement range and cell constant.
Contact the manufacturer for details.

Notes:

- **Customized versions are available upon request. Contact the manufacturer for further details.**
- *Options in bold characters refer to the standard version.*

DosingPump.ir