

SERIES 4 COMBINATION PUMPS

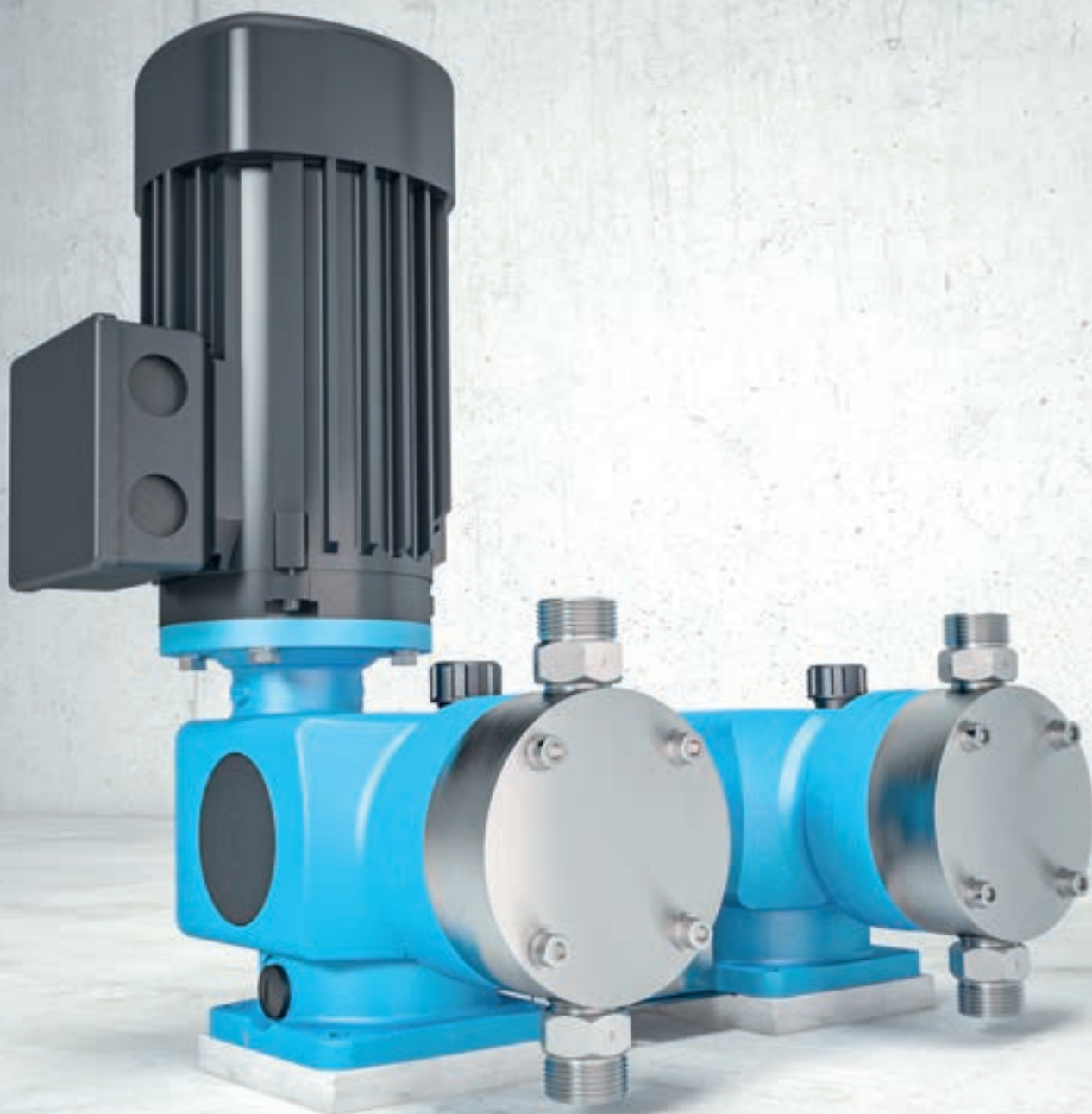

DosingPump.ir

COMBINATION PUMPS - THE ALLROUNDERS

A combination or multi-head pump is used precisely when the customer's requirements cannot be met with a single-head pump. For example, multi-head pumps are used for higher delivery rates that cannot be achieved by a single pump. Likewise, combination pumps enable pulsation-free delivery of the media without the need for fittings or pulsation dampers. In addition, combination pumps are ideal for running complicated formulations, with different dosing quantities and times.

AREAS OF APPLICATION

- High delivery rates
- For very low-pulsation metering tasks
- For different dosing rates in relation to each other
- Special recipes

APPLICATION EXAMPLES

- Power plant technology
- Paint and varnish production
- Beverage industry
- Textile industry
- and much more

ADVANTAGES AT A GLANCE

- Extremely low-pulsation conveying possible due to stroke offset
- Up to five heads possible, also in different conveying capacities
- Each head individually adjustable in conveying capacity
- Highest flexibility and accuracy
- Conveying of different media in one process

- Application range up to 7,500 l/h
- Modular system, high combination possibilities
- Leakage-free and long diaphragm service life
- High dosing accuracy
- Configurable with automatic flow rate adjustment
- Indication of diaphragm status by integrated diaphragm monitoring (optional)
- Excellent suction behaviour, without additional components
- Very high pressure range (with piston diaphragm pump)
- Low maintenance due to low-wear components

DosingPump.ir

VERSIONS

The following variants (types of construction/displacement) can be combined with each other. If no common piping is provided, single diaphragm pumps, for example, can also be combined with piston diaphragm pumps.

COMBINATION PUMP 409.2 e / 410.2 e

- max. five heads
up to max. 7,500 l/h

COMBINATION PUMP 409.2 ML / 410.2 ML

- max. five heads
up to max. 6,000 l/h

COMBINATION PUMP 409.2 KM / 410.2 KM

- max. five heads
up to max. 4,000 l/h

COMBINATION PUMP 409.2 K / 409.2 K

- max. five heads
up to max. 110 l/h



DIAPHRAGM PUMPS

The medium to be pumped is separated from the drive by a diaphragm. This protects the actuator from harmful influences of the medium. They are primarily used when leakage-free and exact dosing is required. For example, with aggressive, odorous, abrasive, radioactive, flammable, viscous or toxic media.



MULTI-LAYER DIAPHRAGM PUMPS

Multi-layer diaphragms can ensure the use of more demanding safety tasks, as diaphragm rupture signalling is used with a multi-layer diaphragm pump. Compared to single-layer diaphragms, the increased safety requirements are met by considerably improved diaphragm service lives. Areas of application are primarily wastewater and exhaust gas treatment.



PISTON DIAPHRAGM PUMPS

The stroke movement of the mechanically driven piston is transmitted hydraulically to the multi-layer diaphragm. An integrated balancing valve ensures excellent metering accuracy and provides optimum overload protection: in the event of an impermissibly high back pressure, the hydraulic fluid can escape into the balancing valve.



PISTON PUMPS

Piston pumps are versatilely applicable and despite its high pressure range extremely safe to operate. Due to low-wear components the maintenance of the piston pump is very low and therefore it convinces with accustomed quality and reliability.



DosingPump.it

MULTI-HEAD AND COMBINATION PUMPS FOR SPECIAL AND LOW-PULSATION TASKS

OVERVIEW

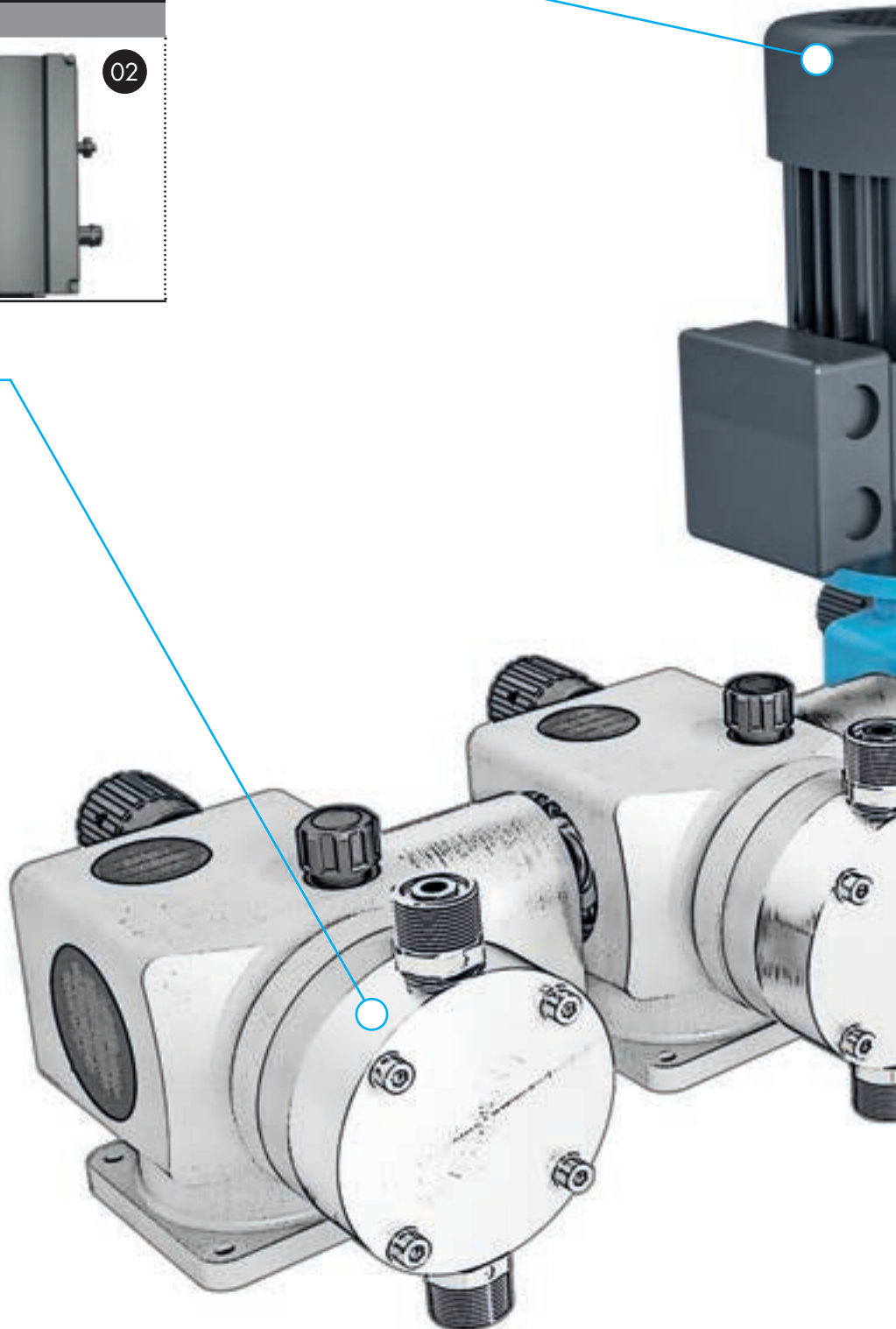
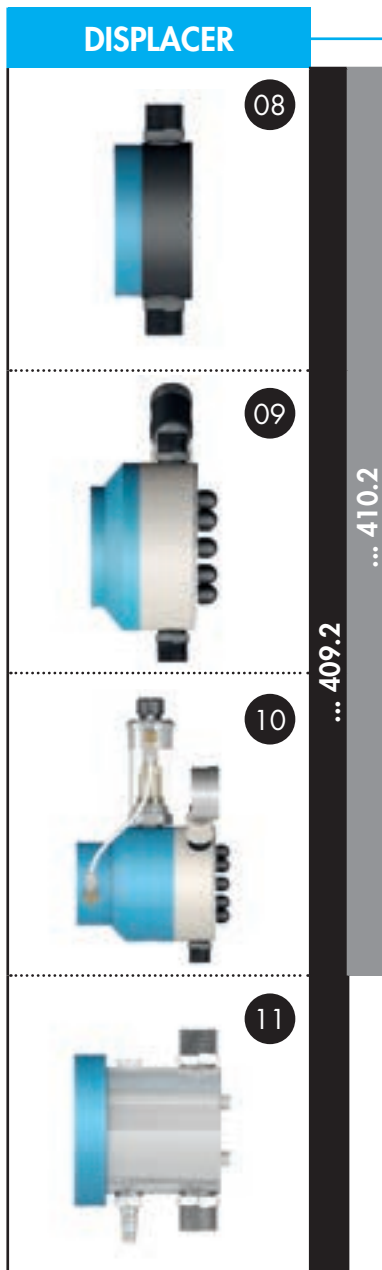
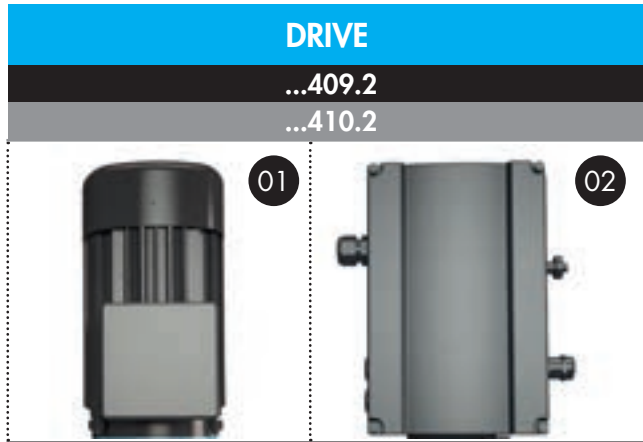

DosingPump.ir

INDIVIDUAL SOLUTIONS ON REQUEST

DRIVE

- 01 | Motor DSM / WSM
- 02 | Motor DSM with frequency converter

STROKE ADJUSTMENT

- 05 | Manual with simple scale
- 06 | Manual with position indicator
- 07 | Electrical with actuator

HOUSING TYPE

- 03 | 409.2
- 04 | 410.2

DISPLACER TYPE

- 08 | Single-layer diaphragm pump
- 09 | Multi-layer diaphragm pump
- 10 | Piston diaphragm pump
- 11 | Piston pump

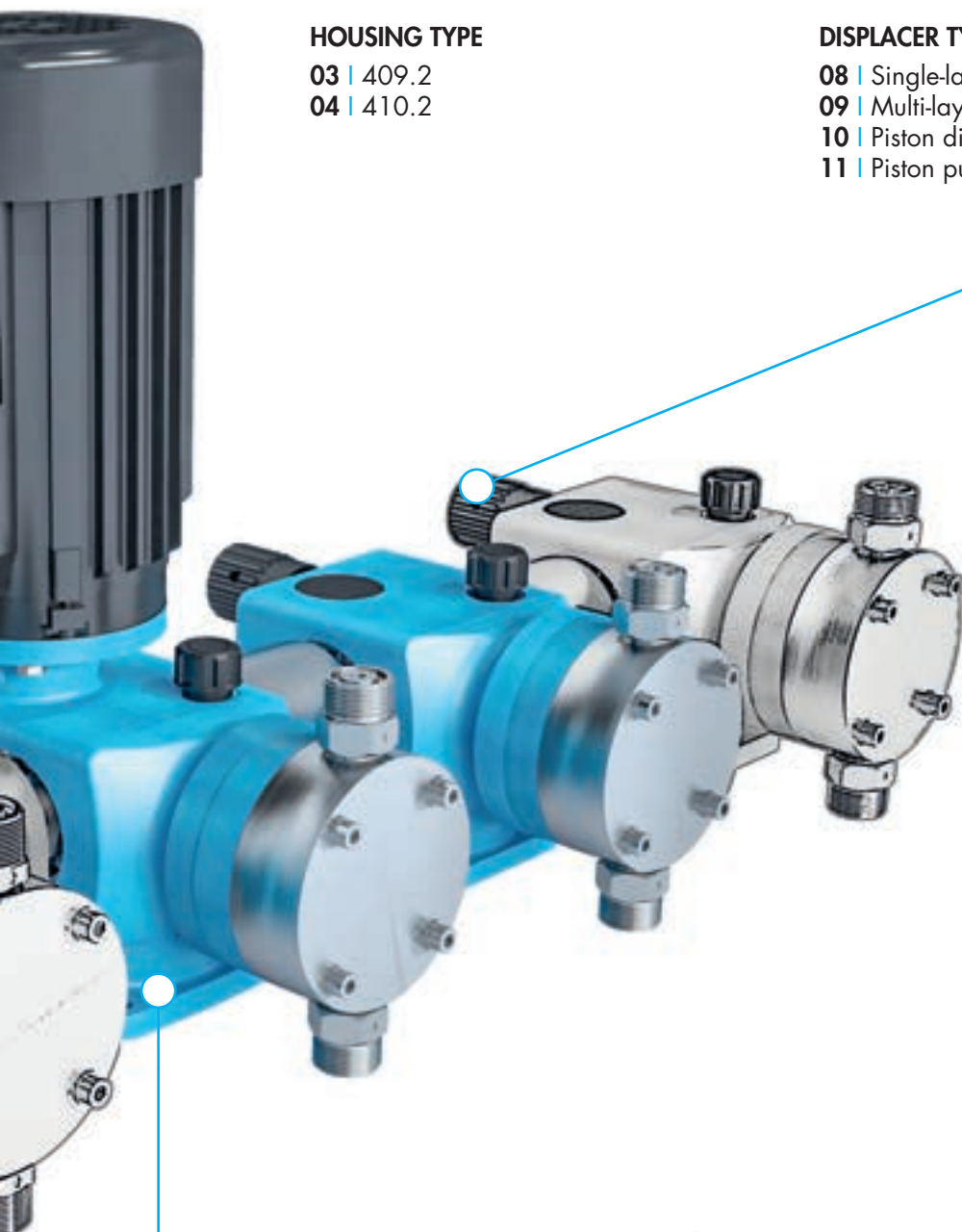

STROKE ADJUSTMENT



HOUSING

...409.2

...410.2

03

04



DosingPump.ir

ADDITIONAL FEATURES

FREQUENCY CONVERTER

The speed and thus the delivery rate of the dosing pump can be regulated without control electronics using a frequency converter.



STROKE FREQUENCY SENSOR

sera dosing pumps are oscillating displacement pumps with an exactly defined stroke volume for each pump stroke. The stroke frequency sensor records the individual pump strokes and forwards each individually to the evaluation unit.



ELECTRIC ACTUATOR FOR STROKE LENGTH ADJUSTMENT

Using the electric actuator for stroke length adjustment, this can be automatically adjusted by a control unit and manual adjustment is no longer needed.

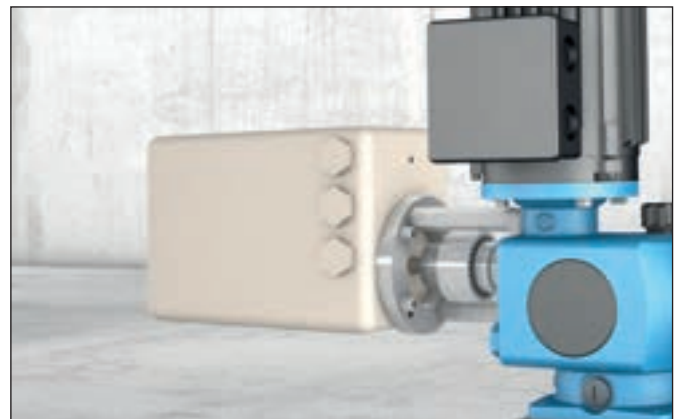

PUMP BODY WITH INTEGRATED PRESSURE RELIEF VALVE

(only for single diaphragm pumps)

The integrated diaphragm pressure relief valve protects the pump from unacceptable overpressure when the pressure pipe is closed. It can be used for low-viscosity media without solids for a maximum flow rate of 570 l/h.

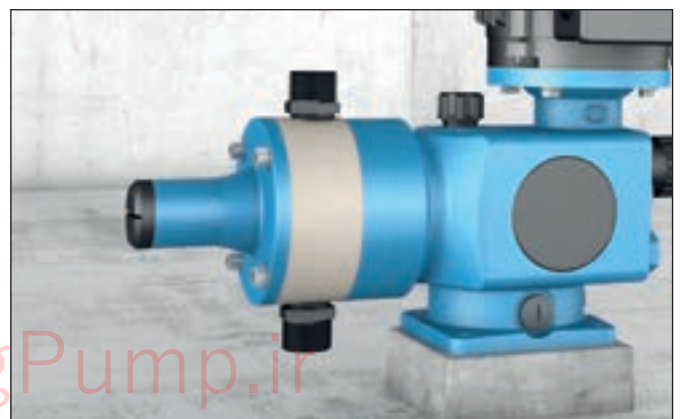

DosingPump.ir

ADDITIONAL FEATURES

DIAPHRAGM MONITORING

(only for single diaphragm pumps)

Conductive diaphragm monitoring is carried out via an electrode in conjunction with an evaluation unit. The electrode is installed in the base ring (behind the diaphragm). In addition, a relay is required for evaluation.



VISUAL DIAPHRAGM MONITORING WITH MANOMETER

(only for multi-layer and piston diaphragm pumps)

In the case of any damage of the working diaphragms, the pressurised medium flows through a hole to the signal manometer and causes a pointer deflection. The pump can continue to operate thanks to the multi-layer diaphragms.



DIAPHRAGM MONITORING WITH PRESSURE SWITCH

(only for multi-layer and piston diaphragm pumps)

In the case of any damage of the working diaphragms, a pressure is generated at the pressure switch. The pending signal can then be processed. The pump can continue to operate thanks to the multi-layer diaphragms.



MATERIALS

The high quality of the materials guarantees reliable continuous operation. The optimum material is available for every requirement.

PUMP BODY AND VALVES

PVC-U, PP, PVDF, PP-FRP, PVDF-FRP, 1.4571

VALVE BALLS

PTFE, 1.4401

VALVE SEALS

EPDM, FPM, FEP-covered

DRIVE DIAPHRAGM

PTFE-kaschiert

MANUAL VENTILATION VALVE

(only for single diaphragm pumps (409.2-2,4e))
PP-FRP, PVDF-FRP

DRIVE

The respective drive unit consists of a proven motor make, coupled with a lifting gear in a robust housing.

Sera housings can withstand even the toughest operating conditions. Material thickness and surface treatment resist even chemical attacks.

FLOW RATE

The flow rate is constant or infinitely variable. In the adjustable version, this is done manually by changing the stroke length. The automatic flow rate adjustment can be carried out via the following options:

- Three-phase motors suitable for frequency inverter operation for stroke frequency change via an external frequency inverter
- Servomotors with positioners for automatic stroke length change

SPECIAL DESIGNS

We offer individual solutions for special dosing tasks:

Among other things, pump bodies with special nominal diameters, heating devices, valves as double valves, with spring loading, with elastic ball seats, flushing devices for interval or final flushing to prevent deposits in the pump body, attachment of stroke rate sensors, diaphragm rupture monitoring, special materials such as titanium or Hastelloy, cleanable design.

ACCESSORIES

For optimal installation of dosing pumps, all necessary accessories such as overflow valves, pressure maintenance valves, pulsation dampers, dosing valves, dosing tanks, flow monitors, etc. can be ordered from us.

DosingPump.ir

TECHICAL DATA

The individual pump units of combination and multi-head pumps can be individually matched to each other, so that an overview of technical data is not meaningful here.

Due to the fact that different pump types and types can be combined with each other depending on the application, a precise design by sera application technicians is required.

The technical data of the different pump types and types of pumps in the respective product information serve as a basic aid:

(SINGLE)DIAPHRAGM PUMPS

Product Information **PI-2002**

Diaphragm pumps Series 4

[DOWNLOAD](#)

or scan QR-Code



MULTI-LAYER DIAPHRAGM PUMPS

Product Information **PI-2003**

Multi-layer Diaphragm Pumps Series 4

[DOWNLOAD](#)

or scan QR-Code



PISTON DIAPHRAGM PUMPS

Product Information **PI-2004**

Piston Diaphragm Pumps Series 4

[DOWNLOAD](#)

or scan QR-Code



PISTON PUMPS

Product Information **PI-2006**

Piston Pumps Series 4

[DOWNLOAD](#)

or scan QR-Code



DosingPump.ir

DIMENSIONS (EXAMPLE)

2-fold diaphragm combination pump R(F) 409.2-... / RK 409.2-...

Due to the many possibilities, this dimensional drawing is only to be considered as an example. In the individual case of application, a detailed dimensional drawing with all necessary dimensions will be prepared.

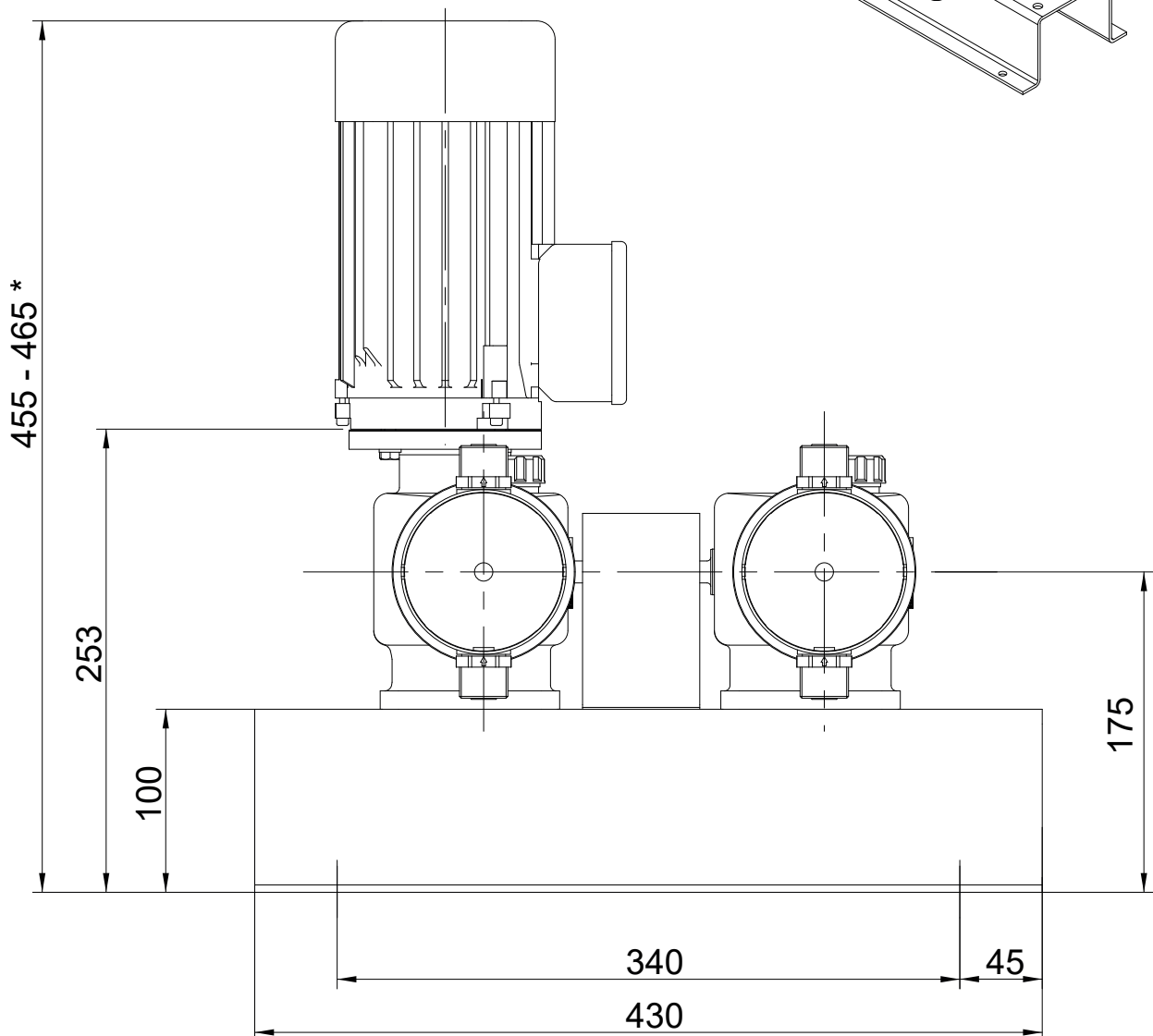
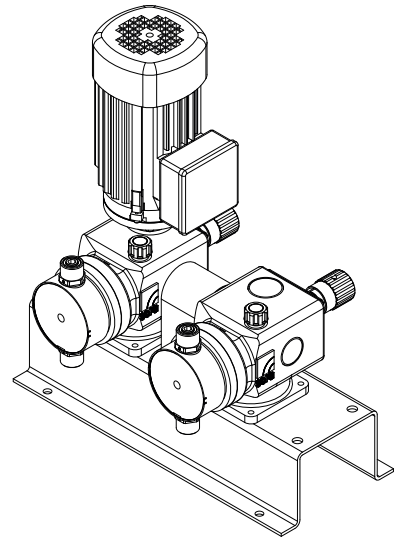

- * at 409.2-1,6e to -25e: 455 mm
- at 409.2-50e to -350e: 465 mm

DosingPump.ir

DIMENSIONS (EXAMPLE)

2-fold diaphragm combination pump R(F) 410.2-... / RK 410.2-...

Due to the many possibilities, this dimensional drawing is only to be considered as an example. In the individual case of application, a detailed dimensional drawing with all necessary dimensions will be prepared.

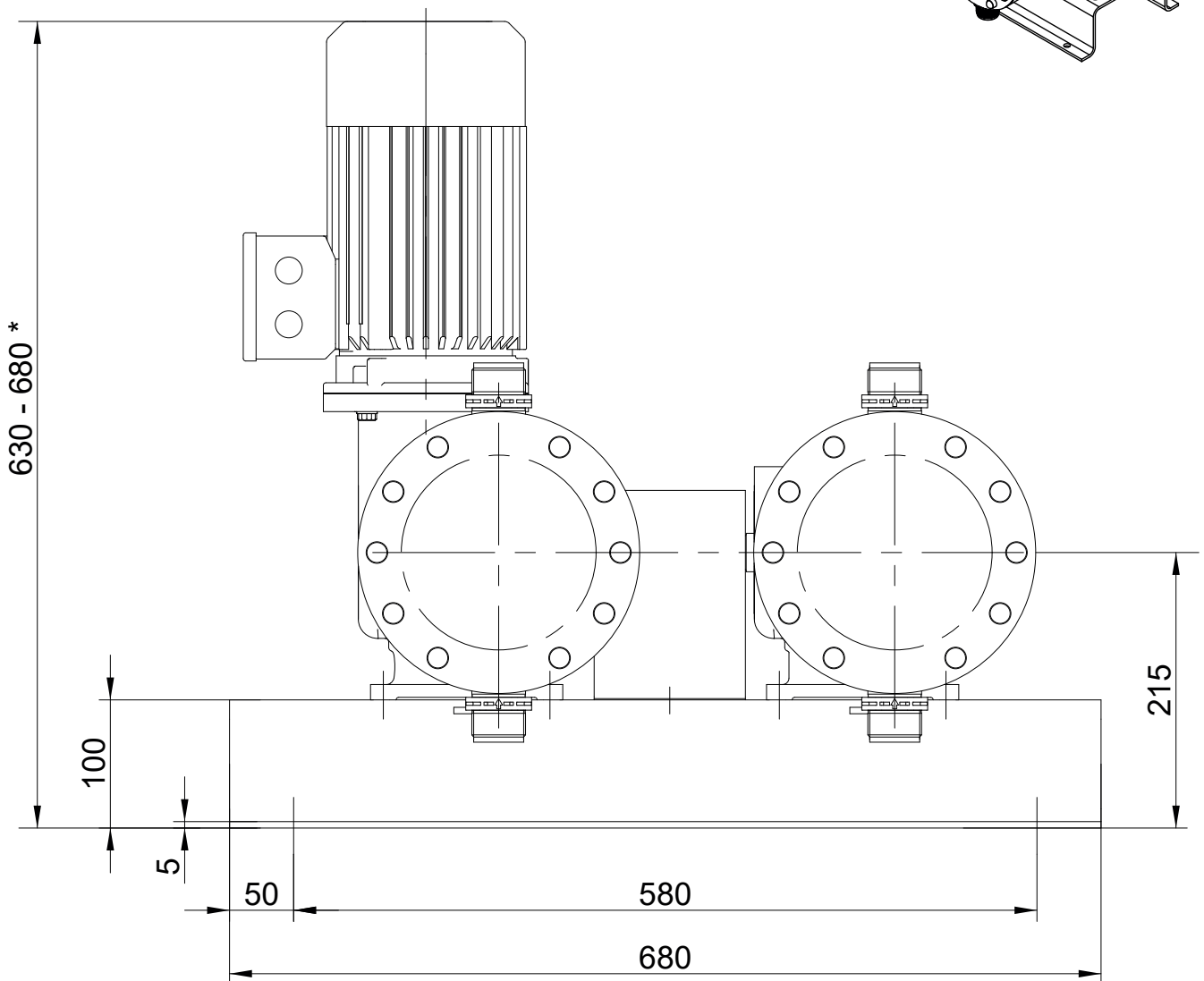
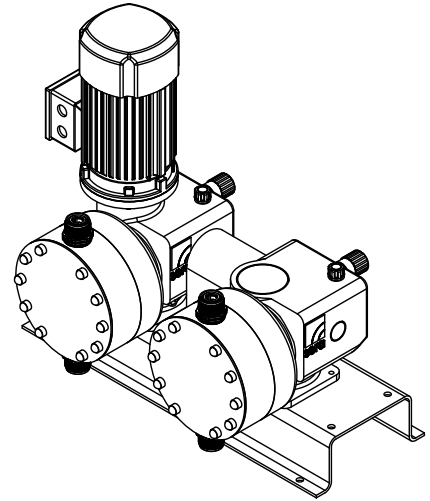

- * at 410.2-280e/-570e: 630 mm
- at 410.2-900e: 640 mm
- at 410.2-1450e: 680 mm

DosingPump.ir

DIMENSIONS (EXAMPLE)

3-fold piston diaphragm combination pump R(F) 409.2-KM / RK 409.2-KM / RK409.2-KM

Due to the many possibilities, this dimensional drawing is only to be considered as an example. In the individual case of application, a detailed dimensional drawing with all necessary dimensions will be prepared.

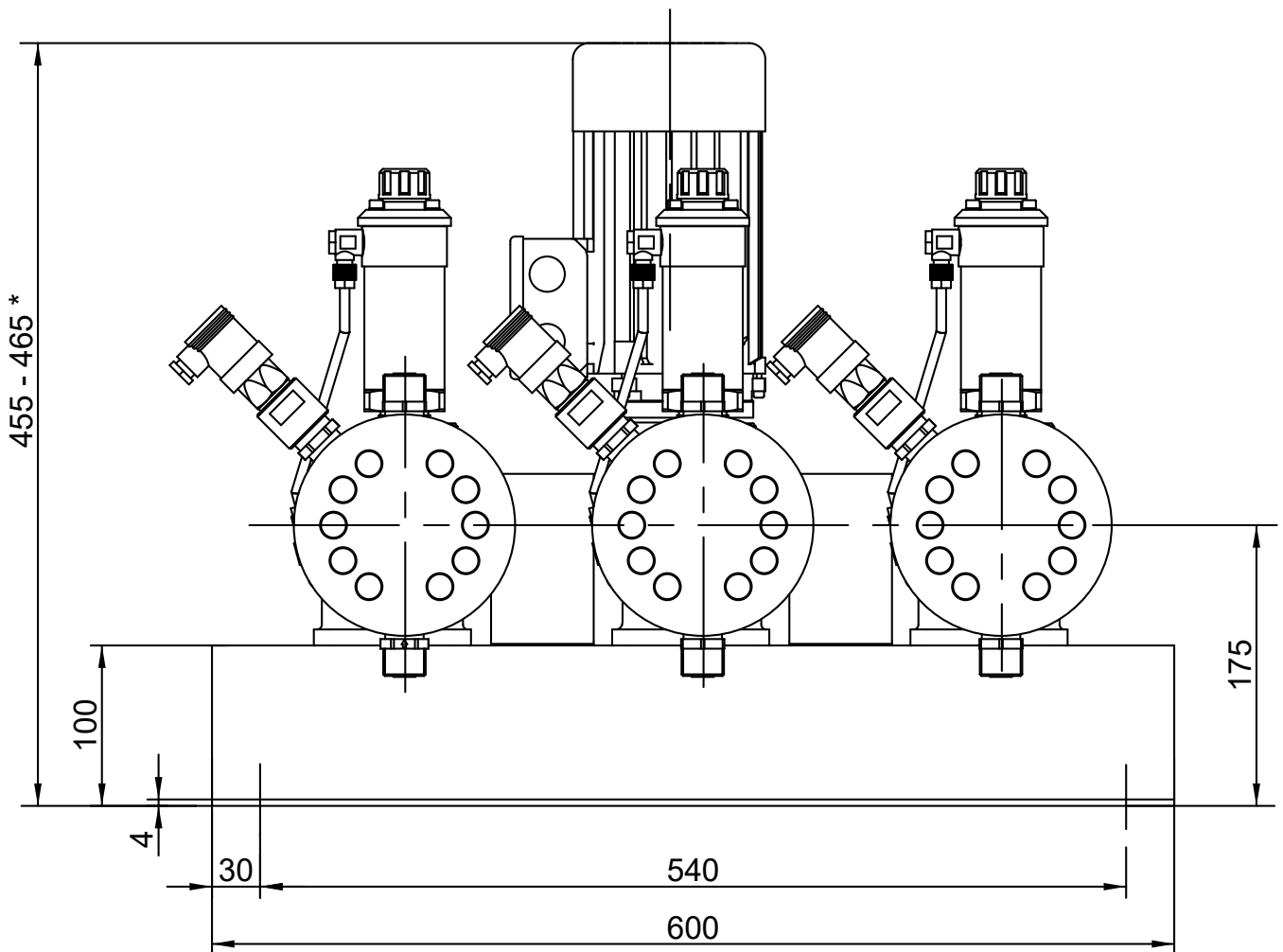
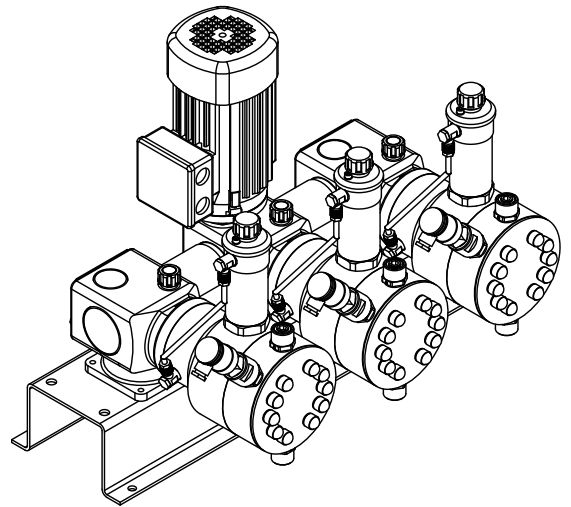

* at 409.2-1,6e to -25e: 455 mm
at 409.2-50e to -350e: 465 mm

DosingPump.ir

DIMENSIONS (EXAMPLE)

3-fold combination pump R(F) 410.2 / RK 410.2 / RK 409.2

Due to the many possibilities, this dimensional drawing is only to be considered as an example. In the individual case of application, a detailed dimensional drawing with all necessary dimensions will be prepared.

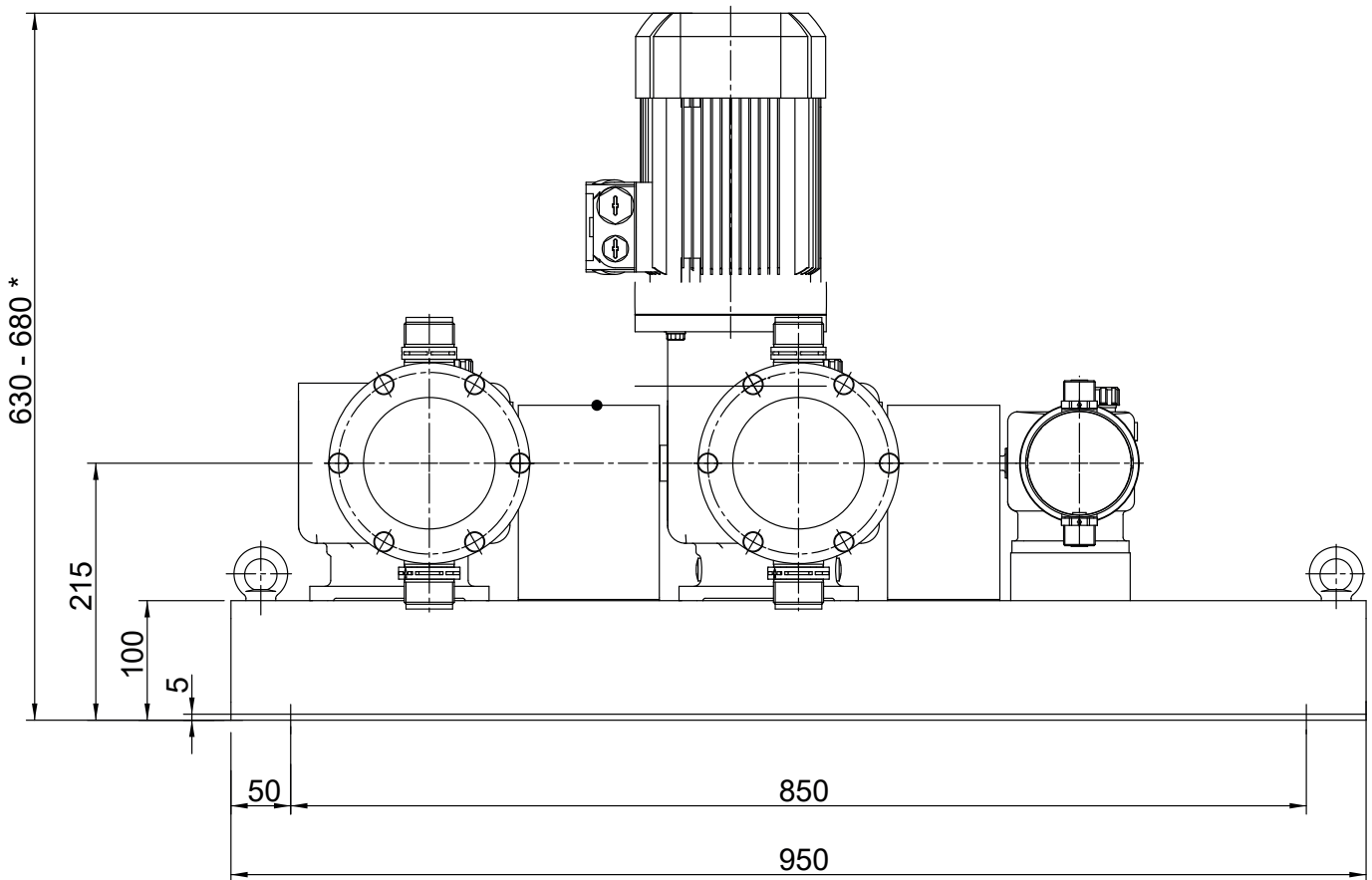
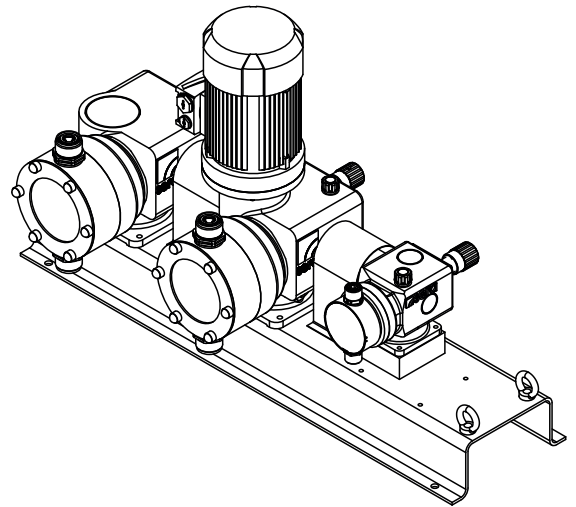

- * at 410.2-280e/-570e: 630 mm
- at 410.2-900e: 640 mm
- at 410.2-1450e: 680 mm

DosingPump.ir

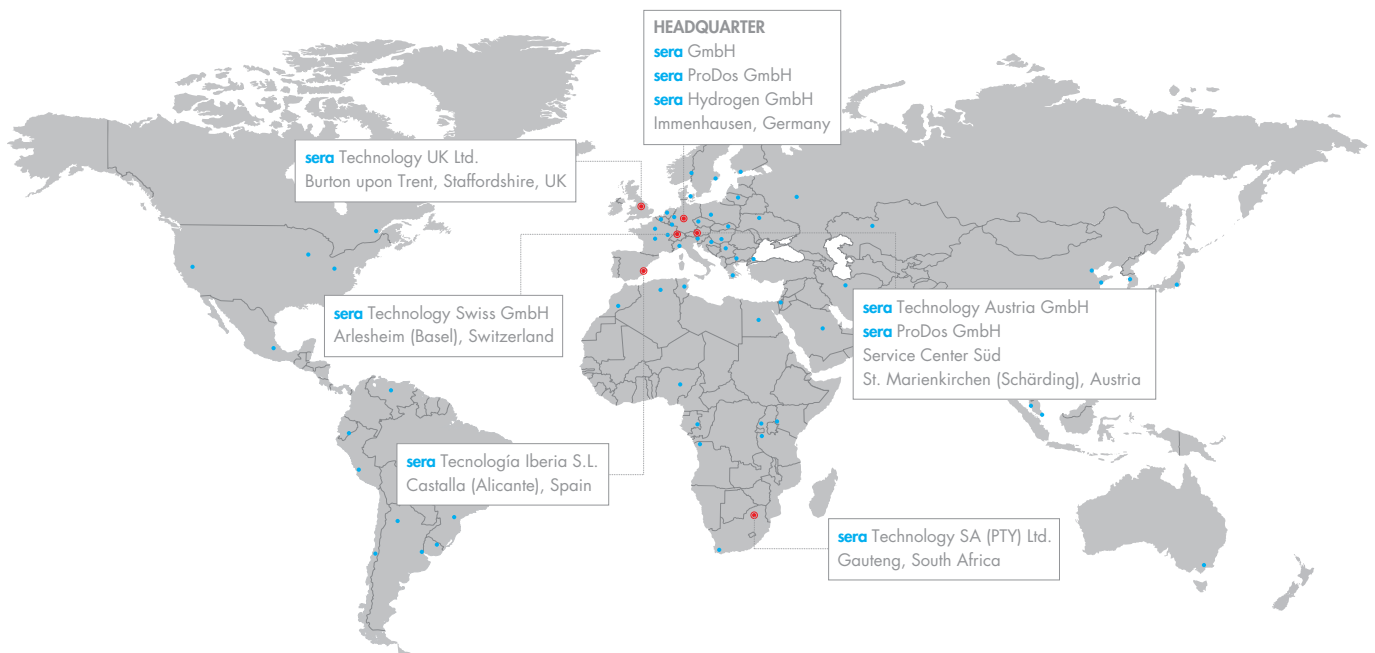

WORKING FOR YOU ALL OVER THE WORLD

sera GmbH
 sera-Straße 1
 34376 Immenhausen
 Germany

Tel.: +49 5673 999-02
 Fax: +49 5673 999-03

info@sera-web.com
www.sera-web.com

sera ProDos GmbH
 sera-Straße 1
 34376 Immenhausen
 Germany

Tel.: +49 5673 999-02
 Fax: +49 5673 999-03

sales.prodos@sera-web.com
www.sera-web.com

sera Hydrogen GmbH
 sera-Straße 1
 34376 Immenhausen
 Germany

Tel.: +49 5673 999-04
 Fax: +49 5673 999-05

sales.hydrogen@sera-web.com
www.sera-web.com

sera ProDos GmbH Service Center Süd
 Gewerbestraße 5
 4774 St. Marienkirchen (Schärding)
 Austria

Tel.: +49 5673 999-02
 Fax: +49 5673 999-03

sales.prodos@sera-web.com
www.sera-web.com

sera Technology Austria GmbH
 Gewerbestraße 5
 4774 St. Marienkirchen (Schärding)
 Austria

Tel.: +43 7711 31777-0
 Fax: +43 7711 31777-20

sales.at@sera-web.com
www.sera-web.com

sera Technology Swiss GmbH
 Altenmatteweg 5
 4144 Arlesheim
 Switzerland

Tel.: +41 61 51142-60
 Fax: +41 61 51142-61

sales.ch@sera-web.com
www.sera-web.com

sera Technology UK Ltd.
 Unit 5, Granary Wharf Business Park
 Wetmore Road, Burton upon Trent
 Staffordshire DE14 1DU
 United Kingdom

Tel.: +44 1283 753400
 Fax: +44 1283 753401

sales.uk@sera-web.com
www.sera-web.com

sera Technology SA (PTY) Ltd.
 Unit 3-4, Airborne Park
 Cnr Empire & Taljaard Str Bartletts
 Boksburg, 1459 Gauteng
 South Africa

Tel.: +27 11 397 5120
 Fax: +27 11 397 5502

sales.za@sera-web.com
www.sera-web.com

sera Tecnología Iberia S.L.
 Calle Cocentaina n°8,
 03420 Castalla
 (Alicante)
 Spain

Tel: +34 666024 388

sales.es@sera-web.com
www.sera-web.com

www.sera-web.com

DosingPump.ir 